

FAIRMONT CITY COUNCIL AGENDA

Monday, June 26, 2023, 5:30 p.m.

1. **Roll Call/Determination of Quorum**
2. **Pledge of Allegiance**
3. **Approval of Agenda**
4. **Recognition/Presentations**
 - 4.1 Quarterly Employee Years of Service Recognition (03)
 - 4.2 Introduction and Swearing in of New Officers. Introduction of New CSO-Cadet (04)
 - 4.3 Presentation of 2022 Annual Comprehensive Financial Report (05)
5. **Mayor's Update** (39)
6. **Public Discussion/Comment** (Individual comments are limited to 3 minutes) (40)
7. **Consent Agenda** (Items removed from consent will be placed at the end of the items under new business)
 - A. **Minutes**
 - 7.A.1 Regular Meeting, June 12, 2023 (41)
 - B. **Check Registers**
 - 7.B.1 June Accounts Payable (45)
 - C. **Other**
 - 7.C.1 Event Permit – Cardinal Fastpitch Softball Tournament, July 8 & 9, 2023 (46)
 - 7.C.2 Event Permit – Latin Festival, July 29, 2023 (49)
 - 7.C.3 On Sale Liquor License for Bean Town, LLC, d/b/a Bean Town Grill (52)
 - 7.C.4 Temporary On-Sale Liquor License for Forever Emmalyne (53)

- 8. Public Hearings**
- 9. Old Business**
- 10. New Business**
 - 10.1** 2023 Preparing for Emerald Ash Borer, Minnesota DNR Grant Agreement (55)
 - 10.2** Repairs to Gomsrud Channel Wall (70)
 - 10.3** Preliminary and Final Plat for Fairmont Industrial Park Twelfth Addition (79)
 - 10.4** Planned Unit Development for Shop Condominiums at Lot 1, Block 1, Fairmont Industrial Park Twelfth Addition (91)
- 11. Council Discussion**
 - 11.1** City Administrator, Interim City Administrator Search Update (135)
- 12. Staff/Liaison Reports**
 - A. Public Works**
 - B. Finance**
 - C. City Administrator**
 - D. Mayor/Council**
 - Hasek – PUC
 - Kawecki – Library, Community Center Advisory Board
 - Lubenow – Park Board
 - Maynard – Airport, Community Center Advisory Board
- 13. Adjournment**



Fairmont City Council
June 26, 2023

Agenda Item: 4.1

From: Cathy Reynolds, City Administrator
To: Mayor and City Council

Subject: Quarterly Employee Years of Service Recognition

Policy/Action Requested: Recognition of employees for years of service.

Vote Required: ___ Simple Majority ___ Roll Call

Recommendation:

Overview: The City would like to recognize the following employees for their years of service:

- Ben Austin, Street Department – 10 years
- Neal Becker, Water Department – 35 years
- Jaime Bless, Police Department – 20 years
- Eric Schaefer, Park Department – 25 years

Budget Impact: N/A

Attachments:

Council Action: _____ Date: _____



Fairmont City Council
June 26, 2023

Agenda Item: 4.2

From: Chief Hunter
To: Mayor and City Council

Subject: Introduction and swearing in of new officers. Introduction of new CSO-Cadet.

Policy/Action Requested: None
Vote Required: ___ Simple Majority ___ Roll Call

Recommendation: None

Overview:

The Fairmont Police Department has recently added three new patrol officers to their staff. The department would like to have the new officers ceremonially sworn in and have them introduce themselves to the Council and the Community.

The new officers are:

- Officer Justin Jobe
- Officer Theodore Cromwell
- Officer Jordan Slater

The Fairmont Police Department also added a new position in May of 2023, the Community Service Officer-Cadet. This position is designed to provide current law enforcement students the paid opportunity to gain experience on their path to becoming a police officer while they serve their community. By making an investment in a law enforcement student from the area, we hope to proactively address some of the recruitment issues we are currently seeing in the profession. The CSO-Cadet will be assisting our current CSO with a focus on ordinance enforcement and compliance, animal control, parking enforcement, and general community service.

Our new CSO-Cadet is Derek Hughes from Sherburn.

Budget Impact: Positions are within current budget.

Attachments:

Council Action: _____ Date: _____



Fairmont City Council
June 26, 2023

Agenda Item: 4.3

From: Paul Hoyer, Finance Director
To: Mayor and City Council

Subject: Presentation of 2022 Annual Comprehensive Financial Report

Policy/Action Requested: To accept the 2022 audit and approve the distribution of the 2022 Annual Comprehensive Financial Report

Vote Required: Simple Majority Roll Call

Recommendation: Approval

Overview: A representative from Bergan KDV will attend the Council meeting to present the results of the 2022 financial audit.

Budget Impact:

Attachments: 2022 Annual Comprehensive Financial Report
Report on Internal Control and Legal Compliance
Communication Letter

***Note: the 2022 Annual Comprehensive Financial Report has been posted on the City of Fairmont’s website separately.**

Council Action: _____ Date: _____

**City of Fairmont
Martin County, Minnesota**

**Report on Internal Control and Compliance with
Government Auditing Standards and
Legal Compliance**

December 31, 2022

**City of Fairmont
Table of Contents**

Report on Internal Control over Financial Reporting and on Compliance and Other Matters Based on an Audit of Financial Statements Performed in Accordance with <i>Government Auditing Standards</i>	1
Minnesota Legal Compliance	3
Schedule of Findings and Responses on Internal Control	4

**Report on Internal Control over Financial Reporting
and on Compliance and Other Matters Based on an
Audit of Financial Statements Performed in Accordance
with *Government Auditing Standards***

Independent Auditor's Report

Honorable Mayor and Members
of the City Council
City of Fairmont
Fairmont, Minnesota

We have audited, in accordance with the auditing standards generally accepted in the United States of America and the standards applicable to financial audits contained in *Government Auditing Standards* issued by the Comptroller General of the United States, the financial statements of the governmental activities, the business-type activities, the discretely presented component unit, each major fund, and the aggregate remaining fund information of the City of Fairmont, Minnesota, as of and for the year ended December 31, 2022, and the related notes to basic financial statements, which collectively comprise the City's basic financial statements and have issued our report thereon dated June 2, 2023.

Report on Internal Control over Financial Reporting

In planning and performing our audit of the financial statements, we considered the City's internal control over financial reporting (internal control) as a basis for designing audit procedures that are appropriate in the circumstances for the purpose of expressing our opinions on the financial statements, but not for the purpose of expressing an opinion on the effectiveness of the City's internal control. Accordingly, we do not express an opinion on the effectiveness of the City's internal control.

A deficiency in internal control exists when the design or operation of a control does not allow management or employees, in the normal course of performing their assigned functions, to prevent, or detect and correct, misstatements on a timely basis. A material weakness is a deficiency, or a combination of deficiencies, in internal control such that there is a reasonable possibility that a material misstatement of the City's financial statements will not be prevented, or detected and corrected, on a timely basis. A significant deficiency is a deficiency, or a combination of deficiencies, in internal control that is less severe than a material weakness, yet important enough to merit attention by those charged with governance.

Our consideration of internal control was for the limited purpose described in the preceding paragraph and was not designed to identify all deficiencies in internal control that might be material weaknesses or significant deficiencies and therefore, material weaknesses or significant deficiencies may exist that were not identified. However, as described in the accompanying Schedule of Findings and Responses on Internal Control, we identified certain deficiencies in internal control that we consider to be a material weakness identified as Audit Finding 2022-001.

**City of Fairmont
Martin County, Minnesota**

Communications Letter

December 31, 2022

**City of Fairmont
Table of Contents**

Report on Matters Identified as a Result of the Audit of the Basic Financial Statements	1
Material Weakness	3
Required Communication	4
Financial Analysis	9
Emerging Issues	21

**Report on Matters Identified as a Result of
the Audit of the Basic Financial Statements**

Honorable Mayor, Members
of the City Council and Management
City of Fairmont
Fairmont, Minnesota

In planning and performing our audit of the basic financial statements of the governmental activities, business-type activities, the discretely presented component unit, each major fund, and the aggregate remaining fund information of the City of Fairmont, as of and for the year ended December 31, 2022, in accordance with auditing standards generally accepted in the United States of America and the standards applicable to financial audits contained in *Government Auditing Standards*, issued by the Comptroller General of the United States, we considered the City's internal control over financial reporting (internal control) as a basis for designing audit procedures that are appropriate in the circumstances for the purpose of expressing our opinions on the financial statements, but not for the purpose of expressing an opinion on the effectiveness of the City's internal control. Accordingly, we do not express an opinion on the effectiveness of the City's internal control over financial reporting.

Our consideration of internal control was for the limited purpose described in the preceding paragraph and was not designed to identify all deficiencies in internal control that might be material weaknesses or significant deficiencies and, therefore, material weaknesses or significant deficiencies may exist that have not been identified. In addition, because of inherent limitations in internal control, including the possibility of management override of controls, misstatements due to error, or fraud may occur and not be detected by such controls. However, as discussed below, we identified certain deficiencies in internal control that we consider to be a material weakness.

A deficiency in internal control exists when the design or operation of a control does not allow management or employees, in the normal course of performing their assigned functions, to prevent, or detect and correct, misstatements on a timely basis. A material weakness is a deficiency, or a combination of deficiencies, in internal control over financial reporting, such that there is a reasonable possibility that a material misstatement of the City's basic financial statements will not be prevented, or detected and corrected, on a timely basis. A reasonable possibility exists when the likelihood of an event occurring is either reasonably possible or probable as defined as follows:

- *Reasonably possible.* The chance of the future event or events occurring is more than remote but less than likely.
- *Probable.* The future event or events are likely to occur.

The material weakness identified is stated within this letter.

A significant deficiency is a deficiency, or a combination of deficiencies, in internal control that is less severe than a material weakness, yet important enough to merit attention by those charged with governance.

The accompanying memorandum also includes financial analysis provided as a basis for discussion. The matters discussed herein were considered by us during our audit and they do not modify the opinion expressed in our Independent Auditor's Report dated June 2, 2023, on such statements.

This communication, which is an integral part of our audit, is intended solely for the information and use of the City Council, management, others within the City, and state oversight agencies and is not intended to be, and should not be, used by anyone other than these specified parties.

BergankDV, Ltd.

St. Cloud, Minnesota
June 2, 2023

City of Fairmont
Material Weakness

Material Audit Adjustment

We proposed an audit adjustment that we considered, both individually and in the aggregate, to be quantitatively material to the financial statements. This condition could adversely affect the City's ability to present financial statements free of material misstatements. The following area needed adjustment: accrued payroll.

City of Fairmont Required Communication

We have audited the basic financial statements of the governmental activities, business-type activities, the aggregate discretely presented component unit, each major fund, and the aggregate remaining fund information of the City as of and for the year ended December 31, 2022. Professional standards require that we advise you of the following matters related to our audit.

Our Responsibility in Relation to the Financial Statement Audit

As communicated in our engagement letter, our responsibility, as described by professional standards, is to form and express opinions about whether the basic financial statements prepared by management with your oversight are presented fairly, in all material respects, in accordance with accounting principles generally accepted in the United States of America. Our audit of the basic financial statements does not relieve you or management of its respective responsibilities.

Our responsibility, as prescribed by professional standards, is to plan and perform our audit to obtain reasonable, rather than absolute, assurance about whether the basic financial statements are free of material misstatement. An audit of the basic financial statements includes consideration of internal control over financial reporting as a basis for designing audit procedures that are appropriate in the circumstances, but not for the purpose of expressing an opinion on the effectiveness of the City's internal control over financial reporting. Accordingly, as part of our audit, we considered the internal control of the City solely for the purpose of determining our audit procedures and not to provide any assurance concerning such internal control.

We are also responsible for communicating significant matters related to the audit that are, in our professional judgement, relevant to your responsibilities in overseeing the financial reporting process. However, we are not required to design procedures for the purpose of identifying other matters to communicate to you.

Generally accepted accounting principles provide for certain Required Supplementary Information (RSI) to supplement the basic financial statements. Our responsibility with respect to the RSI, which supplements the basic financial statements, is to apply certain limited procedures in accordance with generally accepted auditing standards. However, the RSI was not audited and, because the limited procedures do not provide us with sufficient evidence to express an opinion or provide any assurance, we do not express an opinion or provide any assurance on the RSI.

Our responsibility for the supplementary information accompanying the basic financial statements, as described by professional standards, is to evaluate the presentation of the supplementary information in relation to the basic financial statements as a whole and to report on whether the supplementary information is fairly stated, in all material respects, in relation to the basic financial statements as a whole.

Our responsibility with respect to the other information in documents containing the audited basic financial statements and auditor's report does not extend beyond the basic financial information identified in the report. We have no responsibility for determining whether this other information is properly stated. This other information was not audited, and we do not express an opinion or provide any assurance on it.

City of Fairmont Required Communication

Our Responsibility in Relation to *Government Auditing Standards*

As communicated in our engagement letter, part of obtaining reasonable assurance about whether the basic financial statements are free of material misstatement, we performed tests of the City's compliance with certain provisions of laws, regulations, contracts, and grant agreements, noncompliance with which could have a direct and material effect on the determination of basic financial statement amounts. However, the objective of our tests was not to provide an opinion on compliance with such provisions.

Planned Scope and Timing of the Audit

We conducted our audit consistent with the planned scope and timing we previously communicated to you.

Compliance with All Ethics Requirements Regarding Independence

The engagement team, others in our firm, as appropriate, our firm, and our network firms have complied with all relevant ethical requirements regarding independence.

Significant Risks Identified

We have identified the following significant risks of material misstatement:

- Risk of Improper Revenue Recognition – Revenue recognition is considered a fraud risk on substantially all engagements as it is generally the largest line item impacting a City's change in fund balance or net position.
- Risk of Misappropriation of Assets – Misappropriation of assets is considered a risk in substantially all engagements as assets may be misappropriated due to fraud or error.
- Risk of Management Override of Controls – Management override of internal control is considered a risk in substantially all engagements as management may be incentivized to produce better results.

Qualitative Aspects of the City's Significant Accounting Practices

Significant Accounting Policies

Management has the responsibility to select and use appropriate accounting policies. A summary of the significant accounting policies adopted by the City is included in the notes to basic financial statements. There have been no initial selection of accounting policies and no changes to significant accounting policies or their application during 2022. No matters have come to our attention that would require us, under professional standards, to inform you about (1) the methods used to account for significant unusual transactions and (2) the effect of significant accounting policies in controversial or emerging areas for which there is a lack of authoritative guidance or consensus.

Significant Accounting Estimates

Accounting estimates are an integral part of the basic financial statements prepared by management and are based on management's current judgements. Those judgements are normally based on knowledge and experience about past and current events and assumptions about future events. Certain accounting estimates are particularly sensitive because of their significance to the basic financial statements and because of the possibility that future events affecting them may differ markedly from management's current judgements. The most sensitive estimates affecting the basic financial statements relate to:

City of Fairmont Required Communication

Qualitative Aspects of the City's Significant Accounting Practices (Continued)

Significant Accounting Estimates (Continued)

Depreciation – The City is currently depreciating its capital assets over their estimated useful lives, as determined by management, using the straight-line method.

Total Other Post Employment Benefits (OPEB) Liability, Deferred Outflows of Resources Related to OPEB and Deferred Inflows of Resources Related to OPEB – These balances are based on an actuarial study using the estimates of future obligations of the City for post employment benefits.

Net Pension Liability, Deferred Outflows of Resources Relating to Pensions and Deferred Inflows of Resources Relating to Pensions – These balances are based on an allocation by the pension plans using estimates based on contributions.

We evaluated the key factors and assumptions used to develop the accounting estimates and determined that they are reasonable in relation to the basic financial statements taken as a whole and in relation to the applicable opinion units.

Financial Statement Disclosures

Certain basic financial statement disclosures involve significant judgment and are particularly sensitive because of their significance to financial statement users. The basic financial statement disclosures are neutral, consistent, and clear.

Significant Difficulties Encountered during the Audit

We encountered no significant difficulties in dealing with management relating to the performance of the audit.

Uncorrected and Corrected Misstatements

For the purposes of this communication, professional standards require us to accumulate all known and likely misstatements identified during the audit, other than those that we believe are trivial, and communicate them to the appropriate level of management. Further, professional standards require us to also communicate the effects of uncorrected misstatements related to prior periods on the relevant classes of transactions, account balances or disclosures, and the basic financial statements taken as a whole and each applicable opinion unit. Management did not identify, and we did not notify them of any uncorrected financial statement misstatements.

In addition, professional standards require us to communicate to you all material, corrected misstatements that were brought to the attention of management as a result of our audit procedures. The following material misstatement that we identified as a result of our audit procedures was brought to the attention of and corrected by management.

- Accrued Payroll was understated

City of Fairmont Required Communication

Disagreements with Management

For purposes of this letter, professional standards define a disagreement with management as a matter, whether or not resolved to our satisfaction, concerning a financial accounting, reporting, or auditing matter, which could be significant to the City's basic financial statements or the auditor's report. No such disagreements arose during the course of our audit.

Representations Requested from Management

We have requested certain written representations from management, which are included in the management representation letter.

Management's Consultations with Other Accountants

In some cases, management may decide to consult with other accountants about auditing and accounting matters. Management has informed us that, and to our knowledge, there were no consultations with other accountants regarding auditing and accounting matters.

Other Significant Matters, Findings, or Issues

In the normal course of our professional association with the City, we generally discuss a variety of matters, including the application of accounting principles and auditing standards, significant events or transactions that occurred during the year, operating and regulatory conditions affecting the City, and operational plans and strategies that may affect the risks of material misstatement. None of the matters discussed resulted in a condition to our retention as the City's auditor.

Other Information Included in Annual Reports

Pursuant to professional standards, our responsibility as auditors for other information, whether financial or nonfinancial, included in the City's annual reports, does not extend beyond the information identified in the audit report, and we are not required to perform any procedures to corroborate such other information.

We applied certain limited procedures to the RSI that supplements the basic financial statements. Our procedures consisted of inquiries of management regarding the methods of preparing the information and comparing the information for consistency with management's responses to our inquiries, the basic financial statements, and other knowledge we obtained during our audit of the basic financial statements. We did not audit the RSI and do not express an opinion or provide any assurance on the RSI.

With respect to the supplementary information accompanying the financial statements, we made certain inquiries of management and evaluated the form, content and methods of preparing the information to determine that the information complies with accounting principles generally accepted in the United States of America, the method of preparing it has not changed from the prior period, and the information is appropriate and complete in relation to our audit of the financial statements. We compared and reconciled the supplementary information to the underlying accounting records used to prepare the basic financial statements or to the basic financial statements themselves.

**City of Fairmont
Required Communication**

Other Information Included in Annual Reports (Continued)

We were not engaged to report on the other information accompanying the basic financial statements but are not RSI. Such information has not been subjected to the auditing procedures applied in the audit of the basic financial statements, and accordingly, we do not express an opinion or provide any assurance on it.

Our responsibility also includes communicating to you any information which we believe is a material misstatement of fact. Nothing came to our attention that caused us to believe that such information, or its manner of presentation, is materially inconsistent with the information, or manner of its presentation, appearing in the basic financial statements.

City of Fairmont Financial Analysis

The following pages provide graphic representation of select data pertaining to the financial position and operations of the City for the past five years. Our analysis of each graph is presented to provide a basis for discussion of past performance and how implementing certain changes may enhance future performance. A subsequent discussion of this information should be useful for planning purposes.

General Fund

Total fund balance in the General Fund increased 6.32% in 2022 to \$7,466,493. General Fund revenues and other financing sources exceeded by expenditures and other financing uses by \$443,534 during 2022. A more detailed analysis of the General Fund revenue and expenditure components are presented on the following pages.

The City's fund balance policy establishes an unrestricted fund balance range of 55%-65% of the subsequent year's budgeted expenditures. The current General Fund unrestricted fund balance represents 70.9% of 2022 General Fund budgeted expenditures, or eight and half months of those budgeted expenditures. These percentages are consistent with a Statement of Position issued by the Office of the State Auditor which recommended an unrestricted General Fund balance of between 35% to 50% of budgeted revenues and no less than five months of operating expenditures.

A five year history of General Fund balance is shown below.

General Fund Balance

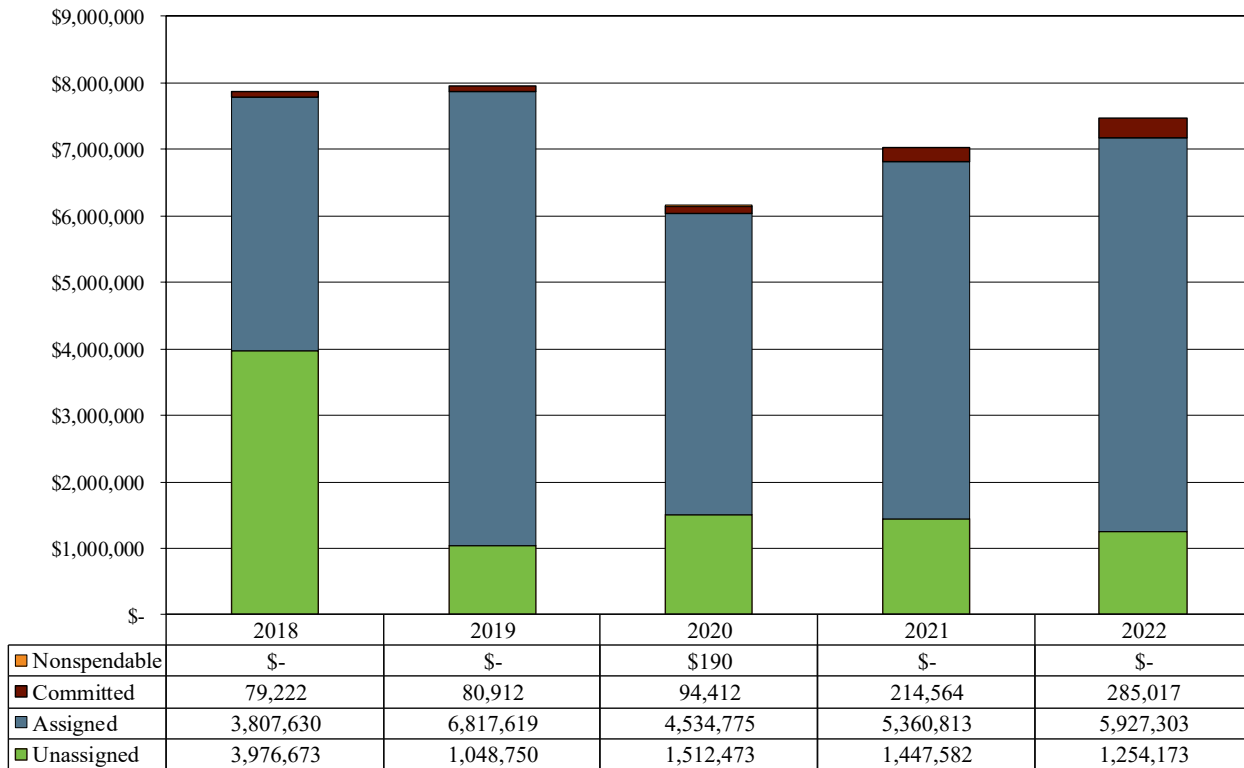

City of Fairmont Financial Analysis

General Fund Revenues

Allocations of the City's revenues by source for the current and preceding year are displayed below. The allocation was relatively consistent from 2021 to 2022.

General Fund Revenues 2022

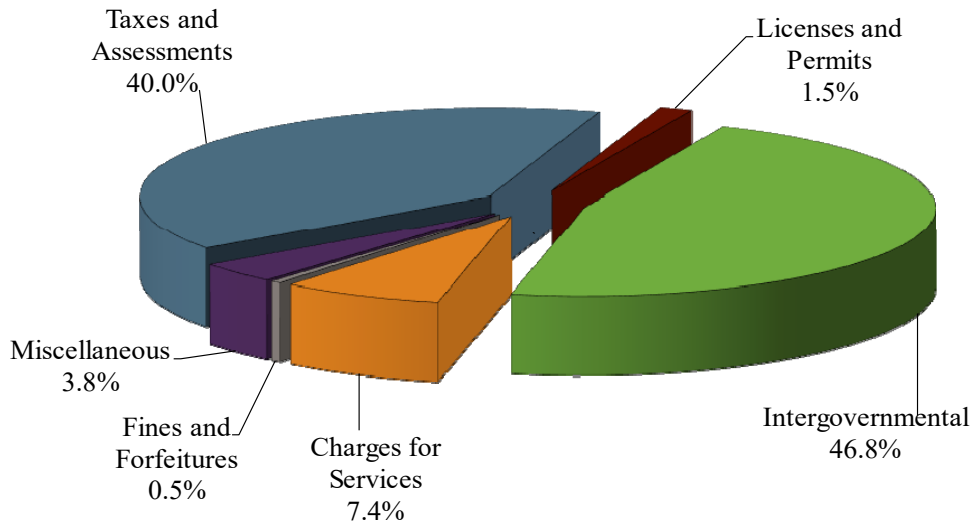

General Fund Revenues 2021

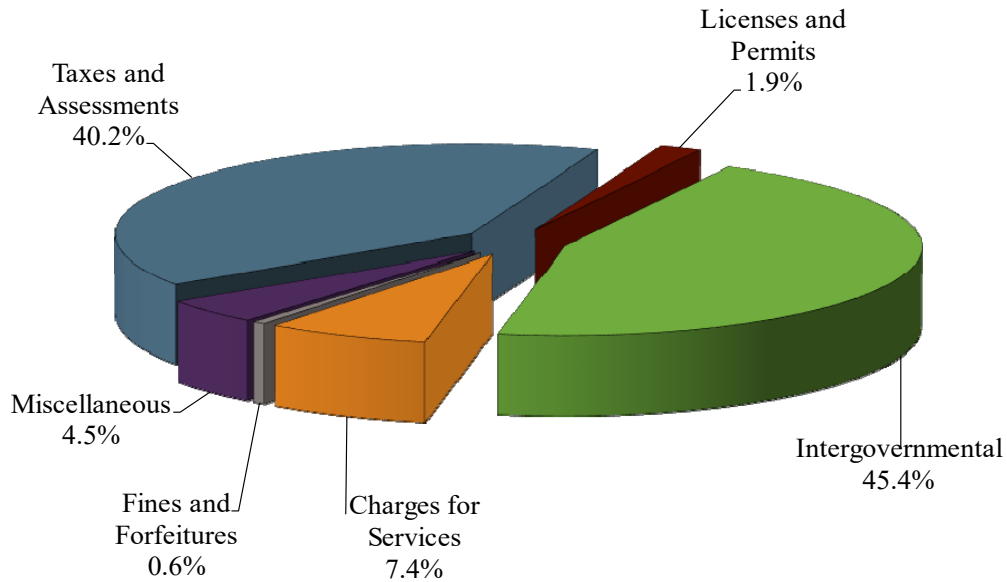

City of Fairmont Financial Analysis

General Fund Revenues (Continued)

The chart below shows the City's revenues by source for the last five years. Property taxes decreased \$146,440 from 2021 to 2022 due to moving the new public works building debt service levy to a debt service fund. Miscellaneous revenues decreased \$88,050 mainly due to a change in fair market value of investments due to the worsening market conditions.

General Fund Revenues

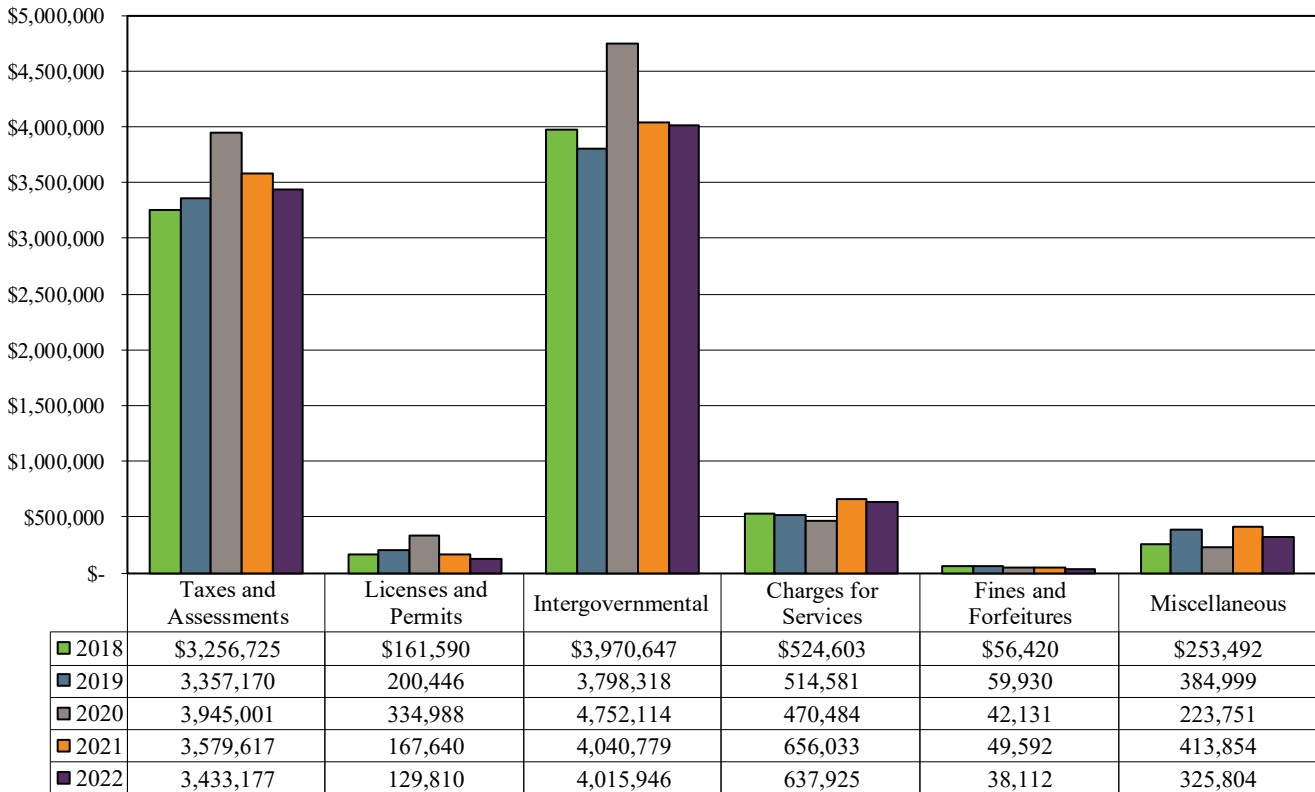

City of Fairmont Financial Analysis

General Fund Expenditures

The pie charts below show the breakdown of expenditures in the General Fund for the last two years. The allocation did not change significantly from 2021 to 2022.

General Fund Expenditures 2022

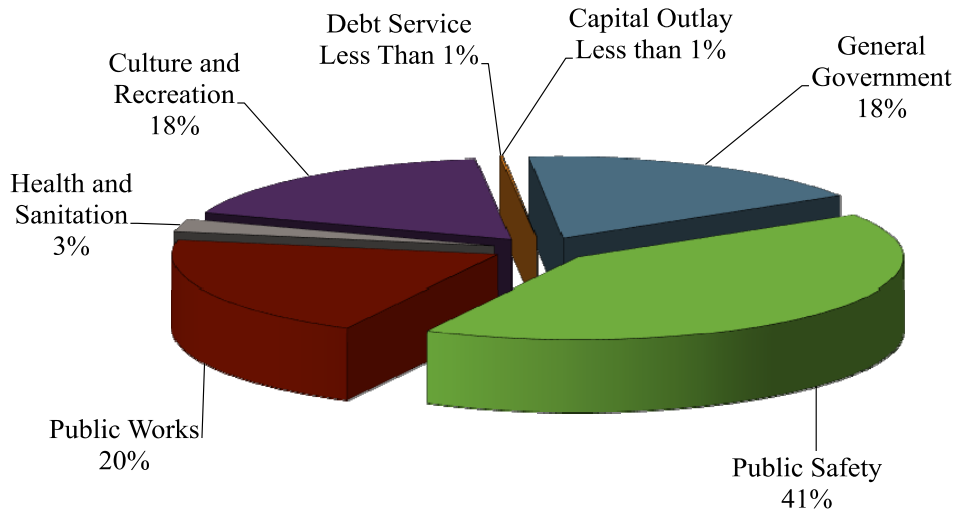

General Fund Expenditures 2021

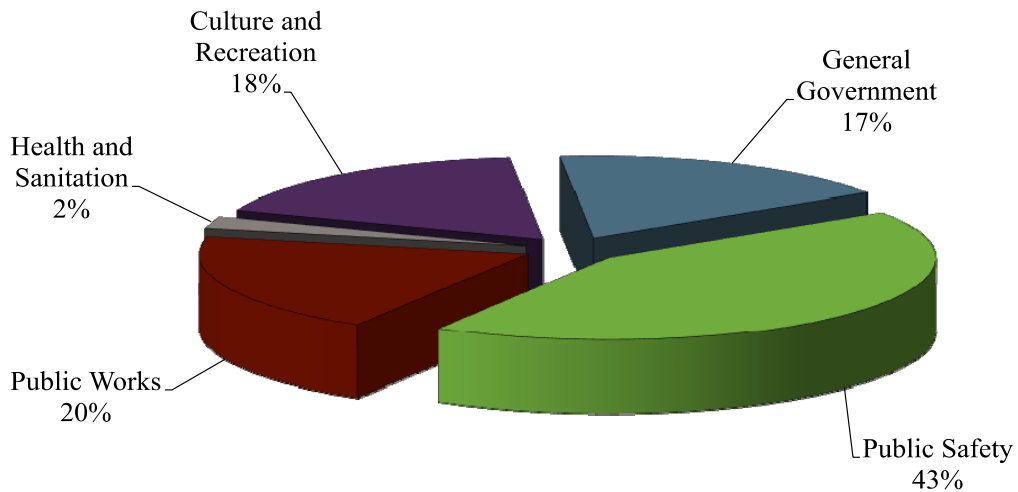

City of Fairmont Financial Analysis

General Fund Expenditures (Continued)

Five year trend information for General Fund expenditures by function is shown below. From 2021 to 2022 expenditures increased \$283,502. General Government increased by \$93,045 due to taking down more dilapidated houses. Culture and recreation increased \$76,441 due to increased hours at the aquatic park. Other functions had minor variances from the prior year.

General Fund Expenditures

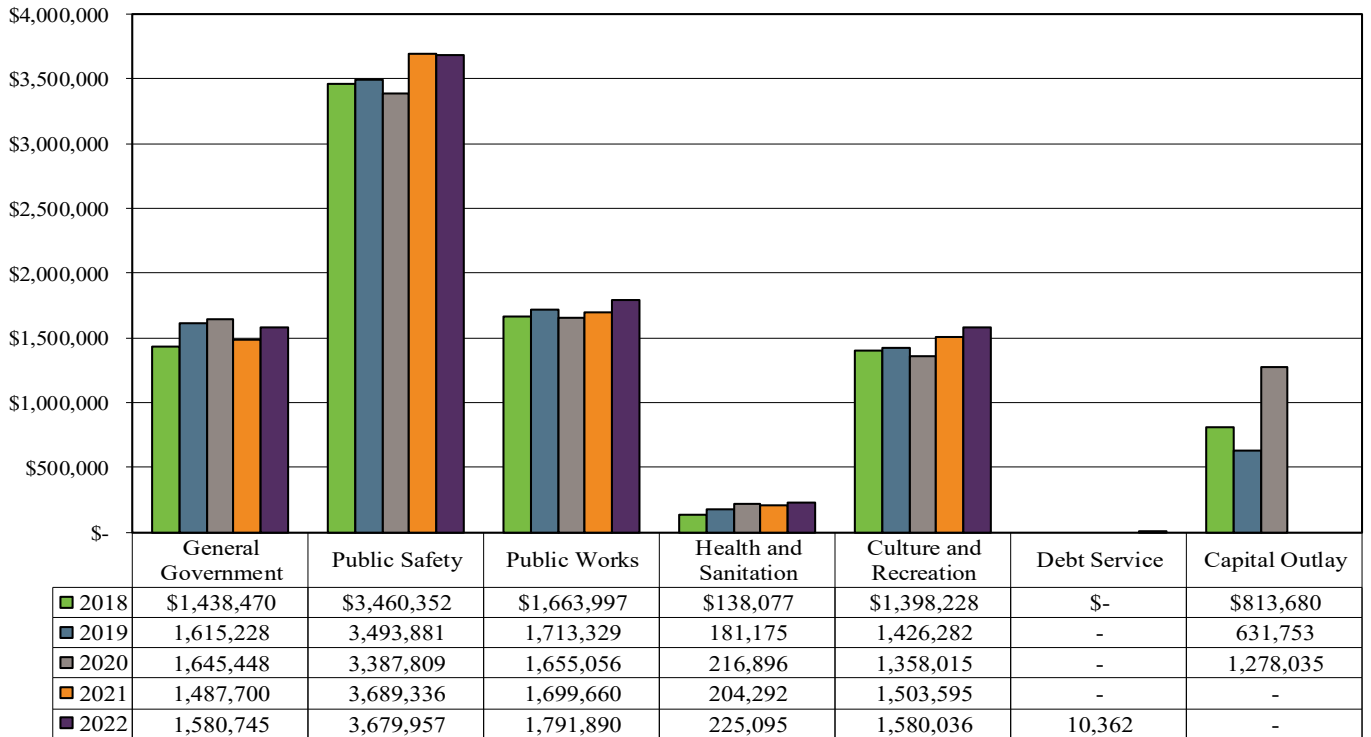

**City of Fairmont
Financial Analysis**

General Fund Budget and Actual

	Budget	Actual Amounts	Over (Under) Budget
Revenues			
Property taxes	\$ 3,492,525	\$ 3,433,177	\$ (59,348)
Licenses and permits	150,800	129,810	(20,990)
Intergovernmental revenues	4,031,001	4,015,946	(15,055)
Charges for services	614,276	637,925	23,649
Fines and forfeitures	48,500	38,112	(10,388)
Miscellaneous	249,000	325,804	76,804
Total revenues	8,586,102	8,580,774	(5,328)
Expenditures			
General government	1,655,186	1,580,745	(74,441)
Public safety	3,890,486	3,679,957	(210,529)
Public works	1,831,348	1,791,890	(39,458)
Health and sanitation	178,871	225,095	46,224
Culture and recreation	1,650,211	1,580,036	(70,175)
Capital outlay	-	-	-
Debt Service	-	10,362	10,362
Total expenditures	9,206,102	8,868,085	(338,017)
Other Financing Sources (Uses)			
Transfers in	825,000	846,046	21,046
Transfers out	(205,000)	(115,201)	89,799
Total other financing sources (uses)	620,000	730,845	110,845
Net change in fund balances	\$ -	\$ 443,534	\$ 443,534

The chart above compares actual revenues and expenditures to amounts budgeted in the General Fund for 2022. Actual General Fund revenues were under budget by \$5,328, or 0.1%. All sources of revenue were relatively consistent with budgeted amounts.

Total actual expenditures were under budgeted expenditures by \$338,017, or 3.7%. Public safety was \$210,529 or 5.4% under budget mostly related to personnel costs. Remaining expenditure categories showed minor budget variations.

City of Fairmont Financial Analysis

Water Fund

Water Fund operating results over the last five years are presented below. Operating revenues have exceeded operating expenses in four out of the five years presented. Operating revenue in the Water Fund increased 11.4% over the prior year as a result of increased usage and rate adjustments. Expenses for the year decreased \$816,555, mostly due to the lime pond project costs from the prior year being larger than the current year costs.

Water Fund

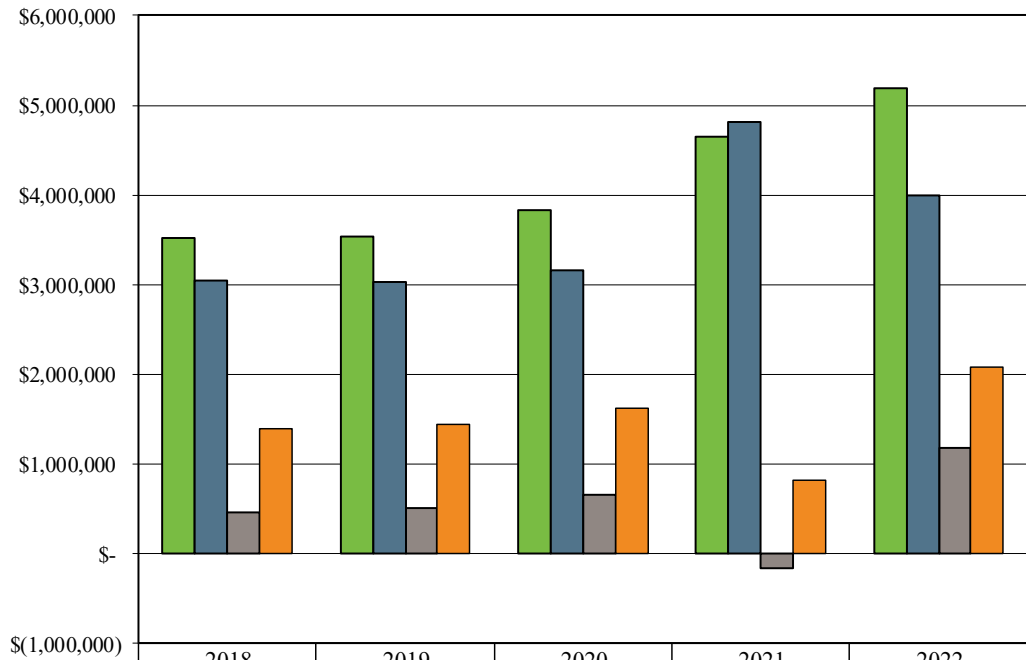

	2018	2019	2020	2021	2022
Total Operating Revenues	\$3,513,185	\$3,538,073	\$3,828,469	\$4,657,030	\$5,187,509
Total Operating Expenses	3,045,939	3,033,190	3,163,819	4,815,058	3,998,503
Operating Income (Loss)	467,246	504,883	664,650	(158,028)	1,189,006
Operating Income without Depreciation	1,399,775	1,448,963	1,629,059	813,803	2,087,277

City of Fairmont Financial Analysis

Sewer Fund

Sewer Fund operating results over the last five years are presented below. Operating revenues have exceeded operating expenses in all five years presented. Operating revenues increased \$689,411, or 26.1% due to rate adjustments and a large insurance claim, and operating expenses increased \$615,845 or 29.3% due to Sewer Plant repairs and digester cleaning.

Sewer Fund

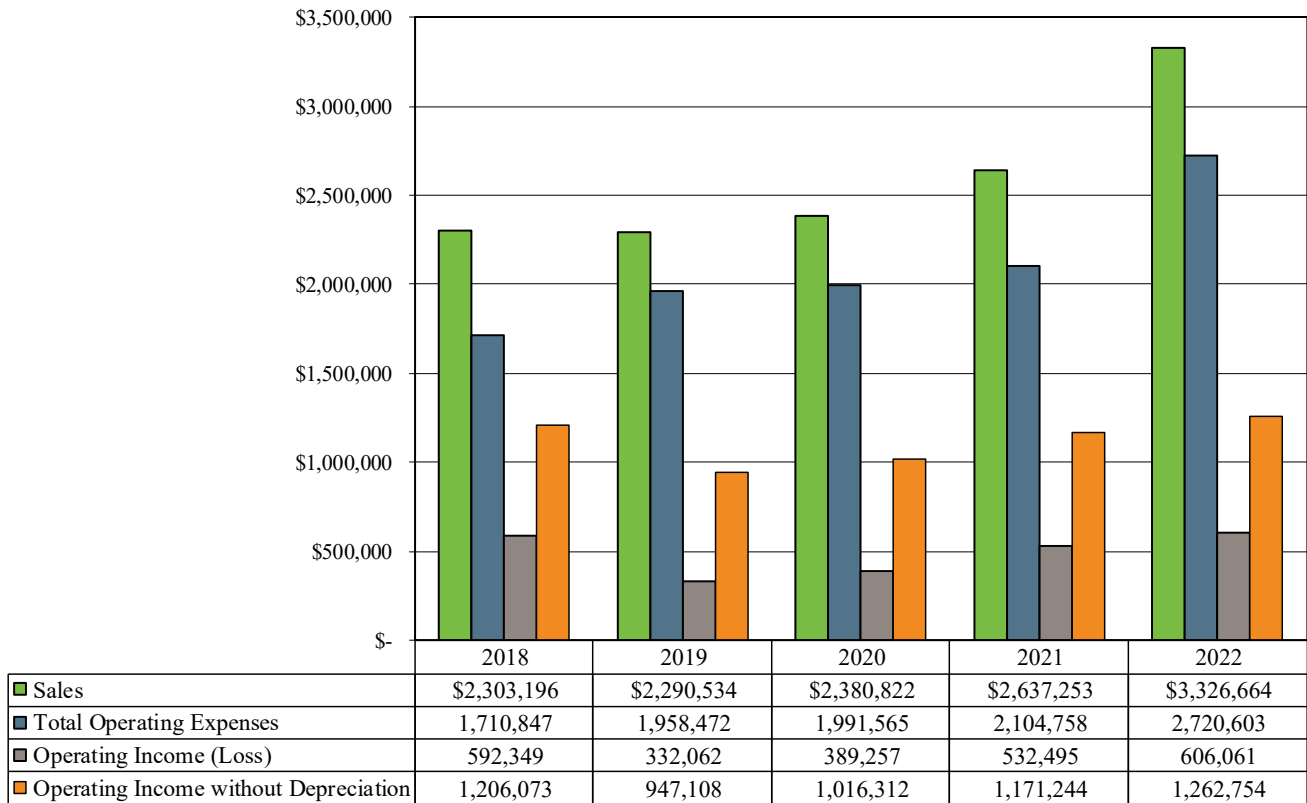

City of Fairmont Financial Analysis

Storm Water Fund

Operating results of the Storm Water Fund are presented below. This Fund has been able to generate operating income with and without depreciation for each of the last five years. From 2021 to 2022, operating revenues of the Fund increased \$318. Operating expenses for the Fund increased \$31,548, or 5.9% due to increased depreciation related to large capital asset additions.

Storm Water Fund

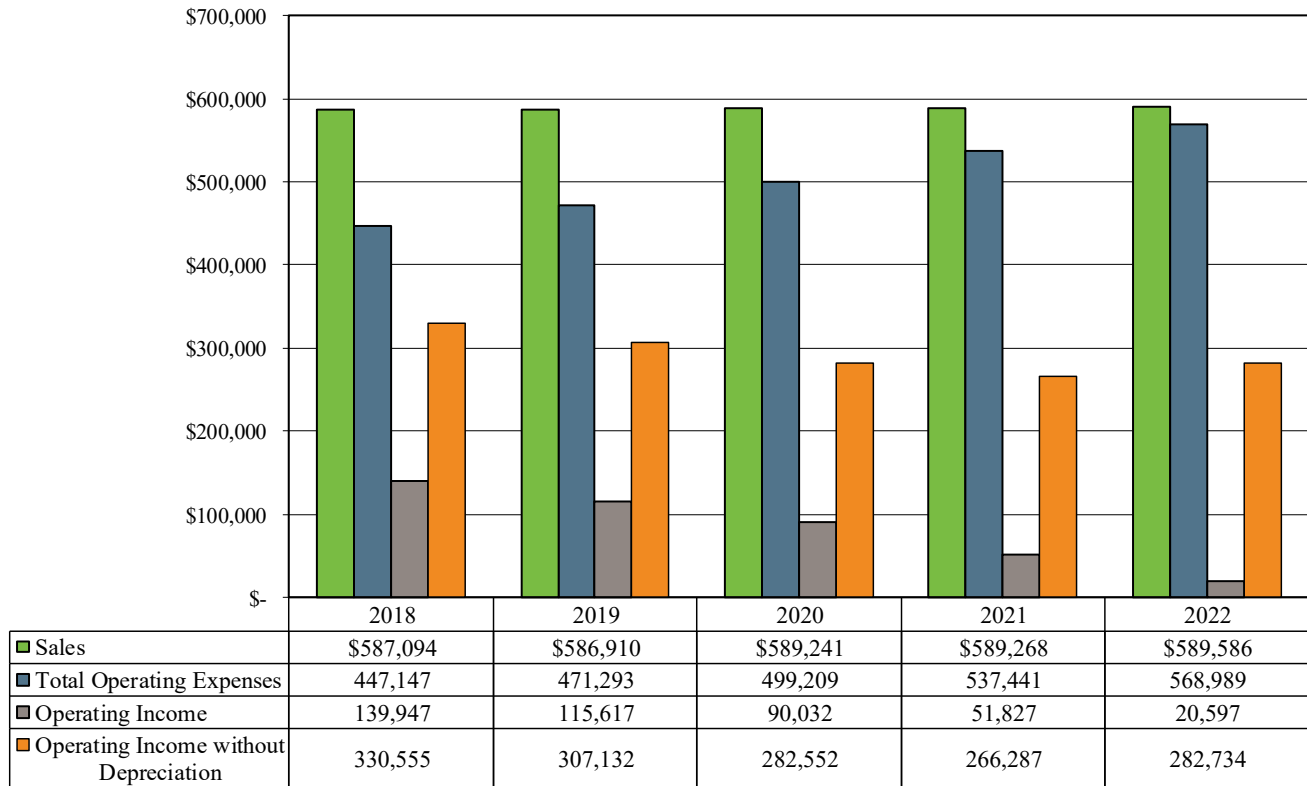

City of Fairmont Financial Analysis

Electric Fund,

Operating results of the Electric Fund are presented below. This Fund has been able to generate operating income with and without depreciation for all of the last five years. From 2021 to 2022, operating revenues of the Fund stayed relatively consistent. Operating expenses for the Fund increased \$444,295, or 3% due to increased purchased power costs related to increased usage.

Electric Fund

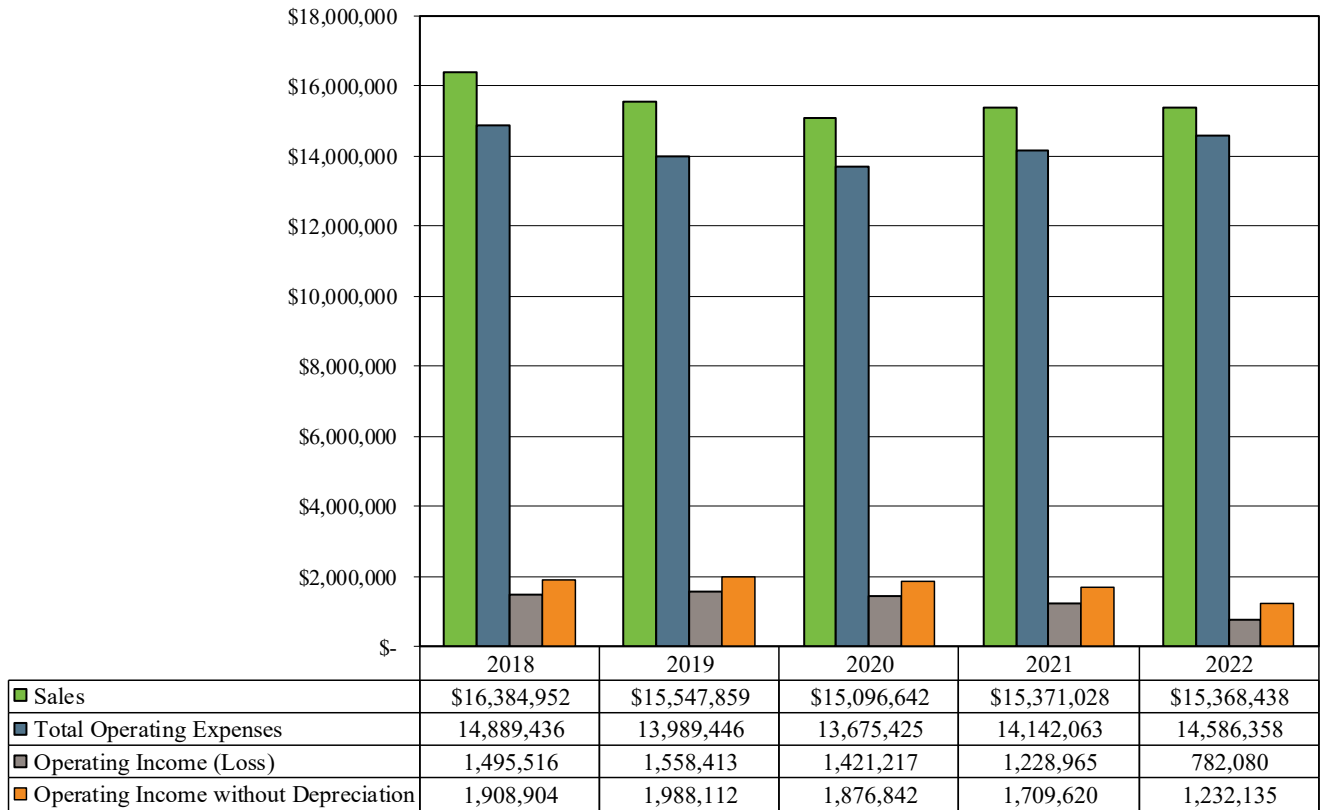

City of Fairmont Financial Analysis

Liquor Fund

Liquor Fund operating trends are illustrated on the graphs below and on the following page. Sales decreased by 0.3%, from \$4,551,173 in 2021 to \$4,539,324 in 2022. Cost of sales had an increase of 0.7%, from \$3,223,150 in 2021 to \$3,245,750 in 2022.

Liquor Fund

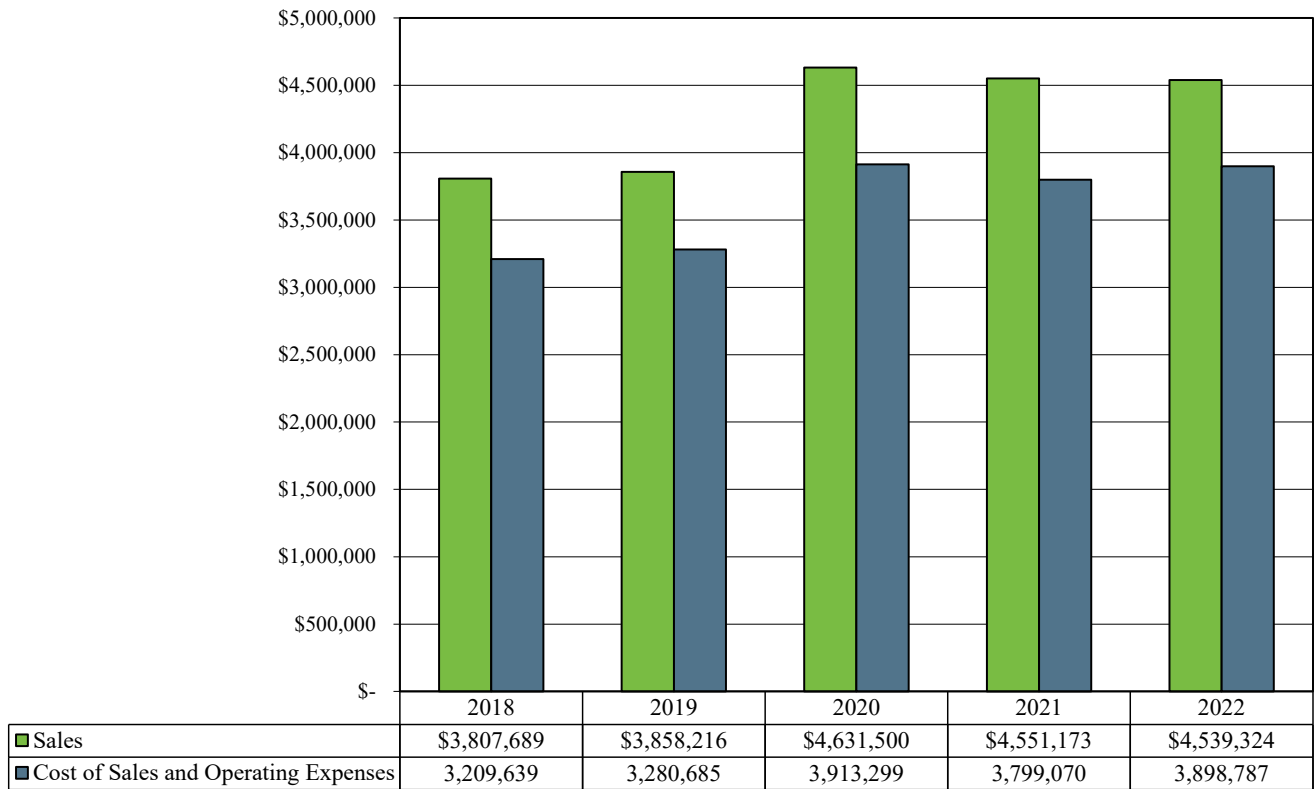

**City of Fairmont
Financial Analysis**

Liquor Fund (Continued)

Gross profit percentage decreased from 29.2% in 2021 to 28.5% in 2022. The Liquor Fund had operating income of \$640,537 in 2022, a decrease from the operating income of \$752,103 in 2021. This was primarily due to increased costs of goods.

Liquor Fund Gross Profit Percentage

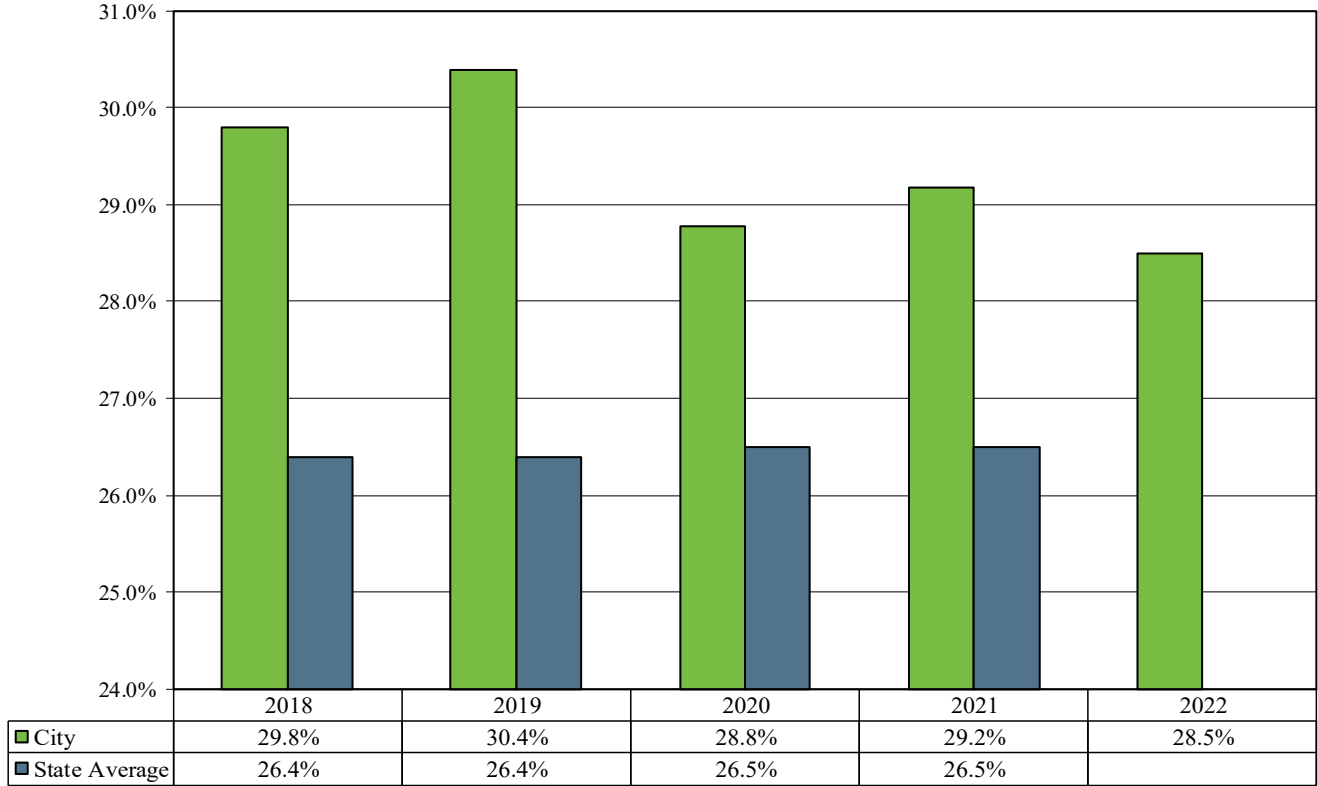

*2022 State Average is not yet available.

City of Fairmont Emerging Issues

Executive Summary

The following is an executive summary of financial related updates to assist you in staying current on emerging issues in accounting and finance. This summary will give you a preview of the new standards that have been recently issued and what is on the horizon for the near future. The most recent and significant updates include:

- **Accounting Standard Update – GASB Statement No. 96 – Subscription-Based Information Technology Arrangements**

GASB has issued GASB Statement No. 96 relating to accounting and financial reporting for subscription-based information technology arrangements. The requirements of this Statement will improve financial reporting by establishing a definition for subscription-based information technology arrangements and providing uniform guidance for accounting and financial reporting for transactions that meet that definition.

- **Accounting Standard Update – GASB Statement No. 100 – Accounting Changes and Error Corrections**

GASB has issued GASB Statement No. 100 relating to accounting and financial reporting for accounting changes and error corrections. The requirements of this Statement will improve the clarity of the accounting and financial reporting requirements for accounting changes and error corrections, which will result in greater consistency in application in practice. In turn, more understandable, reliable, relevant, consistent, and comparable information will be provided to financial statement users for making decisions or assessing accountability.

- **Accounting Standard Update – GASB Statement No. 101 – Compensated Absences**

GASB has issued GASB Statement No. 101 relating to accounting and financial reporting for compensated absences. The unified recognition and measurement model in this Statement will result in a liability for compensated absences that more appropriately reflects when a government incurs an obligation. In addition, the model can be applied consistently to any type of compensated absence and will eliminate potential comparability issues between governments that offer different types of leave.

The following are extensive summaries of the current updates. As your continued business partner, we are committed to keeping you informed of new and emerging issues. We are happy to discuss these issues with you further and their applicability to your City.

Accounting Standard Update – GASB Statement No. 96 – *Subscription-Based Information Technology Arrangements*

This Statement provides guidance on the accounting and financial reporting for subscription-based information technology arrangements (SBITAs) for government end users (governments). This Statement (1) defines a SBITA; (2) establishes that a SBITA results in a right-to-use subscription asset – an intangible asset – and a corresponding subscription liability; (3) provides the capitalization criteria for outlays other than subscription payments, including implementation costs of a SBITA; and (4) requires note disclosures regarding a SBITA. To the extent relevant, the standards for SBITAs are based on the standards established in Statement No. 87, Leases, as amended.

City of Fairmont Emerging Issues

Accounting Standard Update – GASB Statement No. 96 – *Subscription-Based Information Technology Arrangements (Continued)*

A SBITA is defined as a contract that conveys control of the right to use another party's (a SBITA vendor's) information technology (IT) software, alone or in combination with tangible capital assets (the underlying IT assets), as specified in the contract for a period of time in an exchange or exchange-like transaction.

The subscription term includes the period during which a government has a noncancellable right to use the underlying IT assets. The subscription term also includes periods covered by an option to extend (if it is reasonably certain that the government or SBITA vendor will exercise that option) or to terminate (if it is reasonably certain that the government or SBITA vendor will not exercise that option).

Under this Statement, a government generally should recognize a right-to-use subscription asset – an intangible asset – and a corresponding subscription liability. A government should recognize the subscription liability at the commencement of the subscription term, – which is when the subscription asset is placed into service. The subscription liability should be initially measured at the present value of subscription payments expected to be made during the subscription term. Future subscription payments should be discounted using the interest rate the SBITA vendor charges the government, which may be implicit, or the government's incremental borrowing rate if the interest rate is not readily determinable. A government should recognize amortization of the discount on the subscription liability as an outflow of resources (for example, interest expense) in subsequent financial reporting periods.

The subscription asset should be initially measured as the sum of (1) the initial subscription liability amount, (2) payments made to the SBITA vendor before commencement of the subscription term, and (3) capitalizable implementation costs, less any incentives received from the SBITA vendor at or before the commencement of the subscription term. A government should recognize amortization of the subscription asset as an outflow of resources over the subscription term.

Activities associated with a SBITA, other than making subscription payments, should be grouped into the following three stages, and their costs should be accounted for accordingly:

- Preliminary Project Stage, including activities such as evaluating alternatives, determining needed technology, and selecting a SBITA vendor. Outlays in this stage should be expensed as incurred.
- Initial Implementation Stage, including all ancillary charges necessary to place the subscription asset into service. Outlays in this stage generally should be capitalized as an addition to the subscription asset.
- Operation and Additional Implementation Stage, including activities such as subsequent implementation activities, maintenance, and other activities for a government's ongoing operations related to a SBITA. Outlays in this stage should be expensed as incurred unless they meet specific capitalization criteria.

In classifying certain outlays into the appropriate stage, the nature of the activity should be the determining factor. Training costs should be expensed as incurred, regardless of the stage in which they are incurred.

City of Fairmont Emerging Issues

Accounting Standard Update – GASB Statement No. 96 – *Subscription-Based Information Technology Arrangements (Continued)*

If a SBITA contract contains multiple components, a government should account for each component as a separate SBITA or nonsubscription component and allocate the contract price to the different components. If it is not practicable to determine a best estimate for price allocation for some or all components in the contract, a government should account for those components as a single SBITA.

This Statement provides an exception for short-term SBITAs. Short-term SBITAs have a maximum possible term under the SBITA contract of 12 months (or less), including any options to extend, regardless of their probability of being exercised. Subscription payments for short-term SBITAs should be recognized as outflows of resources.

This Statement requires a government to disclose descriptive information about its SBITAs other than short-term SBITAs, such as the amount of the subscription asset, accumulated amortization, other payments not included in the measurement of a subscription liability, principal and interest requirements for the subscription liability, and other essential information.

GASB Statement No. 96 is effective for reporting periods beginning after June 15, 2022. Earlier application is encouraged.

Information provided above was obtained from www.gasb.org.

Accounting Standard Update – GASB Statement No. 100 – *Accounting Changes and Error Corrections – an Amendment of GASB Statement No. 62*

The primary objective of this Statement is to enhance accounting and financial reporting requirements for accounting changes and error corrections to provide more understandable, reliable, relevant, consistent, and comparable information for making decisions or assessing accountability.

This Statement defines accounting changes as changes in accounting principles, changes in accounting estimates, and changes to or within the financial reporting entity and describes the transactions or other events that constitute those changes. As part of those descriptions, for (1) certain changes in accounting principles and (2) certain changes in accounting estimates that result from a change in measurement methodology, a new principle or methodology should be justified on the basis that it is preferable to the principle or methodology used before the change. That preferability should be based on the qualitative characteristics of financial reporting – understandability, reliability, relevance, timeliness, consistency, and comparability. This Statement also addresses corrections of errors in previously issued financial statements.

This Statement prescribes the accounting and financial reporting for (1) each type of accounting change and (2) error corrections. This Statement requires that (a) changes in accounting principles and error corrections be reported retroactively by restating prior periods, (b) changes to or within the financial reporting entity be reported by adjusting beginning balances of the current period, and (c) changes in accounting estimates be reported prospectively by recognizing the change in the current period. The requirements of this Statement for changes in accounting principles apply to the implementation of a new pronouncement in absence of specific transition provisions in the new pronouncement.

City of Fairmont Emerging Issues

Accounting Standard Update – GASB Statement No. 100 – *Accounting Changes and Error Corrections – an Amendment of GASB Statement No. 62 (Continued)*

This Statement also requires that the aggregate amount of adjustments to and restatements of beginning net position, fund balance, or fund net position, as applicable, be displayed by reporting unit in the financial statements.

This Statement requires disclosure in notes to financial statements of descriptive information about accounting changes and error corrections, such as their nature. In addition, information about the quantitative effects on beginning balances of each accounting change and error correction should be disclosed by reporting unit in a tabular format to reconcile beginning balances as previously reported to beginning balances as restated.

Furthermore, this Statement addresses how information that is affected by a change in accounting principle or error correction should be presented in required supplementary information (RSI) and supplementary information (SI). For periods that are earlier than those included in the basic financial statements, information presented in RSI or SI should be restated for error corrections, if practicable, but not for changes in accounting principles.

GASB Statement No. 100 is effective for reporting periods beginning after June 15, 2023. Earlier application is encouraged.

Information provided above was obtained from www.gasb.org.

Accounting Standard Update – GASB Statement No. 101 – *Compensated Absences*

The objective of this Statement is to better meet the information needs of financial statement users by updating the recognition and measurement guidance for compensated absences. That objective is achieved by aligning the recognition and measurement guidance under a unified model and by amending certain previously required disclosures.

This Statement requires that liabilities for compensated absences be recognized for (1) leave that has not been used and (2) leave that has been used but not yet paid in cash or settled through noncash means. A liability should be recognized for leave that has not been used if (a) the leave is attributable to services already rendered, (b) the leave accumulates, and (c) the leave is more likely than not to be used for time off or otherwise paid in cash or settled through noncash means. Leave is attributable to services already rendered when an employee has performed the services required to earn the leave. Leave that accumulates is carried forward from the reporting period in which it is earned to a future reporting period during which it may be used for time off or otherwise paid or settled. In estimating the leave that is more likely than not to be used or otherwise paid or settled, a government should consider relevant factors such as employment policies related to compensated absences and historical information about the use or payment of compensated absences. However, leave that is more likely than not to be settled through conversion to defined benefit postemployment benefits should not be included in a liability for compensated absences.

City of Fairmont Emerging Issues

Accounting Standard Update – GASB Statement No. 101 – *Compensated Absences* (Continued)

This Statement requires that a liability for certain types of compensated absences – including parental leave, military leave, and jury duty leave – not be recognized until the leave commences. This Statement also requires that a liability for specific types of compensated absences not be recognized until the leave is used.

This Statement also establishes guidance for measuring a liability for leave that has not been used, generally using an employee's pay rate as of the date of the financial statements. A liability for leave that has been used but not yet paid or settled should be measured at the amount of the cash payment or noncash settlement to be made. Certain salary-related payments that are directly and incrementally associated with payments for leave also should be included in the measurement of the liabilities.

With respect to financial statements prepared using the current financial resources measurement focus, this Statement requires that expenditures be recognized for the amount that normally would be liquidated with expendable available financial resources.

This Statement amends the existing requirement to disclose the gross increases and decreases in a liability for compensated absences to allow governments to disclose only the net change in the liability (as long as they identify it as a net change). In addition, governments are no longer required to disclose which governmental funds typically have been used to liquidate the liability for compensated absences.

GASB Statement No. 101 is effective for reporting periods beginning after December 15, 2023. Earlier application is encouraged.

Information provided above was obtained from www.gasb.org.

Report on Compliance and Other Matters

As part of obtaining reasonable assurance about whether the City’s financial statements are free from material misstatement, we performed tests of its compliance with certain provisions of laws, regulations, contracts, and grant agreements, noncompliance with which could have a direct and material effect on the financial statements. However, providing an opinion on compliance with those provisions was not an objective of our audit, and accordingly, we do not express such an opinion. The results of our tests disclosed no instances of noncompliance or other matters that are required to be reported under *Government Auditing Standards*.

City's Responses to the Finding

Government Auditing Standards requires the auditor to perform limited procedures on the City's response to the findings identified in our audit are described in the accompanying Schedule of Findings and Responses on Internal Control. The City's response was not subjected to the other auditing procedures applied in the audit of the financial statements and, accordingly, we express no opinion on the response.

Purpose of this Report

The purpose of this report is solely to describe the scope of our testing of internal control and compliance and the result of that testing, and not to provide an opinion on the effectiveness of the City's internal control or on compliance. This report is an integral part of an audit performed in accordance with *Government Auditing Standards* in considering the City's internal control and compliance. Accordingly, this communication is not suitable for any other purpose.

BergankDV, Ltd.

St. Cloud, Minnesota
June 2, 2023

Minnesota Legal Compliance

Independent Auditor's Report

Honorable Mayor and Members
of the City Council
City of Fairmont
Fairmont, Minnesota

We have audited, in accordance with auditing standards generally accepted in the United States of America, and the standards applicable to financial audits contained in *Government Auditing Standards*, issued by the Comptroller General of the United States, the financial statements of the governmental activities, the business-type activities, the discretely presented component unit, each major fund, and the aggregate remaining fund information of the City of Fairmont, Minnesota as of and for the year ended December 31, 2022, and the related notes to financial statements, which collectively comprise the City's basic financial statements, and have issued our report thereon dated June 2, 2023.

In connection with our audit, nothing came to our attention that caused us to believe that the City failed to comply with the provisions of the contracting and bidding, deposits and investments, conflicts of interest, public indebtedness, claims and disbursements, miscellaneous provisions, and tax increment financing sections of the *Minnesota Legal Compliance Audit Guide for Cities*, promulgated by the State Auditor pursuant to *Minnesota Statutes* § 6.65, insofar as they relate to accounting matters. However, our audit was not directed primarily toward obtaining knowledge of such noncompliance. Accordingly, had we performed additional procedures, other matters may have come to our attention regarding the City's noncompliance with the above referenced provisions, insofar as they relate to accounting matters.

The purpose of this report is solely to describe the scope of our testing of compliance and the results of that testing, and not to provide an opinion on compliance. Accordingly, this communication is not suitable for any other purpose.

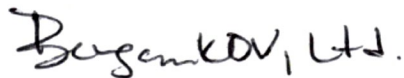

St. Cloud, Minnesota
June 2, 2023

City of Fairmont
Schedule of Findings and Responses on Internal Control

CURRENT YEAR INTERNAL CONTROL FINDING:

Material Weakness
Audit Finding 2022-001

Criteria:

Internal control that supports the City's ability to initiate record, process and report financial data requires adequate controls to ensure all required adjustments to the financial statements are properly recorded.

Condition:

During the course of our audit, we proposed a material audit adjustment that likely would not have been identified as a result of the City's existing internal controls, and therefore, could have resulted in a material misstatement of the District's financial statements. In order to ensure financial statements were free from material misstatement, an audit adjustment were required to adjust accrued payroll. Management and the City Council must remain aware of this situation and management should continually monitor the accounting system, including changes that occur.

Context:

This finding impacts the internal control over financial reporting.

Effect or Potential Effect:

Internal controls that fail to identify necessary adjustments could result in material misstatements to the financial statements.

Cause:

There are a limited number of office employees to identify all necessary adjustments.

Recommendation:

Review City activity and ensure all necessary adjustments to financial data are recorded.

Views of Responsible Officials and Planned Corrective Action:

The City will thoroughly review activity throughout the year and ensure all necessary adjustments to financial data are recorded.



Fairmont City Council
June 26, 2023

Agenda Item: 5

From: Mayor Baarts
To: Mayor and City Council
Subject: Mayor's Update

Budget Impact: N/A

Attachments: N/A

Council Action: _____ Date: _____



Fairmont City Council
June 26, 2023

Agenda Item: 6

From: City Administration
To: Mayor and City Council

Subject: Public Discussion/Comment

INDIVIDUAL COMMENTS ARE LIMITED TO 3 MINUTES

Overview: Prior to regular business, is there any public discussion/comment?

Budget Impact: N/A

Attachments: N/A

Council Action: _____ Date: _____



Fairmont City Council
June 26, 2023

Agenda Item: 7.A.1

From: Patricia J. Monsen, City Clerk
To: Mayor and City Council

Subject: Council Minutes from Regular Meeting on June 12, 2023

Policy/Action Requested: To Approve City Council Minutes from June 12, 2023

Vote Required: Simple Majority Roll Call

Recommendation: Approval

Overview:

Budget Impact: N/A

Attachments: City Council Minutes Regular Meeting, June 12, 2023

Council Action: _____ Date: _____

The minutes of the Fairmont City Council meeting held on Monday, June 12, 2023, at the City Hall Council Chambers.

Mayor Lee Baarts called the meeting to order at 5:30 p.m.

Council Members Wayne Hasek, Britney Kawecki, Randy Lubenow, Jay Maynard and Michele Miller were present. Also in attendance: Finance Director Paul Hoye, Director of Public Works/Utilities Matthew York, City Clerk Patricia Monsen, Police Chief Mike Hunter, Civil Engineer Tyler Cowing and City Attorney Cara Brown.

Mayor Baarts advised council that item 6.C.3 Request for Demolition Assistance by Michael Munsterman would be pulled from the agenda for further review and clarification.

Council Member Lubenow made a motion to pull item 6.C.1 Tobacco License and Sale of Edible Products Infused with Tetrahydrocannabinol License for Fairmont Smoke Shop and place it under new business for discussion. Council Member Kawecki seconded the motion. On roll call: Council Members Hasek, Kawecki, Lubenow, Maynard and Miller voted aye. No one voted nay. Mayor Baarts declared said motion passed.

Council Member Kawecki made a motion to add a bi-weekly discussion item to the agenda for updates on the city administrator and interim search. Council Member Lubenow seconded the motion and the motion carried.

Council Member Kawecki made a motion to add discussion regarding the council's decision to restrict the ability for council members to add items to the agenda. Council Member Lubenow seconded the motion. On roll call: Council Members Kawecki and Lubenow voted aye. Council Members Maynard, Miller and Hasek voted nay. Mayor Baarts declared said motion failed.

Council Member Miller made a motion to table item 9.4 Proposed Financing Structure of the Community Center based on lack of city involvement designing the facility, lack of a concrete agreement that the Fairmont Area Community Center Association is responsible for maintenance and upkeep for building and property so property taxes are not increased to fund all due to rushed work sessions so the Fairmont Area Community Center Association can secure outside funding when the city hasn't done this for other non-profit organizations in the community and especially when the city should be spending more time focusing on replacing the city administrator position. Council Member Hasek seconded the motion. On roll call: Council Members Miller and Hasek voted aye. Council Members Lubenow, Maynard and Kawecki voted nay. Mayor Baarts declared said motion failed.

Council Member Lubenow made a motion to approve the agenda with the removal of Item 6.C.3 Request for Demolition Assistance by Michael Munsterman, moving Item 6.C.1 Tobacco License and Sale of Edible Products Infused with Tetrahydrocannabinol License for Fairmont Smoke Shop to new business number 9.6, the addition of Item 10.1 Update on Hiring of the City Administrator and Interim Administrator. Council Member Maynard seconded the motion. On roll call: Council Members Lubenow, Maynard, Hasek and Kawecki voted aye. Council Member Miller voted nay. Mayor Baarts declared said motion passed.

Mayor Baarts thanked the Interlaken Heritage Days committee for all their hard work. He thanked the Fire Department for their response to the library fire today. Mayor Baarts announced all the events happening in the city for the next two weeks.

Mayor Baarts recognized Representative Bjorn Olson and Senator Rich Draheim for helping the city receive authorization from the Legislature to bring a proposed Local Option Sales Tax to the voters.

Finance Director Paul Hoye presented the 2022 Aquatic Park Annual Report. Hoye thanked Betsy Steuber and the aquatic park staff for taking such good care of the park.

During Open Discussion, David Wing, representing Congressman Brad Finstad's office addressed the council and gave an update on affordable housing and the city's wastewater treatment facility project.

City resident Greg Zierke complained about the potholes in the city streets.

Council Member Miller made a motion to approve the consent agenda. Council Member Hasek seconded the motion and the motion carried. Items on the consent agenda were: Minutes from the May 22, 2023 City Council meeting; Transient Merchant Permit for TNT Fireworks to sell fireworks in the Walmart parking lot; Request for Funding for the July 4th fireworks by Light, Noise and Smoke of Fairmont; Fireworks Display Permit for J & M Displays for July 1, 2023; Application for a Premises Gambling Permit for Charitable Gambling at the Bowlmor Lanes; Transient Merchant Permit for Jordan Carr to sell fireworks in the Loxley Coffee parking lot; and Purchase Order 14739 for the repair of storm sewer on Hall Street.

Council Member Kawecky made a motion to approve **Resolution 2023-20**, a resolution regarding the administration of the Minnesota Wetland Conservation Act. Council Member Maynard seconded the motion and the motion carried.

Council Member Maynard made a motion to approve the Maintenance and Operations Grant for SFY 24-25 and **Resolution 2023-23**. Council Member Miller seconded the motion and the motion carried.

Council Member Hasek made a motion to approve the Memorandum of Understanding with Fairmont Area Schools regarding a School Resource Officer Partnership. Council Member Miller seconded the motion and the motion passed.

Council Member Kawecky made a motion to adopt **Resolution 2023-21**, approving the proposed financing structure of the community center. Council Member Lubenow seconded the motion. On roll call: Council Members Kawecky, Lubenow and Maynard voted aye. Council Members Hasek and Miller voted nay. Mayor Baarts declared said motion passed.

Council Member Lubenow made a motion to temporarily amend the City Council Rules of Procedure adopted October 24, 2022 to designate Finance Director Paul Hoye and City Clerk Patricia Monsen to forward questions and concerns to the City Attorney until an Interim City Administrator or City Administrator is hired. Council Member Kawecky seconded the motion and the motion carried.

Council Member Maynard made a motion to approve the license for the sale of edible products infused with tetrahydrocannabinol and tobacco by Sammy Sarameh, d/b/a Fairmont Smoke Shop. Council Member Miller seconded the motion and the motion carried.

Mayor Baarts and Councilor Miller gave the council an update on the hiring process of a new city administrator and interim city administrator. A community survey will be posted on the city's website in English and Spanish for community input.

Public Works/Utilities Director York thanked the city for allowing him to come. He reported that a dry shaft went down at the Water Department, but that it would be repaired by the end of the week. Tomorrow is city wide cleanup. There is a project on Lair Road which will close the road on Wednesday and Thursday from 9:00 a.m. – 2:00 p.m. The City has been working with SMMPA on a transformer project and are in the final stages. He will be bringing before the council some jurisdictional changes in the near future. The Electrical Department has been trying to get electricity to a campground at the corner of 230th Avenue and 120th Street. The city has now obtained a permit with MnDOT to go under I-90. The band shell is in the final phase of drawings for the project, and it is expected to go out for bids in July. He has been busy working on a state bond for the proposed community center and will have that paperwork into the state legislature by the end of the week. York also gave an update on the repair of potholes.

Councilor Hasek reported that the Board of Zoning Appeals approved two projects which came before them.

Councilor Kawecky reported that the Planning Commission heard plans for industrial storage sheds which are “purchase to own” and are proposed to be built on the south side of Lake Avenue.

Councilor Lubenow stated that the HRA did not have a quorum. He stated that he will be volunteering to help with the city clean up, so if citizens need help, they may contact him.

Councilor Maynard reported that FEDA approved five more façade forgivable loans. They reviewed deed restriction on some land by Center Creek for a proposed new business. He also stated that there is now a contractor committed to building the twin homes in Whitetail Ridge.

Councilor Miller stated that Visit Fairmont just reviewed and discussed visitor guides and some drone photography. She also shared CER classes beginning in June and July.

A motion was made by Council Member Maynard, seconded by Council Member Hasek and carried to adjourn the meeting at 6:34 p.m.

Lee C. Baarts, Mayor

ATTEST:

Patricia J. Monsen, City Clerk



Fairmont City Council
June 26, 2023

Agenda Item: 7.B.1

From: Paul Hoyer, Finance Director
To: Mayor and City Council

Subject: Accounts Payable June 2023

Policy/Action Requested: To approve accounts payable for June 2023.

Vote Required: Simple Majority Roll Call

Recommendation: Approval of the payment of the June 2023 bills.

Overview:

Budget Impact: N/A

Attachments: June 2023 Bills – Attached at the end of the Council Agenda

Council Action: _____ Date: _____



Fairmont City Council
June 26, 2023

Agenda Item: 7.C.1

From: Patricia J. Monsen, City Clerk
To: Mayor and City Council

Subject: Event Permit – Cardinal Power Fastpitch Softball Tournament, July 8 & 9, 2023

Policy/Action Requested: Motion to approve the Event Permit for Cardinal Power Fastpitch Softball to hold a tournament on July 8 & 9, 2023 at Cardinal Park and Winnebago Sports Complex

Vote Required: Simple Majority Roll Call

Recommendation: Approval

Overview: Cardinal Power Fastpitch Softball has made application to hold a tournament on July 8 & 9, 2023.

Budget Impact: N/A

Attachments: Event Permit Application

Council Action: _____ Date: _____



EVENT APPLICATION/PERMIT

This form must be filed with the City at least thirty (30) days in advance of the event. The City will review the application in accordance with the permitting process outlined in the City Code, Chapter 18. Attach additional sheets, maps, etc. if necessary. For events which include overnight camping a separate addendum must be included with the event application.

Date: 4/22/23 Permit Fee: \$15.00

Event: Cardinal Power Fastpitch Softball Tournament

Sponsoring entity: Softball Association

Address: 1886 Knollwood Dr, Fairmont, MN 56031

Maximum estimated number of persons expected to attend at any one time: 500

Event coordinator(s): Meaghan Slama
Contact Info: 817-528-4326 Phone #
meaghanslama@gmail.com E-mail

Primary contacts (during event):
Name: Meaghan Slama Name: Amber Klauckner
Cell#: 817-528-4326 Cell#: 507-848-7074
E-mail: meaghanslama@gmail.com E-mail: _____

Event Start: Day/Date Saturday, July 8 Time: 8:00
Event End: Day/Date ~~Saturday, July 8~~ Sunday, July 9 Time: 5:00
Setup: Day/Date Friday, July 6 Start time: 6:00 pm End Time: _____
Teardown: Day/Date Sunday, July 9 Start time: _____ End Time: 8:00 pm

1. Type and description of the event and a list of all activities to take place at the event.
Girls softball tournament; approximately 30-40 teams;

2. Proposed location of event, including a site plan or diagram of the proposed area to be used showing the location of any barricades, perimeter/security fencing, fire extinguishers, safety or first aid stations, entertainment, stages, restrooms or portable toilets, parking areas, ingress and egress routes, signs, special lighting, trash containers and any other items related to the event.
Cardinal Park - Winnebago Diamonds

3. Will outside drinking water or waste collection systems be supplied? ___ Yes; No
If yes, supply public health plans, including the number of toilet facilities that will be available.

4. Will the event be providing: fire prevention, emergency medical service, security and severe weather shelter. ___ Yes; No
If yes, provide the written plans.

5. Will organizers allow outside food wagon/vendors at the event? Yes; ___ No
If yes, all food wagons/vendors must complete a Food Wagon/Vendor Permit and submit payment.

6. Will camping or temporary overnight lodging be included for the event? (allowed only at Cedar Creek Park and Winnebago Sports Complex): ___ Yes; No
If yes, event coordinator must complete temporary overnight camping permit and submit payment.

7. Will the event be using any sound amplification, public address system or will there be any live performances of any music or musical instruments? ___ Yes; No
If yes, please describe: _____

8. Will the event restrict or alter normal parking, vehicular traffic or pedestrian traffic patterns? ___ Yes; No
If yes, provide a detailed description of all public rights of way and private streets for which the applicant requests the city to restrict or alter traffic flow. (Please attach a detailed map).

9. Will you be providing shuttle service? ___ Yes; No
If yes, provide offsite parking locations, shuttle routes, types of vehicles that will be used for shuttling passengers, hours of operation and frequency of shuttle service.

I affirm that I am authorized to execute this application on behalf of the applicant and that the statements contained therein are true and correct to the best of my knowledge. If the special event requires special services provided by the City of Fairmont, the applicant agrees to indemnify, defend and hold the City of Fairmont, its officials, employees, and agents harmless from any claim that arises in whole or in part out of the special event, except any claims arising solely out of the negligent acts or omissions of the City of Fairmont, its officials, employees and agents. The applicant agrees to pay all fees and meet all City Code requirements.

Signature: Megha So Title: Board Member Date: 6/22/23

If you would like your event published on the City's website/Community Calendar, please indicate: Yes; ___ No

Office Use Only

\$15.00 Fee Paid	Date:	Received by:	
Requires Council Approval	___ Yes; ___ No	Council Meeting Date:	Action:
City Administrator Approval	Yes	No	Date

- Permit distribution:
- ___ City
 - ___ Applicant
 - ___ Police
 - ___ Parks/Streets
 - ___ Other



Fairmont City Council
June 26, 2023

Agenda Item: 7.C.2

From: Patricia J. Monsen, City Clerk
To: Mayor and City Council

Subject: Event Permit – Latin Festival, July 29, 2023

Policy/Action Requested: Motion to approve the Event Permit for Melendez Contracting, LLC and Las Potrancas Mexican Store for a Latin Festival on July 29, 2023 on Downtown Plaza.

Vote Required: Simple Majority Roll Call

Recommendation: Approval

Overview:

Melendez Contracting, LLC and Las Potrancas Mexican Store has made application to hold a Latin Festival on Downtown Plaza between Second and Third Street on July 29, 2023. This will be a family fun event and will include food wagons.

Budget Impact: N/A

Attachments: Event Permit Application

Council Action: _____ Date: _____



EVENT APPLICATION/PERMIT

This form must be filed with the City at least thirty (30) days in advance of the event. The City will review the application in accordance with the permitting process outlined in the City Code, Chapter 18. Attach additional sheets, maps, etc. if necessary. For events which include overnight camping a separate addendum must be included with the event application.

Date: 6/20/23

Permit Fee: \$15.00

Event: Latin Festival

Sponsoring entity: Melendez Contracting LLC - Las Potrancas Mexican Sore

Address: 220 Downtown Plaza

Maximum estimated number of persons expected to attend at any one time: 1000 + plus

Event coordinator(s): Jonathan melendez, Ramon Vega
Contact Info: 507-381 1653 Phone #
E-mail

Primary contacts (during event):

Name: Jonathan melendez
Cell#: 507 381 1653
E-mail:

Name: OSCAR OCHOA
Cell#: 507 230 1913
E-mail:

Event Start:	Day/Date	<u>7/29/23</u>	Time:	<u>12pm</u>
Event End:	Day/Date	<u>7/29/23</u>	Time:	<u>11pm</u>
Setup:	Day/Date	<u>7/29/23</u>	Start time:	<u>8am</u>
Teardown:	Day/Date	<u>7/30/23</u>	Start time:	<u>8am</u>
			End Time:	<u>12pm</u>
			End Time:	<u>12pm</u>

1. Type and description of the event and a list of all activities to take place at the event.

It will be a latin festival to celebrate the presence of hispanic community in Fairmont there will be live music, car show food vendors games and activities for kids and adults

2. Proposed location of event, including a site plan or diagram of the proposed area to be used showing the location of any barricades, perimeter/security fencing, fire extinguishers, safety or first aid stations, entertainment, stages, restrooms or portable toilets, parking areas, ingress and egress routes, signs, special lighting, trash containers and any other items related to the event.

Downtown Plaza between close end of 2nd street and 3rd street Bands will set up in front of mexican store address will be 220 downtown plaza

barricades - to block the intersection of DTP + 2nd St. and 3 for 3rd Street extra garbage cans

3. Will outside drinking water or waste collection systems be supplied? ~~Yes~~ Yes; No
 If yes, supply public health plans, including the number of toilet facilities that will be available.

4. Will the event be providing: fire prevention, emergency medical service, security and severe weather shelter. Yes; No
 If yes, provide the written plans.

5. Will organizers allow outside food wagon/vendors at the event? Yes; No
 If yes, all food wagons/vendors must complete a Food Wagon/Vendor Permit and submit payment.

6. Will camping or temporary overnight lodging be included for the event? (allowed only at Cedar Creek Park and Winnebago Sports Complex): Yes; No
 If yes, event coordinator must complete temporary overnight camping permit and submit payment.

7. Will the event be using any sound amplification, public address system or will there be any live performances of any music or musical instruments? Yes; No
 If yes, please describe: Hispanic bands and live music

8. Will the event restrict or alter normal parking, vehicular traffic or pedestrian traffic patterns? Yes; No
 If yes, provide a detailed description of all public rights of way and private streets for which the applicant requests the city to restrict or alter traffic flow. (Please attach a detailed map).

9. Will you be providing shuttle service? Yes; No
 If yes, provide offsite parking locations, shuttle routes, types of vehicles that will be used for shuttling passengers, hours of operation and frequency of shuttle service.

I affirm that I am authorized to execute this application on behalf of the applicant and that the statements contained therein are true and correct to the best of my knowledge. If the special event requires special services provided by the City of Fairmont, the applicant agrees to indemnify, defend and hold the City of Fairmont, its officials, employees, and agents harmless from any claim that arises in whole or in part out of the special event, except any claims arising solely out of the negligent acts or omissions of the City of Fairmont, its officials, employees and agents. The applicant agrees to pay all fees and meet all City Code requirements.

Signature: *Soraida Melendez* Title: _____ Date: 6/20/23

If you would like your event published on the City's website/Community Calendar, please indicate: Yes; No

Office Use Only			
\$15.00 Fee Paid	Date: <u>6/20/23</u>	Received by: <u><i>RM</i></u>	
Requires Council Approval	<input checked="" type="checkbox"/> Yes; <input type="checkbox"/> No	Council Meeting Date: <u>6/26/23</u>	Action:
City Administrator Approval	Yes	No	Date

- Permit distribution:
- City
 - Applicant
 - Police
 - Parks/Streets
 - Other



Fairmont City Council
June 26, 2023

Agenda Item: 7.C.3

From: Patricia J. Monsen, City Clerk
To: Mayor and City Council

Subject: On Sale Liquor License for Bean Town Grill, LLC, d/b/a Bean Town Grill

Policy/Action Requested: Motion to approve an On Sale Liquor License for Bean Town Grill, LLC, d/b/a Bean Town Grill, pending a satisfactory background check.

Vote Required: Simple Majority Roll Call

Recommendation: Approval

Overview: The Parra family has purchased Bean Town Grill and Karen Parra has made application for an On Sale Liquor License for Bean Town Grill, LLC, d/b/a Bean Town Grill. The paperwork has been completed, the fees have been paid and a background check has been requested. Because of the timing of this transfer of ownership, I am asking for approval of the On Sale Liquor License pending a successful background investigation.

Budget Impact: N/A

Attachments:

Council Action: _____ Date: _____



Fairmont City Council
June 26, 2023

Agenda Item: 7.C.4

From: Patricia J. Monsen, City Clerk
To: Mayor and City Council

Subject: Temporary On-Sale Liquor License for Forever Emmalyne

Policy/Action Requested: To Approve the Temporary On-Sale Liquor License for Forever Emmalyne to hold an event on July 22, 2023.

Vote Required: Simple Majority Roll Call

Recommendation: Approval

Overview: Forever Emmalyne has applied for a temporary on-sale liquor license for an event to be held at 83 Downtown Plaza on July 22, 2023.

Budget Impact: N/A

Attachments: Application

Council Action: _____ Date: _____



Minnesota Department of Public Safety
 Alcohol and Gambling Enforcement Division
 445 Minnesota Street, Suite 1600, St. Paul, MN 55101
 651-201-7507 Fax 651-297-5259 TTY 651-282-6555
**APPLICATION AND PERMIT FOR A 1 DAY
 TO 4 DAY TEMPORARY ON-SALE LIQUOR LICENSE**

Name of organization: Forever Emmalyne Date organized: 03/2020 Tax exempt number: 84-4300550

Address: 324 165th Ave City: Ceylon State: MN Zip Code: 56121

Name of person making application: Laura Spitzer Business phone: 507-236-5554 Home phone: 507-236-1647

Date(s) of event: July 22, 2023 Type of organization: Microdistillery Small Brewer
 Club Charitable Religious Other non-profit

Organization officer's name: Laura Spitzer City: Ceylon State: MN Zip Code: 56121

Organization officer's name: Tom Spitzer City: Ceylon State: MN Zip Code: 56121

Organization officer's name: Carter Spitzer City: Ceylon State: MN Zip Code: 56121

Location where permit will be used. If an outdoor area, describe.
83 Downtown Plaza, Fairmont, MN 56031

If the applicant will contract for intoxicating liquor service give the name and address of the liquor license providing the service.
N/A

If the applicant will carry liquor liability insurance please provide the carrier's name and amount of coverage.

APPROVAL

APPLICATION MUST BE APPROVED BY CITY OR COUNTY BEFORE SUBMITTING TO ALCOHOL AND GAMBLING ENFORCEMENT

<u>City of Fairmont</u> (City) or County approving the license	Date Approved <u>July 22, 2023</u>
<u>\$50.00</u> Fee Amount	Permit Date <u>July 22, 2023</u>
Date Fee Paid	<u>pmonseng@fairmont.org</u> (City) or County E-mail Address
Signature City Clerk or County Official	<u>507-238-3935</u> (City) or County Phone Number
	<u>Patricia J. Monsen, City Clerk</u> Please Print Name of City Clerk or County Official

CLERKS NOTICE: Submit this form to Alcohol and Gambling Enforcement Division 30 days prior to event.

**ONE SUBMISSION PER EMAIL, APPLICATION ONLY.
 PLEASE PROVIDE A VALID E-MAIL ADDRESS FOR THE CITY/COUNTY AS ALL TEMPORARY
 PERMIT APPROVALS WILL BE SENT BACK VIA EMAIL. E-MAIL THE APPLICATION SIGNED BY
 CITY/COUNTY TO AGE.TEMPORARYAPPLICATION@STATE.MN.US**



Fairmont City Council
June 26, 2023

Agenda Item: 10.1

From: Tyler Cowing, Civil Engineer
To: Mayor and City Council

Subject: 2023 Preparing for Emerald Ash Borer, Minnesota DNR Grant Agreement

Policy/Action Requested: Motion authorizing the City of Fairmont to enter into a Grant Agreement with the State of Minnesota.

Vote Required: Simple Majority Roll Call

Recommendation: Approval

Overview: The City of Fairmont was awarded a Preparing for Emerald Ash Bore Grant in the amount of \$4,600. These funds will be used to purchase GPS equipment which our MPCA Greencorps member will use conduct a tree inventory in the city. Requirements of the agreement include a GIS datasheet of trees inventoried and an Emerald Ash Bore Management plan. The city’s Greencorps member will be working with park and engineering staff to complete these efforts in 2023 and 2024.

Budget Impact: \$4600 which is reimbursable upon completion of grant agreement requirements.

Attachments: Grant Agreement

Council Action: _____ Date: _____

STATE OF MINNESOTA GRANT CONTRACT AGREEMENT

This grant contract agreement is between the State of Minnesota, acting through its Department of Natural Resources, Division of Forestry, 500 Lafayette Road, St. Paul, MN 55155 ("STATE") and City of Fairmont, 100 Downtown Plaza, Fairmont, MN 56031 ("GRANTEE").

Recitals

1. Under Minn. Stat. §84.026, §84.085, Subd. 1, and Minnesota Session Laws 2021, 1st Special Session, Chapter 6, Article 1, Sec. 3, Subd. 4 (j) the State is empowered to enter into this grant contract agreement.
2. The State is in need of Urban and Community Forestry Services for the Preparing for Emerald Ash Borer project.
3. The Grantee represents that it is duly qualified and agrees to perform all services described in this grant contract agreement to the satisfaction of the State. Pursuant to [Minn.Stat. §16B.98](#), Subd.1, the Grantee agrees to minimize administrative costs as a condition of this grant contract agreement.

Grant Contract Agreement

1 Term of Grant Contract Agreement

1.1 *Effective date:*

July 1, 2023, Per [Minn. Stat. §16B.98](#), Subd. 5, the Grantee must not begin work until this grant contract agreement is fully executed and the State's Authorized Representative has notified the Grantee that work may commence. Per [Minn.Stat. §16B.98](#) Subd. 7, no payments will be made to the Grantee until this grant contract agreement is fully executed.

1.2 *Expiration date:*

June 30, 2025, or until all obligations have been satisfactorily fulfilled, whichever occurs first.

1.3 *Survival of Terms.*

The following clauses survive the expiration or cancellation of this grant contract agreement: 8. Liability; 9. State Audits; 10. Government Data Practices and Intellectual Property; 12. Publicity and Endorsement; 13. Governing Law, Jurisdiction, and Venue; and 15 Data Disclosure.

2 Grantee's Duties

The Grantee, who is not a state employee, will:

Comply with required grants management policies and procedures set forth through [Minn.Stat. §16B.97](#), Subd. 4 (a) (1).

Perform the duties specified in Exhibit A and Exhibit B which are incorporated and made a part of this agreement.

3 Time

The Grantee must comply with all the time requirements described in this grant contract agreement. In the performance of this grant contract agreement, time is of the essence.

4 Consideration and Payment

4.1 *Consideration.*

The State will pay for all services performed by the Grantee under this grant contract agreement as follows:

(a) Compensation

The Grantee will be paid in an amount not to exceed \$4,600.00 on a reimbursement basis for qualifying purchases. The Grantee shall submit payment requests with required expenditure documentation.

According to the breakdown of costs contained in Exhibit B, which is attached and incorporated into this grant contract, the Grantee certifies that a minimum 0% matching requirement for the grant will be met by the City of Fairmont. The total project cost is \$6,900.00. Grantee agrees to match at least \$2,300.00 of this project cost.

(b) Travel Expenses

Reimbursement for travel and subsistence expenses actually and necessarily incurred by the Grantee as a result of this grant contract agreement will not exceed \$0.00; provided that the Grantee will be reimbursed for travel and subsistence expenses in the same manner and in no greater amount than provided in the current "Commissioner's Plan" promulgated by the Commissioner of Minnesota Management and Budget (MMB). The Grantee will not be reimbursed for travel and subsistence expenses incurred outside Minnesota unless it has received the State's prior written approval for out of state travel. Minnesota will be considered the home state for determining whether travel is out of state.

(c) Total Obligation.

The total obligation of the State for all compensation and reimbursements to the Grantee under this grant contract agreement will not exceed \$4,600.00.

4.2 Payment

(a) Invoices

The State will promptly pay the Grantee after the Grantee presents an itemized invoice for the services actually performed and the State's Authorized Representative accepts the invoiced services. Invoices must be submitted timely and according to the following schedule:

1. January 8, 2024
2. July 1, 2024
3. January 6, 2025
4. June 30, 2025

The State shall disburse funds to the Grantee pursuant to this agreement on a reimbursement basis. The Grantee shall submit payment requests with required expenditure documentation. All project work must be completed and the final request for reimbursement (along with final reports) must be submitted by June 30, 2025.

(b) Unexpended Funds

The Grantee must promptly return to the State any unexpended funds that have not been accounted for annually in a financial report to the State due at grant closeout.

4.3 Contracting and Bidding Requirements

Per [Minn. Stat. §471.345](#), grantees that are municipalities as defined in Subd. 1 must follow the law.

(a) For projects that include construction work of \$25,000 or more, prevailing wage rules apply per [Minn. Stat. §§177.41](#) through [177.44](#). These rules require that the wages of laborers and workers should be comparable to wages paid for similar work in the community as a whole.

(b) The grantee must not contract with vendors who are suspended or debarred in MN: <http://www.mmd.admin.state.mn.us/debarredreport.asp>

5 Conditions of Payment

All services provided by the Grantee under this grant contract agreement must be performed to the State's satisfaction, as determined at the sole discretion of the State's Authorized Representative and in accordance with all applicable federal, state, and local laws, ordinances, rules, and regulations. The Grantee will not receive payment for work found by the State to be unsatisfactory or performed in violation of federal, state, or local law.

6 Authorized Representative

The State's Authorized Representative is Emma Schultz, Community Forest Project Specialist, 500 Lafayette Rd., St. Paul, MN 55155, 651-259-5274, ucf.dnr@state.mn.us, or his/her successor, and has the

responsibility to monitor the Grantee's performance and the authority to accept the services provided under this grant contract agreement. If the services are satisfactory, the State's Authorized Representative will certify acceptance on each invoice submitted for payment.

The Grantee's Authorized Representative is Tyler Cowing, Civil Engineer, 100 Downtown Plaza, Fairmont, MN 56031, (507) 238-3948, tcowing@fairmont.org. If the Grantee's Authorized Representative changes at any time during this grant contract agreement, the Grantee must immediately notify the State.

7 Assignment Amendments, Waiver, and Grant Contract Agreement Complete

7.1 Assignment

The Grantee shall neither assign nor transfer any rights or obligations under this grant contract agreement without the prior written consent of the State, approved by the same parties who executed and approved this grant contract agreement, or their successors in office.

7.2 Amendments

Any amendments to this grant contract agreement must be in writing and will not be effective until it has been executed and approved by the same parties who executed and approved the original grant contract, or their successors in office.

7.3 Waiver

If the State fails to enforce any provision of this grant contract agreement, that failure does not waive the provision or the State's right to enforce it.

7.4 Grant Contract Agreement Complete

This grant contract agreement contains all negotiations and agreements between the State and the Grantee. No other understanding regarding this grant contract, whether written or oral, may be used to bind either party.

8 Liability

The Grantee must indemnify, save, and hold the State, its agents, and employees harmless from any claims or causes of action, including attorney's fees incurred by the State, arising from the performance of this grant contract agreement by the Grantee or the Grantee's agents or employees. This clause will not be construed to bar any legal remedies the Grantee may have for the State's failure to fulfill its obligations under this grant contract agreement.

9 State Audits

Under Minn. Stat. § 16B.98, Subd.8, the Grantee's books, records, documents, and accounting procedures and practices of the Grantee or other party relevant to this grant contract agreement or transaction are subject to examination by the State and/or the State Auditor or Legislative Auditor, as appropriate, for a minimum of six years from the end of this grant contract agreement, receipt and approval of all final reports, or the required period of time to satisfy all state and program retention requirements, whichever is later.

10 Government Data Practices and Intellectual Property Rights

10.1 Government Data Practices

The Grantee and State must comply with the Minnesota Government Data Practices Act, [Minn. Stat. Ch. 13](#), as it applies to all data provided by the State under this grant contract, and as it applies to all data created, collected, received, stored, used, maintained, or disseminated by the Grantee under this grant contract agreement. The civil remedies of [Minn. Stat. §13.08](#) apply to the release of the data referred to in this clause by either the Grantee or the State. If the Grantee receives a request to release the data referred to in this Clause, the Grantee must immediately notify the State. The State will give the Grantee instructions concerning the release of the data to the requesting party before the data is released. The Grantee's response to the request shall comply with applicable law

10.2 Intellectual Property Rights

The State owns all rights, title, and interest in all of the intellectual property rights, including copyrights, patents, trade secrets, trademarks, and service marks in the Works and Documents created

and paid for under this contract. If intellectual property rights are identified, the grantee must contact the DNR immediately.

11 Workers Compensation

The Grantee certifies that it is in compliance with [Minn. Stat. §176.181](#), Subd. 2, pertaining to workers' compensation insurance coverage. The Grantee's employees and agents will not be considered State employees. Any claims that may arise under the Minnesota Workers' Compensation Act on behalf of these employees and any claims made by any third party as a consequence of any act or omission on the part of these employees are in no way the State's obligation or responsibility.

12 Publicity and Endorsement

12.1 *Publicity*

Any publicity regarding the subject matter of this grant contract agreement must identify the State as the sponsoring agency and must not be released without prior written approval from the State's Authorized Representative. For purposes of this provision, publicity includes notices, informational pamphlets, press releases, research, reports, signs, and similar public notices prepared by or for the Grantee individually or jointly with others, or any subcontractors, with respect to the program, publications, or services provided resulting from this grant contract. All projects primarily funded by state grant appropriations must publicly credit the State of Minnesota, including on the grantee's website when practicable.

12.2 *Endorsement*

The Grantee must not claim that the State endorses its products or services.

13 Governing Law, Jurisdiction, and Venue

Minnesota law, without regard to its choice-of-law provisions, governs this grant contract agreement. Venue for all legal proceedings out of this grant contract agreement, or its breach, must be in the appropriate state or federal court with competent jurisdiction in Ramsey County, Minnesota.

14 Termination

14.1 *Termination by the State*

The State may immediately terminate this grant contract agreement with or without cause, upon 30 days' written notice to the Grantee. Upon termination, the Grantee will be entitled to payment, determined on a pro rata basis, for services satisfactorily performed.

14.2 *Termination for Cause*

The State may immediately terminate this grant contract agreement if the State finds that there has been a failure to comply with the provisions of this grant contract, that reasonable progress has not been made or that the purposes for which the funds were granted have not been or will not be fulfilled. The State may take action to protect the interests of the State of Minnesota, including the refusal to disburse additional funds and requiring the return of all or part of the funds already disbursed.

14.3 *Termination for Insufficient Funding*

The State may immediately terminate this grant contract agreement if:

- (a)** It does not obtain funding from the Minnesota Legislature
- (b)** Or, if funding cannot be continued at a level sufficient to allow for the payment of the services covered here. Termination must be by written or fax notice to the Grantee. The State is not obligated to pay for any services that are provided after notice and effective date of termination. However, the Grantee will be entitled to payment, determined on a pro rata basis, for services satisfactorily performed to the extent that funds are available. The State will not be assessed any penalty if the grant contract agreement is terminated because of the decision of the Minnesota Legislature, or other funding source, not to appropriate funds. The State must provide the Grantee notice of the lack of funding within a reasonable time of the State's receiving that notice.

14.4 *Additional Alternate Termination Language*

Additional alternate termination language may be negotiated on a case-by-case basis after the state

agency has consulted with their legal and finance teams.

15 Data Disclosure

Under [Minn. Stat. § 270C.65](#), Subd. 3, and other applicable law, the Grantee consents to disclosure of its social security number, federal employer tax identification number, and/or Minnesota tax identification number, already provided to the State, to federal and state tax agencies and state personnel involved in the payment of state obligations. These identification numbers may be used in the enforcement of federal and state tax laws which could result in action requiring the Grantee to file state tax returns and pay delinquent state tax liabilities, if any.

1. STATE ENCUMBRANCE VERIFICATION

Individual certifies that funds have been encumbered as required by Minn. Stat. § 16A.15

DocuSigned by:
Laura Larson
Signed: _____
Date: June 21, 2023

SWIFT Contract/PO No(s). 229365 / 3-230483

Funds are available but FY24 budgets are not loaded. Per the Admin Policy 21-01 exception, funds will be encumbered as soon as possible but no later than 8/31/23.

2. GRANTEE

The Grantee certifies that the appropriate person(s) have executed the grant contract agreement on behalf of the Grantee as required by applicable articles, bylaws, resolutions, or ordinances.

By: _____
Title: _____
Date: _____

By: _____
Title: _____
Date: _____

3. STATE AGENCY

By: _____
(with delegated authority)

Title: Deputy Director

Date: _____

Distribution:
Agency
Grantee
State's Authorized Representative

Exhibit A: Grant Project Deliverables

2023 Preparing for Emerald Ash Borer

City of Fairmont Deliverables

Grant Sum Total: \$4,600.00

Grant Contact Deliverables

- Adopting an EAB management plan through this grant process if the community does not yet have one in place
- Each ash tree removed must be replaced with a newly planted tree
- Grantee must be willing to participate in work by the Minnesota Department of Agriculture and University of Minnesota to evaluate project impacts

Regardless of requests for reimbursement, a written update must be submitted by each reporting deadline, to insure project is moving forward and on track to completion. Add written reports below corresponding to each reporting date:

January 8, 2024 Update:

July 1, 2024 Update:

January 6, 2025 Update:

June 30, 2025 Update:

*As work is completed, thoroughly address all applicable bullet points below. Add in the date of reporting (i.e. 1/8/24) and change the font color of your update to **red**, to show where information has been added. Continually add to this document over the lifetime of your grant, making sure that all bullet points are addressed by the time of the grant's completion.*

Work with DNR to fully execute and report on the impacts of the work plan by meeting the requirements as submitted in the City of Fairmont's application:

Project Overview and Need

The City of Fairmont is requesting funding for a city-wide tree inventory project to detect ash trees which may be infected with the Emerald Ash Borer, to map healthy ash trees, and to inventory other tree species so we can ensure future plantings are diverse.

- We will use the funding to purchase GPS equipment to map all trees on public land within city limits, and each data point will be associated with the species of tree and the status of EAB infection.

We intend to host a GreenCorps member or city-funded Intern who will be working on this project. This project will include public land within the City's Environmental Justice Area (See Environmental Justice Map). This person will work in conjunction with staff members who are certified by the DNR to detect and pinpoint EAB infected trees. This data will be used in a future project to remove and replace unhealthy ash trees with a diverse population of young and healthy tree species. Data will be supplied to the DNR via shapefiles. Without the funding for the GPS equipment we will not be able to complete an accurate tree inventory. Although the number of ash trees in our city is currently unknown, all of our public areas have trees, and most have mature ash trees, as they were a common planting at one time. Our citizens use our parks, trails, and shorelines frequently for recreation in all seasons. (Please See Attached City Parks Map, Bike Trails Map, and Snowmobile Trail map) The hazards of dead or diseased ash trees include falling branches and, in some cases, falling trees, which could result in injury and

possible death, especially in winter with increased snow load on EAB infected trees. In addition, removing diseased and dead ash trees will slow the infection rate, and help stymie the spread of EAB overall in our city.

Project Timeline

Through this funding we plan to gain the knowledge of what species of trees are in our public spaces, how many are Ash trees, and how many Ash trees are infested, along with their locations. At the end of this project, we will have a complete, interactive, GIS map of all the trees on Public Property, along with the locations of all Ash trees and the locations of EAB infestations. We intend on prioritizing Boulevards, then moving to Parks and other Public Areas, with an emphasis on our EJ areas. After the funding from this grant has ended, we fully intend on furthering the project by analyzing the collected data of our current tree inventory. Once we know the species that exist, where they are located and if they are currently infested with EAB we will develop plans for a city-wide tree replacement which may include additional plantings to what was originally there. This is expected to be continued and accomplished by a GreenCorps Member or city-funded Intern in the coming years.

- Fall 2023- GIS tree data collection begins on Boulevards.
- Winter 2023- EAB management plan is developed. Data collected thus far is imported and mapped in GIS. Spring/summer 2024- GIS tree data collection begins on Parks and Public Areas.
- Late summer 2024- Data Collection will be completed. All data collected during this project will be imported, attributed, and mapped.

Project Budget Explanation

The City of Fairmont is leveraging support through hosting a GreenCorps member or city-funded Intern at our site to help with this project, which will save additional costs over using a hired contractor, as well as extending additional support, experience, and training to a young environmental professional. If a GreenCorps member is not secured at our location we can use a city funded Intern to complete this work.

- The City is asking for \$4,600 for GPS equipment for data collection.
- \$1800 for mileage and vehicle expense (\$20.57/day for 87 days) would be provided as an In-Kind Match. In addition, we would provide \$500 as an In-Kind Match for any office supplies the GreenCorps Member or city funded intern might need to perform their job.

Project Impacts on Priority Landscapes and Populations

The City of Fairmont has a significant portion of its population in an Environmental Justice area, as shown on the attached map.

- We plan on educating this area on EAB infestations using flyers and doorhangers, as well as other general public outreach conducted by the chosen GreenCorps member or City funded Intern.

The majority of our EJ area is an older part of the community which has been around for some time. This area has larger trees with thicker canopies and larger limbs. If these trees are infested with EAB and they fall or shed branches there is a much larger potential for damage to personal property, and infrastructure damage. These trees could also cause injuries and possible death. The EJ area in our community is considered a low-income area, and these citizens are less likely to be able to finance a repair on a home due to a large falling branch, or fully pay a medical bill due to injury by a falling tree. In addition, these citizens likely don't have the flexibility to take the time off of work to manage problems

due to fallen diseased trees. The costs of such damage, whether it is property or injury will be substantial. It is imperative that the EAB situation is addressed in our EJ areas in particular.

Communication

The City of Fairmont plans to use a variety resources to engage with the public about the EAB project if awarded.

- The city would use its social media pages, website, local newspaper, updates during city council meetings, and utility billing stuffers to inform about the project and how completing a tree inventory and EAB management plan will help the city manage its urban forest, and help budget for EAB related costs.

Key Personnel

- Chad Striemer, Bachelor of Science City Forester - UMN MN Tree Inspector Certification. Chad has worked as the City Forester for 24 years and has a great understanding of the EAB situation in our city, as well as having a great background in urban forestry. In addition, he has his tree inspector's liscense through the MN DNR.
- Nick Lardy, Parks Department Superintendent - UMN MN Tree Inspector Certification. Nick has worked as the Parks Department and Street Department Superintendent for 9 years, and has taken on many large projects during his time with the city, and knows the city very well. In addition, he has his tree inspector's liscense through the MN DNR.
- Tyler Cowing, Civil Engineer - B.S. Atmospheric Sciences, M.S. Water Resources- Civil Engineering. Tyler has worked in the City Engineering Department for 11 years. during his time with the City he has worked on several construction projects which involve urban forestry. Street reconstruction projects and City Park renovations are a couple examples of these projects. He also has a good understanding of trees and their benefits due to his work with the City's Stormwater Management Program.

Tree Planting

Grant funds will not fund the purchase of trees that are over-represented in your community. Any genera that comprise 10% or more of the community forest make-up will not be funded. Numbers derived from the Minnesota Department of Natural Resources 2010 Rapid Assessment will be used unless an updated inventory is provided. For your community this means grant funds cannot be spent on purchasing:

- *Acer* (maple): 28.7%
- *Fraxinus* (ash): 21.4%
- *Picea* (spruce): 17.4%

All trees planted with grant funds are expected to be maintained based on the City of Fairmont's Three Year Tree Maintenance Plan submitted as Exhibit C. Trees that do not survive will need to be replaced prior to grant close-out utilizing the warranty the city has with the nursery that stock was purchased from, or at the expense of the City of Fairmont.

Requesting Reimbursement

Accomplishment reports and maps of completed work will be submitted with all requests for reimbursement.

- Partial payment form along with invoices and proof of payment for grant-funded purchases, Cash Match form along with proof of payment, and In-Kind Match form
- Partial payments may be submitted as needed and must include all up-to-date required documents and accomplishment reports, including a relevant certification and/or declaration
- Accomplishment reports will include grant contract deliverables and their impacts
- Photo documentation of the project's progress at appropriate phases, and illustrations, diagrams, charts, graphs, and maps to show results
- Maps will:
 - Identify the location of ash that have been removed
 - Identify the location of ash stumps that have been ground
 - Identify the location and species of trees that have been planted
 - Identify the location of ash trees that have been treated
- All trees removed, treated, and planted will be mapped and submitted as shapefiles, with the planted trees identified by species and size, to obtain grant fund reimbursement. If your community does not have access to shapefile-generating software, please notify your DNR Urban and Community Forestry Team Member, and they will work to assist you.

Following the submission of invoices and accomplishment reports, a compliance check will be conducted by Minnesota Department of Natural Resources staff. Staff will do a site evaluation ensuring that tree species submitted on maps are correctly identified and planted in accordance with the standards set in the Minnesota Department of Natural Resources [Pocket Guide to Planting Trees](#).

Staff will also ensure that the project adheres to the 20-10-5 guideline which means that following planting, a community has no more than 20% of their trees within a single family, no more than 10% of their trees within a single genus, and no more than 5% of their trees within a single species. Staff will confirm that planted tree stock is ¾"-2" caliper bareroot or a container class size #20 or smaller.

Ineligible Project Expenses

Ineligible project expenses include, but are not limited to:

- Costs incurred prior to the start date on the fully executed grant agreement
- Staff time for local government unit employees
- Purchase of trees listed on the [Minnesota Invasive Terrestrial Plants](#) and [Minnesota Noxious Weed](#) lists, including Amur cork tree, Amur maple, autumn olive, black locust, buckthorn, Callery pear, Norway maple, Russian olive, Siberian elm, Tatarian maple, and tree of heaven
- Purchase of balled and burlapped trees, containerized trees larger than #20, and bareroot trees greater than 2" caliper diameter
- Purchase of tree species that already make up 10% or more of the community's public trees, or whose family makes up 20% or more of the public trees
- Purchase of plants such as shrubs, living ground covers, sod, grass seed, and flowers
- Purchase of land or easements
- Major soil and grade changes or construction
- Equipment purchases equal to or exceeding \$5,000
- Purchase of meals or snacks for volunteers
- Experimental practices not approved by DNR

Acknowledgments

Minnesota Department of Natural Resources

The Minnesota Department of Natural Resources needs to be acknowledged in publications, audiovisuals, and electronic media developed as a result of this award.

- Including any publications or outreach materials related to this grant or agreement, a statement of affiliation with Minnesota Department of Natural Resources, e.g., “This publication made possible through a grant from the Minnesota Department of Natural Resources.” OR “This project was conducted in cooperation with the Minnesota Department of Natural Resources.”
- Logo is permitted for use and can be obtained by contacting the UCF Team.

Exhibit B: Project Budget
2023 Preparing for Emerald Ash Borer
 City of Fairmont

Item	State Grant Funds	Cash Match	In-kind Match	Total
Personnel and Owned Equipment			\$2,300.00	\$2,300.00
Eligible Expenses	\$4,600.00			\$4,600.00
Totals	\$4,600.00	\$0.00	\$2,300.00	\$6,900.00



Minnesota Department of Natural Resources

Conflict of Interest Disclosure

Conflict of Interest:

A conflict of interest occurs when a person has actual or apparent duty or loyalty to more than one organization and the competing duties or loyalties may result in actions which are adverse to one or both parties. A conflict of interest exists even if no unethical, improper or illegal act results from it.

Actual Conflict of Interest:

An actual conflict of interest occurs when a person's decision or action would compromise a duty to a party without taking immediate appropriate action to eliminate the conflict. Examples include, but are not limited to:

- One party uses his or her position to obtain special advantage, benefit, or access to the other party's time, services, facilities, equipment, supplies, badge, uniform, prestige, or influence.
- One party receives or accepts money (or anything else of value) from another party or has equity or a financial interest in or partial or whole ownership of the other party's organization.
- One party is an employee, board member or family member of the other party.

Potential Conflict of Interest:

A potential conflict of interest may exist if a person has a relationship, affiliation, or other interest that could create an inappropriate influence if the person is called on to make a decision or recommendation that would affect one or more of those relationships, affiliations, or interests.

Organizational Conflict of Interest:

A conflict of interest can also occur with an organization that is a grant applicant in a competitive grant process or grantee of a state agency. Organizational conflicts of interest occur when:

- A grantee's objectivity in carrying out the grant is impaired or compromised due to competing duties or loyalties
- A grantee, potential grantee or grant applicant has an unfair competitive advantage through being furnished unauthorized proprietary information or source selection information that is not available to all competitors

This section to be completed by Grantee’s Authorized Representative (AR):

I certify that we will maintain an adequate Conflict of Interest Policy, and throughout the term of our agreement, we will monitor and report any actual, potential, individual, or organizational conflicts of interest to the State’s Authorized Representative.

I also certify that I have read and understand the description of conflict of interest above and as of this date (check one of the two boxes below):

- I do not have any conflicts of interest relating to this project.
- I have an actual, potential, individual, or organizational (*indicate below*) conflict of interest. The nature of the conflict is as follows:

If at any time during the grant project I discover a conflict of interest, I will disclose that conflict immediately to the State’s Authorized Representative.

Grantee AR’s Printed Name: tyler cowing Date: _____

Grantee AR’s Signature: _____

Organization Name: _____

Project Name: _____

Legal Citation: ML_____, Chapter _____, Article ____, Section ____, Subdivision _____

State AR’s Printed Name: _____ Date: _____

State AR’s Signature: _____



Fairmont City Council
June 26, 2023

Agenda Item: 10.2

From: Matthew York, Director of Public Works/Utilities
To: Mayor and City Council

Subject: Repairs to Gomsrud Channel Wall

Policy/Action Requested:

Vote Required: X Simple Majority _____ Roll Call

Recommendation: Approval of Task Order #2 for the repairs to the Gomsrud Channel Wall

Overview:

On November 14, 2022, the City of Fairmont entered into a Master Agreement for Professional Services with Bolton & Menk. This Master Agreement was initiated due to the City Engineer position being vacated.

On May 18, 2023, former City Administrator, Cathy Reynolds, received a letter from Bolton & Menk discussing the Gomsrud channel wall and more directly the Gabion Baskets in the middle of the channel. The letter is attached to this agenda item, but the highlights are as follows:

- 1) There are failing portions on the West Side of the channel where rocks are failing out the gabion baskets.
- 2) They were initially installed in the 1990s.
- 3) Portions of the gabion basket wall have already been removed, and sheet piling has been put in their place.
- 4) The wall cannot be repaired with gabion baskets.

The conclusion and recommendations section states that the gabion baskets need to be removed and replaced with sheet pile walls designed to last 75+ years instead of 25-30 years in the gabion baskets. Cost is estimated at \$300-335,000 with an additional \$100,000 in removal and other expenses.

Budget Impact:

In the 2023 Capital Improvement Plan, the City has appropriated \$1,375,000 for the phase 1 projects at Gomsrud park. The cost of this project would be utilized out of those funds, and additional monies will be requested in 2024 to complete the project.

This project will delay the Gomsrud Park Project. This is due to the equipment needed to complete the project and wanting to avoid damaging the newly laid parking lots.

Attachments:

- Task Order #2
- Letter from Bolton & Menk dated 5-18-2023
- Map of the Channel and the Phase 1 Project Scope

.....
Council Action: _____

Date: _____

**CITY OF FAIRMONT, MN AND BOLTON & MENK, INC.
TASK ORDER TO AGREEMENT FOR PROFESSIONAL SERVICES**

TASK ORDER NO: 2 – Gomsrud Channel Wall Repairs

CLIENT: City of Fairmont, MN

CONSULTANT: Bolton & Menk, Inc.

DATE OF THIS TASK ORDER: June 26, 2023

DATE OF MASTER AGREEMENT FOR PROFESSIONAL SERVICES: November 14, 2022

Whereas, CLIENT and CONSULTANT entered into a Master Agreement for Professional Services (“Master Agreement”) as dated above; and CONSULTANT agrees to perform and complete the following Services for CLIENT in accordance with this Task Order and the terms and conditions of the Master Agreement. CLIENT and CONSULTANT agree as follows:

1.0 Scope of Services:

CONSULTANT shall perform the Services listed below or in the attached Exhibit I. All terms and conditions of the Master Agreement are incorporated by reference in this Task Order, except as explicitly modified in writing herein.

2.0 Fees:

CLIENT shall pay CONSULTANT in accordance with Section III of the Master Agreement and as follows:

TASK	DESCRIPTION	Total Cost
1	Project Administration & Coordination	\$4,900
2	Field Data Collection	\$2,800
3	Final Design and Construction Plans	\$18,500
4	Bidding Services	\$8,800
TOTAL (Fixed Fee)		\$35,000

The total fee through bidding shall be a fixed fee of \$35,000.

3.0 Schedule:

Schedule for performance of Services will be as follows or as set forth in attached Exhibit I, such that all services will be completed by December 31, 2024.

June 2023	• Authorization of professional services
July-August 2023	• Construction Plan development
September 2023	• Bidding and Contract approvals
October-December 2023	• Construction
May-June 2024	• Site Restoration

4.0 Deliverables

Deliverables will be as follows or as set forth in the attached Exhibit I.

5.0 Term

In the event that the Schedule for this Task Order extends beyond the term of the Master Agreement, either intentionally or unintentionally by Task Order Scope or by Task Order extension, then this Task Order shall operate to extend the Master Agreement through the completion of CONSULTANT’S obligations under this Task Order or until a new Master Agreement is executed incorporating this Task Order.

6.0 Other Matters

None

7.0 Project Managers

Project managers and contact information for the CLIENT and CONSULTANT for this Task Order, if different than the Master Agreement, are as follows:

CLIENT:
Matthew York
100 Downtown Plaza
Fairmont, Minnesota 56031
Office Phone: 507-238-3942
Email: myork@fairmont.org

BOLTON & MENK, INC.
Wesley W. Brown, P.E.
1501 S. State Street, Suite 100
Fairmont, MN 56031
Office Phone: 507-238-4738
Email: wesley.brown@bolton-menk.com

CLIENT: CITY OF FAIRMONT, MN

CONSULTANT: BOLTON & MENK, INC.

By: _____

By: Wesley W. Brown

Printed Name: _____

Printed Name: Wesley W. Brown, P.E.

Title: _____

Title: Senior Principal Engineer

ATTACHMENTS TO THIS TASK ORDER:
Exhibit I – Consultant’s Services

EXHIBIT I – CONSULTANT’S SERVICES (TASK ORDER 2)

GOMSRUD CHANNEL WALL REPAIRS

CITY OF FAIRMONT, MINNESOTA

DESCRIPTION OF PROJECT AND SCOPE OF IMPROVEMENTS

The CONSULTANT agrees to provide civil design engineering services required for the construction of the Gomsrud Channel Wall Repairs. The work is proposed on the west side of the existing channel to repair the failing gabion baskets and to prevent further movement of the existing structure.

The basic improvements anticipated as part of this Agreement include:

Construction of a steel sheet pile wall along the west side of the existing channel. The new wall would begin at the corner of the existing sheet pile on the north end of the channel and run approximately 350 feet south where it would match into the existing bridge abutment. It is anticipated that the wall would be constructed of galvanized steel with a pile cap to match the existing wall on the north end of the channel. The alignment would begin east of the existing gabion baskets on the north end and then cross-over and run west of the baskets for most of the project length. The existing gabion baskets would be removed and disposed of after the new sheet pile wall is installed. It is assumed that the channel will not need to be drained but will require intermittent closures to accommodate construction. Removing the existing gabion baskets from the west side of the channel is anticipated to be the most cost-effective alternative. Currently, the city does not have direct access to the west side of the channel and will need to assist in coordination of temporary access to the proposed construction area.

I.A. BASIC SERVICES

For purposes of this Project, Basic Services to be provided by the CONSULTANT are as follows:

Task 1: Project Administration and Coordination

CONSULTANT will meet with CLIENT to review available information relative to the project, confirm CLIENT design standards for the project, and verify the project scope & schedule.

CONSULTANT will offer regular updates on next steps and upcoming project requirements.

CONSULTANT will also prepare and provide miscellaneous project correspondence, scheduling, invoicing, and budget management necessary for expediting work products and project decision-making. Schedule updates will be provided on a regular basis.

Task 2: Field Data Collection

CONSULTANT will complete a topographic survey to provide base mapping, a digital terrain model, and utility information within the project site. Utility coordination will be completed to include private utility information on the topographic survey. CLIENT will provide documentation for boundary lines and right-of-way to be identified and accurately represented on the plans.

Task 3: Final Design and Construction Plans

CONSULTANT will perform structural calculations for the proposed sheet pile wall structure and prepare detailed construction plans for the proposed improvements. This includes preparation of applicable plan sections including:

- Title Sheet, Existing Conditions and Utilities
- Removal Plan
- Site Layout and Wall Alignment
- Site and Structural Details
- Statement of Estimated Quantities
- SWPPP/Erosion Control Plan
- Site Restoration and Turf Establishment Plan

CONSULTANT will prepare an engineer's cost estimate based on the final plans. CONSULTANT will prepare permit applications associated with the improvements and submit them for approval. The permit application fees will be the responsibility of the CLIENT. The following applications may be required:

- City of Fairmont – Land Disturbance Permit
- Minnesota Department of Natural Resources – Public Waters Work Permit

Task 4: Bidding Services

The CONSULTANT will prepare a complete project manual to include specifications and contract documents. CONSULTANT will prepare and publish the advertisement for bid and distribute the bid documents. CONSULTANT will provide responses to questions from contractors and issue addenda as required. CONSULTANT will attend the bid opening, prepare the resultant bid tabulation, and provide verification of submitted bids to CLIENT. CONSULTANT will prepare a contract award recommendation letter and attend the council meeting in which awarding of the contract is anticipated. CONSULTANT will distribute the contract to the selected contractor and secure the required contractor submittals necessary to commence construction.

Construction Engineering Services

CONSULTANT proposes an estimated hourly fee for construction-related services. CONSULTANT will provide a proposal with construction fee and summary of these services after bids are received to provide a well-defined scope and schedule. Construction services are not included within this agreement.

I.B. ADDITIONAL SERVICES

Consulting services performed other than those authorized under Section 1.A shall be considered not part of Basic Services and may be authorized by the CLIENT as Additional Services. Additional Services consist of those services that are not generally considered to be Basic Services; or exceed the requirements of the Basic Services; or are not definable prior to the bidding of the project.

Additional services may include:

1. Professional services associated with easement and property acquisition.
2. Professional services associated with wetland delineation.
3. Professional services associated with geotechnical investigation.
4. Professional services associated with public or private utility design and construction.
5. Professional services associated with construction administration, staking, and engineering.



**BOLTON
& MENK**

Real People. Real Solutions.

12224 Nicollet Avenue
Burnsville, MN 55337-1649

Ph: (952) 890-0509
Fax: (952) 890-8065
Bolton-Menk.com

May 18, 2023

Cathy Reynolds
City Administrator – City of Fairmont
100 Downtown Plaza
Fairmont, MN 56031

RE: Gomsrud Park Channel
Gabion Retaining Wall Opinion

Dear Cathy,

Below is an opinion summary based upon our review of the existing gabion retaining wall and the information provided.

I. BACKGROUND

Bolton & Menk, Inc. (BMI) has reviewed the condition of the existing gabion style retaining wall for the channel near Gomsrud park in Fairmont, MN. The conditions were noted by others to be in the process of failing with reports of rocks falling out of gabion baskets and towards the middle of the channel. The failing portion of the wall is on the west side of the channel. The east side appears to be mostly intact at the moment. The wall on the west side of the channel was built in the 1990's and a steel sheet pile wall was later added at the north and south ends.

II. DESCRIPTION OF WALL CONDITION

The main construction of the channel retaining wall is a gabion basket style wall. The baskets are constructed with galvanized steel wire and each basket is filled with rocks. The baskets get wider as they go down in elevation into the channel. There is evidence that the top of wall has moved in towards the middle of the channel and the soil behind the wall has moved with the top of wall. This is evident by the observed openings/cracks in the soil in some locations and the leaning appearance along the full length of the wall. It is not known how far the wall has moved from its original position, but it will continue to move until remediation measures are taken.

There is some visible damage to the wire that makes up the baskets and this appears to be caused by corrosion. This may be due to the proximity of a parking lot and the winter snow possibly containing salt that piles up near the wall when the lot is cleared. The openings in the wire baskets have allowed rocks to fall out of the baskets and into the channel which will accelerate the deterioration of the wall and will also cause issues with boat traffic in the channel.

III. CONCLUSION/RECOMMENDATIONS

The condition of the gabion wall on the west side of the channel is likely not repairable and would require the channel to be drained to fully evaluate or repair. That would only be a short-term

solution with the need for a complete replacement in the near future. While it is possible to replace the gabion wall with a new wall of the same style, this is likely not a viable option as it's not the most economical and beneficial solution for long term results. Replacement of the wall with a gabion style wall would likely require shutting down and completely draining the channel to provide access to remove and replace the wall. The relative life span (approx. 25-30 years) of this type of wall is shorter than other types of retaining walls.

It is recommended that the existing channel wall on the west side be replaced with a steel sheet pile wall. There are already existing portions of the wall that are now sheet pile (near the bridge and on the north end of the channel) that can be matched. It might be possible to install a sheet pile wall with little disturbance to the channel and reduced down time. The sheet pile wall could be installed behind the existing gabion wall in some areas and then the gabion baskets could be removed after the new wall is in place which would also widen the channel in this area. Alternatively, the sheet pile wall could be installed on the channel side of the existing gabion walls and that material could be left in place. This option would actually narrow the channel slightly and could create a transitional challenge at the bridge underpass. Access to the west side of the channel would be the most efficient way to remove the existing walls and install a new sheet pile wall. This would require access to private property lots and residential properties.

The sheet pile wall will be designed for a longer overall life span than the gabion style wall. Typically, we can design a sheet pile wall to get 75+ years of design life versus the 25-30 years of a submerged gabion wall. The estimated cost for a sheet pile wall would be about \$850-\$950 per foot of wall. At 350 feet the cost would be around \$300,000 - \$335,000 to install the sheet pile wall with some added costs estimated at \$100,000 to remove the existing wall. There may also be some additional costs for access to private property during construction and will likely require several permits from state and federal agencies.

Sincerely,
Bolton & Menk, Inc.



Jason Graham, P.E.
Structural Project Engineer

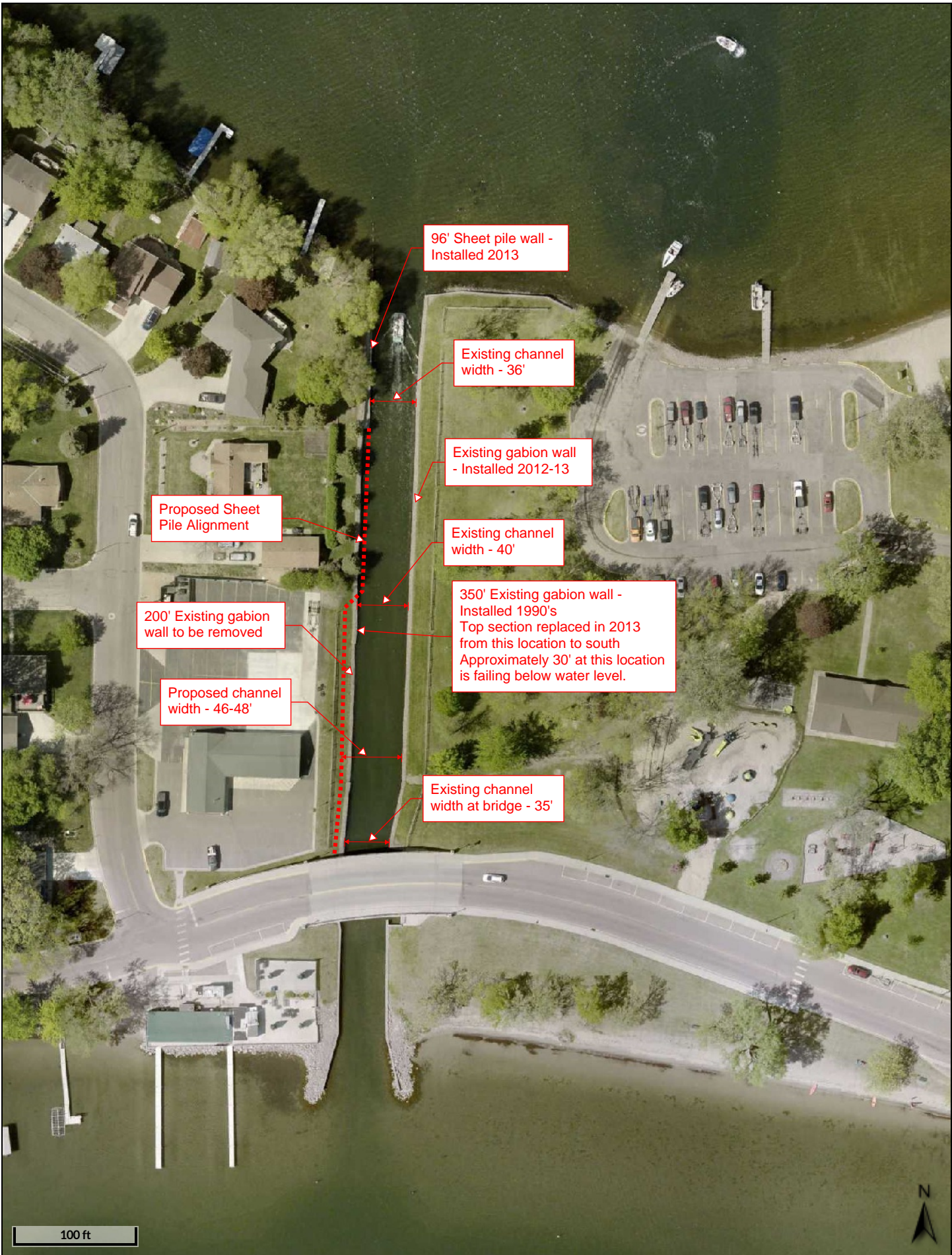

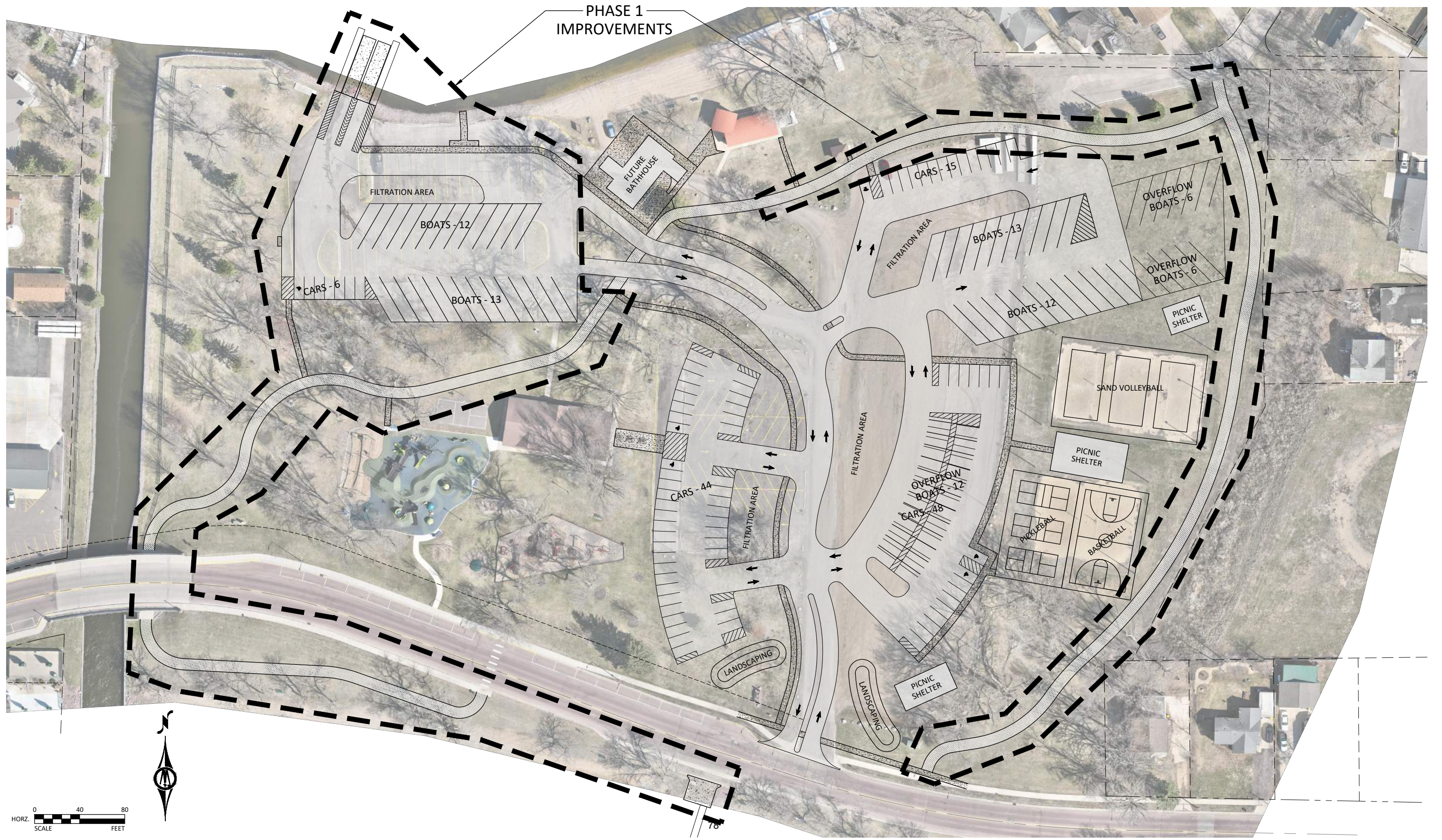

H:\FAIR\01130113\CAD\C3D\MISC-130113-ConceptE.dwg 6/21/2023 11:35:14 AM





Fairmont City Council
June 26, 2023

Agenda Item: 10.3

From: Peter Bode, Planner & Zoning Official
To: Mayor and City Council

Subject: Preliminary and Final Plat for Fairmont Industrial Park Twelfth Addition

Policy/Action Requested: Adoption of Resolution 2023-24.

Vote Required: Simple Majority Roll Call

Recommendation: The Planning Commission recommends approval of the Fairmont Industrial Park Twelfth Addition.

Overview: Fairmont Growth & Opportunity has proposed to subdivide their current parcel at 700 South Armstrong Drive. The plat would extend South Armstrong Drive south through the parcel and create a new lot in the east of the parcel. Midwest Shop Condos, LLC, intends to purchase the new parcel and place a Planned Unit Development (PUD) for industrial condominiums.

The proposed plat meets the requirements of City Code relating to parcel dimension and street design.

To approve the plat, Council may adopt Resolution 2023-24.

Budget Impact: Road and utility maintenance for any extension of South Armstrong Drive. Likely maintenance for the stormwater retention pond.

- Attachments:**
- (1) Resolution 2023-24
 - (3) Preliminary and Final Plat
 - (4) Satellite photo of the area
 - (5) Planning Commission Resolution 2023-2

Council Action: _____ Date: _____

CITY OF FAIRMONT, MN
CITY COUNCIL RESOLUTION 2023-24

APPROVAL OF THE PRELIMINARY AND FINAL PLAT OF THE FAIRMONT
INDUSTRIAL PARK TWELFTH ADDITION

WHEREAS, Fairmont Growth Opportunities Corporation, a Minnesota Nonprofit Corporation, (“Applicant”) has submitted an application for Preliminary Plat approval for the Fairmont Industrial Park Twelfth Addition, located at 700 Armstrong Drive S, Fairmont, MN 56031 and legally described in Exhibit A and depicted in Exhibit B which are attached hereto and incorporated herein by reference; and

WHEREAS, the Applicant is the owner of the above-described Property; and

WHEREAS, pursuant to Fairmont City Code, Section 24-77, preliminary plats shall be prepared by a surveyor and contain the following information:

- (1) Name of proposed plat, name and address of the owners, registered engineer or surveyor, and owners of the adjacent property.
- (2) Legal description of the property to be platted and small scale sketch showing location as described.
- (3) Date, approximate north point, and graphic scale (not less than one hundred (100) feet to one (1) inch).
- (4) Acreage of the land to be subdivided.
- (5) Zoning classification of land to be subdivided and all adjacent lands.
- (6) Contours at an interval of two (2) feet. If natural contours are to be changed more than two (2) feet a grading plan should be submitted showing approximate final elevations.
- (7) Boundary lines of area to be subdivided, their bearings and distances.
- (8) Existing and proposed easements and their locations, widths and distances.
- (9) Streets on and adjacent to the tract and their names, widths, proposed approximate grades and proposed relative ground elevations at the intersections of all streets and every one hundred (100) feet along such streets and at the corners or extremities of the plat, and other dimensions as may be required. Elevations shall be to city datum or if unavailable a bench mark for the plat shall be shown.
- (10) Utilities on and adjacent to the tract showing proposed connections to existing utility systems. Rear easements for utility poles and wires shall be provided wherever possible. Data to be provided includes type of utility; location of manholes, catch basins, hydrants, etc.; approximate depth of pipes, size of pipe and direction of flow.
- (11) Lot lines, lot numbers, lot dimensions and square footage of each lot.
- (12) Sites and their acreages, if any to be reserved or dedicated for parks, recreation areas, open spaces, schools or other public uses.
- (13) Minimum building setback lines.

- (14) Location of railroads, streams, natural and proposed drainage courses, permanent buildings, natural features, and other information.
- (15) Other reasonable information, such as percolation and other soil tests, if so requested by the city planner or planning commission.
- (16) Description of any proposed deed restrictions.
- (17) An informational statement as to the general plan of improvement, drainage, and development.

WHEREAS, pursuant to Fairmont City Code, Section 24-82(a), the final plat shall include the following information or any other information as required by state law:

- (1) Data required by state law to fully describe the land to be platted including accurate dimensions, angles, bearings to describe boundaries, streets, easements, areas reserved for public purpose and other important features (drawn not less than one hundred (100) feet to one (1) inch).
- (2) Name and right-of-way width of each street.
- (3) Block and lot numbers, lot dimensions and square footage.
- (4) Purpose for which sites, other than residential lots, are dedicated or reserved.
- (5) Location of rivers, streams, creeks, lakes and wetlands as required by state law.
- (6) Names and location of adjoining subdivisions, streets, right-of-ways, and any other sites for public use.
- (7) Certifications on the plats that are required by state law.
- (8) Dedication of streets, easements, public areas and right-of-ways.

WHEREAS, pursuant to Fairmont City Code, Section 24-82(b) the subdivider shall submit the following when filing the final plat unless exempted by the city planner:

- (1) Certification that the subdivider has complied with one (1) of the following alternatives:
 - a. Has installed and constructed basic improvements in the proposed subdivision in compliance with the requirements of this chapter.
 - b. Executed an agreement with the city council regarding the installation and construction of basic improvements in the proposed subdivision.
- (2) Cross-sections, profiles and grades of streets, curbs, gutters and sidewalks showing locations of in-street utilities; drawn to standard scales and elevations and prepared by a registered professional engineer.
- (3) Drainage and grading plan showing approximate final elevations at two-foot intervals.
- (4) Protective covenant documents.
- (5) Letters of approval of highway access points and service roads from the commissioner of highways and county engineer.
- (6) Title opinion by an attorney indicating ownership of the subdivision when public easements or right-of-ways are dedicated to the city.
- (7) Tax certification showing that all taxes and assessments due on the property

to be subdivided have been paid in full.

WHEREAS, pursuant to Fairmont City Code, Section 24-93(b), the Planning Commission shall consider the final plat and will not recommend the plat for approval unless it meets the following:

- (1) Conforms to the preliminary plat.
- (2) Conforms to design standards set forth in this chapter.
- (3) Conforms to the comprehensive plan.
- (4) Is in accordance with all requirements and laws of the state.

WHEREAS, the Fairmont Planning Commission considered the Applicant's request for a Preliminary Plat at a duly noticed Public Hearing, which took place on June 6, 2023, and recommended approval to the City Council; and

WHEREAS, a Development Agreement is required and shall be prepared between the City of Fairmont and Fairmont Growth Opportunities Corporation, which outlines the responsibilities of Fairmont Growth Opportunities Corporation to install the required street and infrastructure improvements necessary to support development on lots within the Fairmont Industrial Park Twelfth Addition subdivision; and

WHEREAS, the City Council of the City of Fairmont has reviewed the Preliminary and Final Plat of the Fairmont Industrial Park Twelfth Addition for compliance with Fairmont City Code, and statutes of the State of Minnesota.

NOW, THEREFORE, BE IT RESOLVED BY THE CITY COUNCIL THAT, the City Council hereby adopts the Findings of Fact of the Planning Commission and the Preliminary and Final Plat of the Fairmont Industrial Park Twelfth Addition are hereby approved, subject to the following conditions:

1. The Preliminary and Final Plat shall comply with the provisions of all state statutes and standard procedures for platting in Martin County.
2. Prior to the City's execution of the Final Plat, the Applicant must enter into an agreement with the City for the installation of all required improvements, which shall be referred to as the "Development Agreement" and the Applicant shall provide the required security contained therein.
3. The requirements and conditions of the Development Agreement shall be incorporated as conditions of the City's execution of the Final Plat.
4. In accordance with Fairmont City Code, Section 24-93(d), the Final Plat shall be recorded by the subdivider within 90 days of approval or the City's approval shall be deemed null and void without further action by the City Council following the expiration of such period, unless a written request for extension has been made by the Applicant stating the reasons

why an extension is necessary and approved by the City Council.

5. The Applicant shall pay all fees, including by not limited to recording fees.

PASSED by the City Council of the City of Fairmont on this 26th day of June, 2023.

ATTEST

City Clerk

Mayor

EXHIBIT A

Legal Description of Property Being Platted

LEGAL DESCRIPTION

That part of the Northeast Quarter of the Northwest Quarter of Section 12, Township 102 North, Range 31 West, City of Fairmont, Martin County, Minnesota, described as follows:

Beginning at the Southwest corner of Fairmont Industrial Park Seventh Addition, according to the recorded plat thereof; thence on an assumed bearing of South 88 degrees 23 minutes 50 seconds East, along the south line of said plat, a distance of 633.00 feet to the Southeast corner of said plat located on the east line of the Northwest Quarter of said section; thence South 0 degrees 19 minutes 07 seconds West, along said east line, a distance of 917.96 feet to the Southeast corner of the Northeast Quarter of the Northwest Quarter of said section; thence North 88 degrees 23 minutes 26 seconds West, along the south line of said Northeast Quarter of the Northwest Quarter, a distance of 699.00 feet; thence North 0 degrees 19 minutes 07 seconds East a distance of 741.90 feet to the Southwest corner of South Armstrong Drive as platted in the Plat of Fairmont Industrial Park Eleventh Addition, according to the recorded plat thereof; thence South 88 degrees 23 minutes 50 seconds East, along the south line of said South Armstrong Drive, a distance of 66.00 feet to the Southeast corner of said South Armstrong Drive; thence North 0 degrees 19 minutes 07 seconds East, along the east line of said South Armstrong Drive, a distance of 175.98 feet to the point of beginning, containing 14.46 acres, subject to easements now of record in said county and state.

EXHIBIT B

Depiction of Preliminary and Final Plat

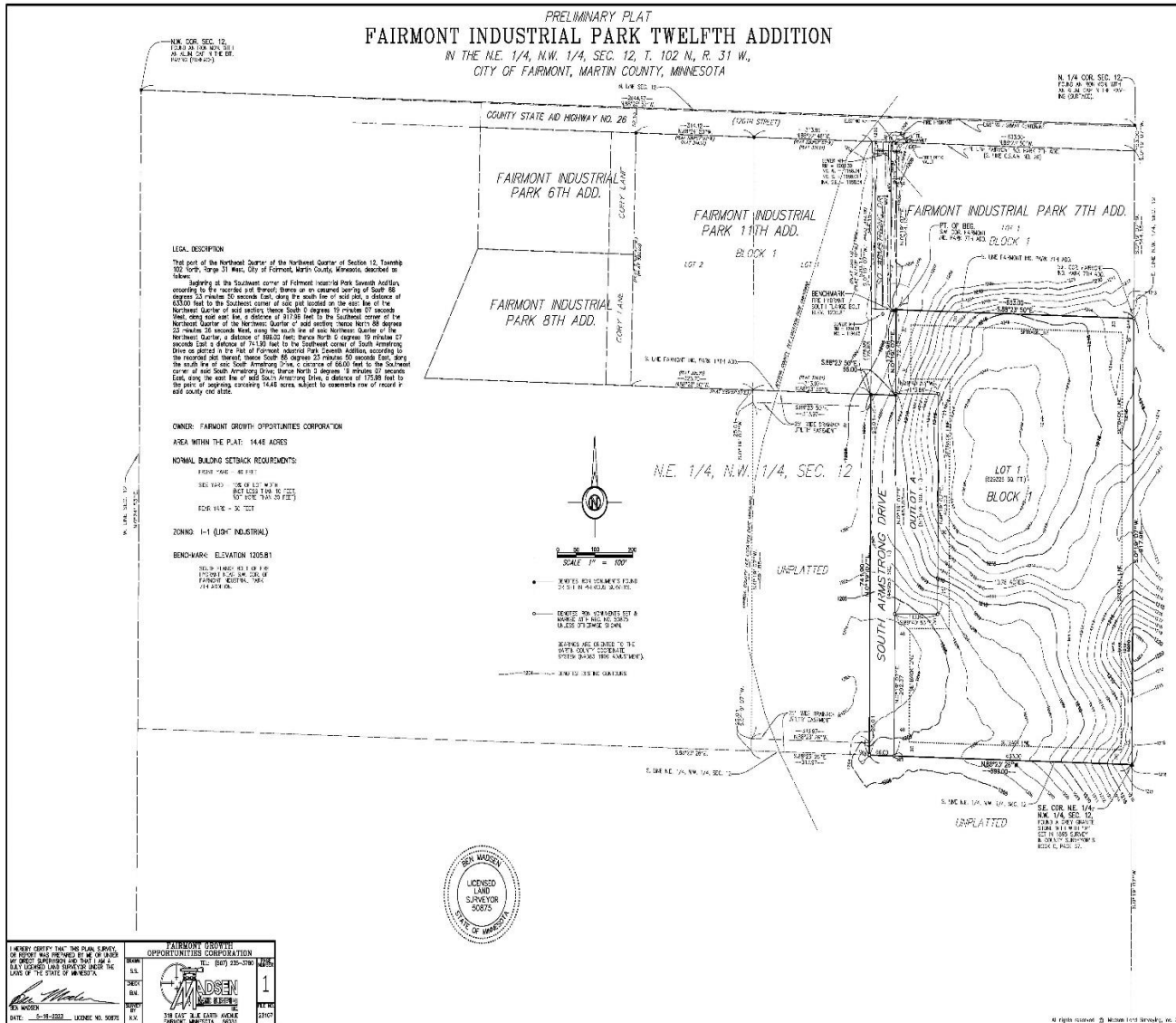

FAIRMONT INDUSTRIAL PARK TWELFTH ADDITION

IN THE NE. 1/4, N.W. 1/4, SEC. 12, T. 102 N., R. 31 W.,
CITY OF FAIRMONT, MARTIN COUNTY, MINNESOTA

N.W. COR. SEC. 12,
T. 102 N., R. 31 W.,
S. 1/4, SEC. 12,
T. 102 N., R. 31 W.

N. 1/4 COR. SEC. 12,
T. 102 N., R. 31 W.,
S. 1/4, SEC. 12,
T. 102 N., R. 31 W.

INSTRUMENT OF DEDICATION

KNOW ALL MEN BY THESE PRESENTS: That Fairmont Growth Opportunities, a Minnesota Corporation, owner and proprietor of the following described property situated in the City of Fairmont, County of Martin, State of Minnesota, to wit:

That part of the Northeast Quarter of the Northeast Quarter of Section 12, Township 102 North, Range 31 West, City of Fairmont, Martin County, Minnesota, described as follows:

Beginning at the Southwest corner of Fairmont Industrial Park Seventh Addition, according to the recorded plat thereof; thence on an assumed bearing of South 88 degrees 23 minutes 20 seconds East, along the south line of said plat, a distance of 533.00 feet to the southeast corner of said plat located on the east line of the Northwest Quarter of said section; thence South 0 degrees 19 minutes 07 seconds East, along said east line, a distance of 877.00 feet to the southeast corner of the Northwest Quarter of the Northeast Quarter of said section; thence North 88 degrees 23 minutes 20 seconds West, along the south line of said Northwest Quarter of the Northeast Quarter, a distance of 588.00 feet; thence North 0 degrees 19 minutes 07 seconds East, a distance of 341.00 feet to the Southeast corner of South Armstrong Drive as platred in the Plat of Fairmont Industrial Park Seventh Addition, according to the recorded plat thereof; thence South 88 degrees 23 minutes 20 seconds East, along the south line of said South Armstrong Drive, a distance of 86.00 feet to the Southeast corner of said South Armstrong Drive; thence North 0 degrees 19 minutes 07 seconds East, along the east line of said South Armstrong Drive, a distance of 170.00 feet to the point of beginning, containing 14.48 acres, subject to easements now of record in said county and state.

Has caused the same to be surveyed and plotted as FAIRMONT INDUSTRIAL PARK TWELFTH ADDITION.

In witness whereof Andrew Hal, President and Sara Pierce, Secretary/Treasurer, have set our hands, on behalf of Fairmont Growth Opportunities, a Minnesota Corporation, this _____ day of _____, 2023.

Andrew Hal, President
Sara Pierce, Secretary/Treasurer

STATE OF MINNESOTA
COUNTY OF MARTIN

The foregoing Instrument of dedication was acknowledged before me this _____ day of _____, 2023, by Andrew Hal, President and Sara Pierce, Secretary/Treasurer, on behalf of Fairmont Growth Opportunities, a Minnesota Corporation.

Notary Public, Martin County, Minnesota
My commission expires _____

SURVEYORS CERTIFICATE

I hereby certify that I have surveyed and defined the property described on this plat as FAIRMONT INDUSTRIAL PARK TWELFTH ADDITION, that this plat is a correct representation of the survey; that all distances are correctly shown on the plat in feet and hundredths of a foot; that all monuments have been correctly placed in the ground so shown; that the public boundaries have been correctly designated on the plat and that there are no wet lands as defined in NE SEC. 502, Stat. 1, or public highways to be designated other than as shown.

Ben Madson, Land Surveyor
Minnesota Registration No. 50875

SURVEYORS ACKNOWLEDGMENT

STATE OF MINNESOTA
COUNTY OF MARTIN

The foregoing Surveyors Certificate was acknowledged before me this _____ day of _____, 2023, by Ben Madson, Land Surveyor.

Notary Public, Martin County, Minnesota
My Commission expires _____

CITY OF FAIRMONT
We do hereby certify that on this _____ day of _____, 2023, the City Council of Fairmont, Minnesota, approved this plat.

City Clerk
Mayor

CITY PLANNING COMMISSION APPROVAL
Be it known that on the _____ day of _____, 2023, the Planning Commission of the City of Fairmont, Martin County, Minnesota, did duly approve this plat of ORDINANCE SUBDIVISION.

Chairperson of the Planning Commission

MARTIN COUNTY AUDITORS TAX STATEMENT
I hereby certify that there are no delinquent taxes and the transfer has been entered on the _____ day of _____, 2023.

Martin County Auditor

MARTIN COUNTY TREASURER
I hereby certify that the current years taxes have been paid in full. Certified on the _____ day of _____, 2023.

Martin County Treasurer

MARTIN COUNTY RECORDER
I hereby certify that this instrument was filed in the Office of the County Recorder for records on the _____ day of _____, 2023, at _____ o'clock _____ AM, was duly recorded in Envelope Number _____ and recorded as Document Number _____.

Martin County Recorder



SCALE IN FEET
0 50 100 200

POINTS FROM VOLUNTARY ROAD OR SECTION CORNERS.

POINTS FROM MONUMENTS SET & MARKED WITH IRON OR STEEL OR BRASS OR WOODEN STAKES.

BEARING ALL POINTS TO THE MARTIN COUNTY GEODETIC SYSTEM (WGS84 - 560 345 000 000).



S.E. COR. N.E. 1/4,
N.W. 1/4, SEC. 12,
T. 102 N., R. 31 W.,
S. 1/4, SEC. 12,
T. 102 N., R. 31 W.

All rights reserved © Tucker Land Surveying Inc. 2302

PRELIMINARY PLAT
FAIRMONT INDUSTRIAL PARK TWELFTH ADDITION
 IN THE N.E. 1/4, N.W. 1/4, SEC. 12, T. 102 N., R. 31 W.,
 CITY OF FAIRMONT, MARTIN COUNTY, MINNESOTA

N.W. COR. SEC. 12,
 FOUND AN IRON MON. WITH
 AN ALUM. CAP IN THE BIT.
 PAVING (SURFACE).

N. 1/4 COR. SEC. 12,
 FOUND AN IRON MON. WITH
 AN ALUM. CAP IN THE PAV-
 ING (SURFACE).

LEGAL DESCRIPTION

That part of the Northeast Quarter of the Northwest Quarter of Section 12, Township 102 North, Range 31 West, City of Fairmont, Martin County, Minnesota, described as follows:
 Beginning at the Southwest corner of Fairmont Industrial Park Seventh Addition, according to the recorded plat thereof; thence on an assumed bearing of South 88 degrees 23 minutes 50 seconds East, along the south line of said plat, a distance of 633.00 feet to the Southeast corner of said plat located on the east line of the Northwest Quarter of said section; thence South 0 degrees 19 minutes 07 seconds West, along said east line, a distance of 917.96 feet to the Southeast corner of the Northeast Quarter of the Northwest Quarter of said section; thence North 88 degrees 23 minutes 26 seconds West, along the south line of said Northeast Quarter of the Northwest Quarter, a distance of 699.00 feet; thence North 0 degrees 19 minutes 07 seconds East a distance of 741.90 feet to the Southwest corner of South Armstrong Drive as platted in the Plat of Fairmont Industrial Park Eleventh Addition, according to the recorded plat thereof; thence South 88 degrees 23 minutes 50 seconds East, along the south line of said South Armstrong Drive, a distance of 66.00 feet to the Southeast corner of said South Armstrong Drive; thence North 0 degrees 19 minutes 07 seconds East, along the east line of said South Armstrong Drive, a distance of 175.98 feet to the point of beginning, containing 14.46 acres, subject to easements now of record in said county and state.

OWNER: FAIRMONT GROWTH OPPORTUNITIES CORPORATION

AREA WITHIN THE PLAT: 14.46 ACRES

NORMAL BUILDING SETBACK REQUIREMENTS:

- FRONT YARD - 40 FEET
- SIDE YARD - 10% OF LOT WIDTH
(NOT LESS THAN 10 FEET,
NOT MORE THAN 30 FEET)
- REAR YARD - 30 FEET

ZONING: I-1 (LIGHT INDUSTRIAL)

BENCHMARK: ELEVATION 1205.81

SOUTH FLANGE BOLT OF FIRE
 HYDRANT NEAR S.W. COR. OF
 FAIRMONT INDUSTRIAL PARK
 7TH ADDITION.

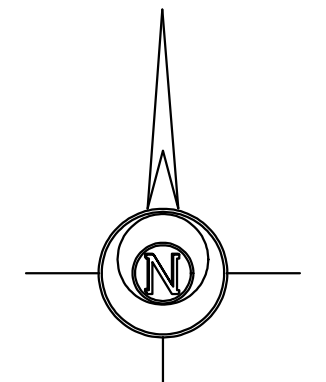
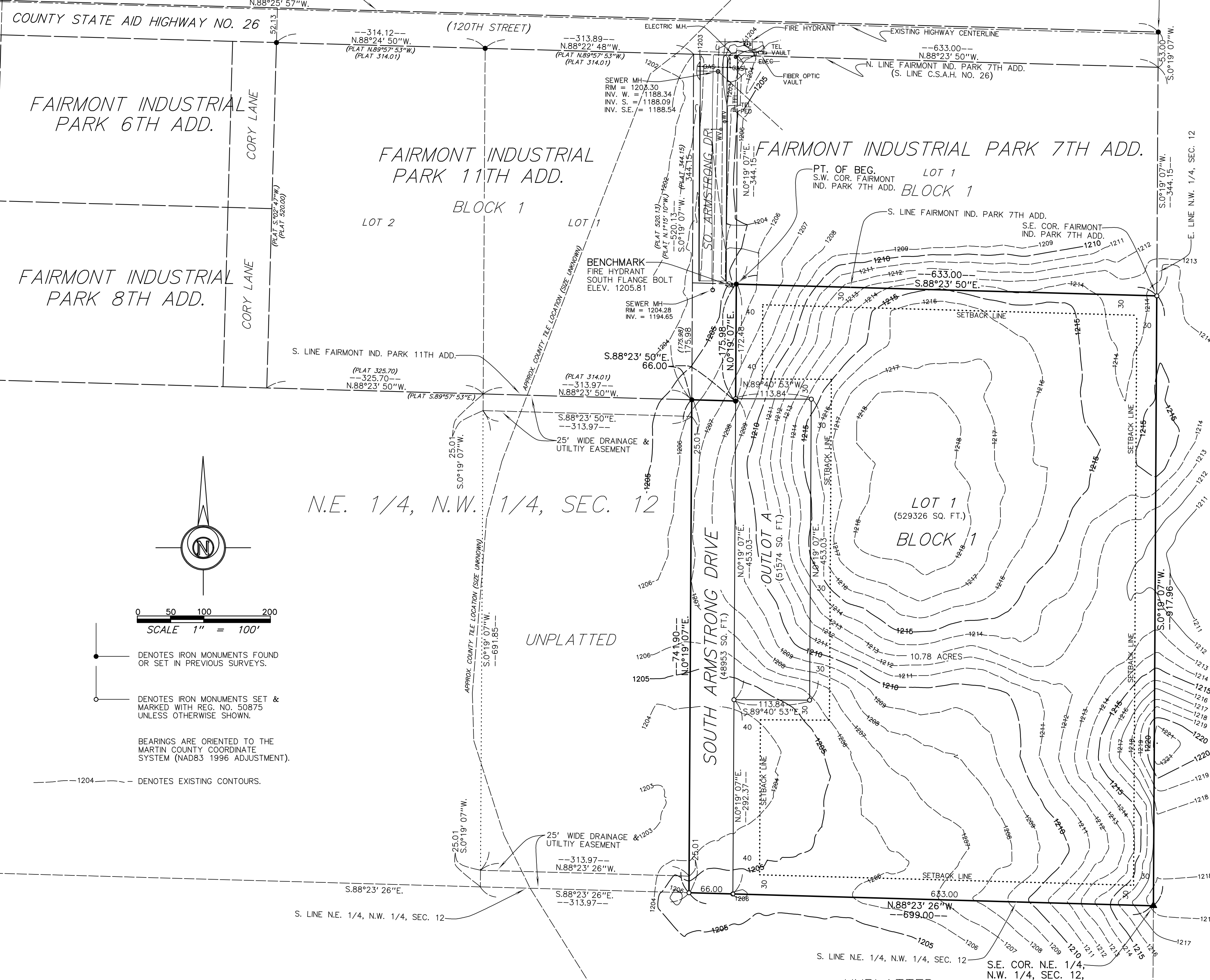

0 50 100 200
 SCALE 1" = 100'

- DENOTES IRON MONUMENTS FOUND OR SET IN PREVIOUS SURVEYS.
- DENOTES IRON MONUMENTS SET & MARKED WITH REG. NO. 50875 UNLESS OTHERWISE SHOWN.

BEARINGS ARE ORIENTED TO THE
 MARTIN COUNTY COORDINATE
 SYSTEM (NAD83 1996 ADJUSTMENT).

---1204--- DENOTES EXISTING CONTOURS.

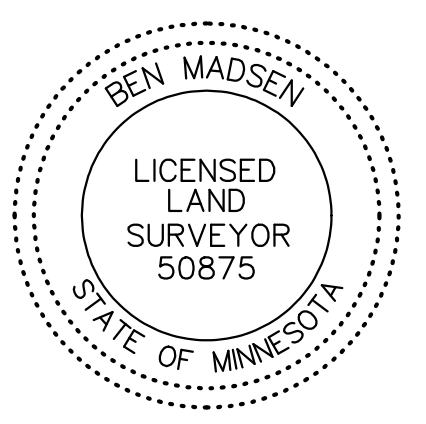

I HEREBY CERTIFY THAT THIS PLAN, SURVEY, OR REPORT WAS PREPARED BY ME OR UNDER MY DIRECT SUPERVISION AND THAT I AM A DULY LICENSED LAND SURVEYOR UNDER THE LAWS OF THE STATE OF MINNESOTA.		FAIRMONT GROWTH OPPORTUNITIES CORPORATION	
DRAWN S.S.	TEL: (507) 235-3780	PAGE NUMBER 1	
CHECK B.M.		FILE NO. 23107	
SURVEY BY K.V.	BEN MADSEN LAND SURVEYING INC. 318 EAST BLUE EARTH AVENUE FAIRMONT, MINNESOTA 56031		
DATE: 5-16-2023	LICENSE NO. 50875		

S.E. COR. N.E. 1/4,
 N.W. 1/4, SEC. 12,
 FOUND A GREY GRANITE
 STONE WITH WITH "X"
 SET IN 1895 SURVEYOR'S
 BOOK C, PAGE 67.

FAIRMONT INDUSTRIAL PARK TWELFTH ADDITION

IN THE N.E. 1/4, N.W. 1/4, SEC. 12, T. 102 N., R. 31 W.,
CITY OF FAIRMONT, MARTIN COUNTY, MINNESOTA

N.W. COR. SEC. 12,
FOUND AN IRON MON. WITH
AN ALUM. CAP IN THE BIT.
PAVING (SURFACE).

N. 1/4 COR. SEC. 12,
FOUND AN IRON MON. WITH
AN ALUM. CAP IN THE PAV-
ING (SURFACE).

INSTRUMENT OF DEDICATION

KNOW ALL MEN BY THESE PRESENTS: That Fairmont Growth Opportunities, a Minnesota Corporation, owner and proprietor of the following described property situated in the City of Fairmont, County of Martin, State of Minnesota, to wit:

That part of the Northeast Quarter of the Northwest Quarter of Section 12, Township 102 North, Range 31 West, City of Fairmont, Martin County, Minnesota, described as follows:

Beginning at the Southwest corner of Fairmont Industrial Park Seventh Addition, according to the recorded plat thereof; thence on an assumed bearing of South 88 degrees 23 minutes 50 seconds East, along the south line of said plat, a distance of 633.00 feet to the Southeast corner of said plat located on the east line of the Northwest Quarter of said section; thence South 0 degrees 19 minutes 07 seconds West, along said east line, a distance of 917.96 feet to the Southeast corner of the Northeast Quarter of the Northwest Quarter of said section; thence North 88 degrees 23 minutes 26 seconds West, along the south line of said Northeast Quarter of the Northwest Quarter, a distance of 699.00 feet; thence North 0 degrees 19 minutes 07 seconds East, a distance of 741.90 feet to the Southwest corner of South Armstrong Drive as platted in the Plat of Fairmont Industrial Park Eleventh Addition, according to the recorded plat thereof; thence South 88 degrees 23 minutes 50 seconds East along the south line of said South Armstrong Drive, a distance of 66.00 feet to the Southeast corner of said South Armstrong Drive; thence North 0 degrees 19 minutes 07 seconds East, along the east line of said South Armstrong Drive, a distance of 175.98 feet to the point of beginning, containing 14.46 acres, subject to easements now of record in said county and state.

Has caused the same to be surveyed and platted as FAIRMONT INDUSTRIAL PARK TWELFTH ADDITION.

In witness whereof Andrew Noll, President and Sara Pierce, Secretary/Treasurer, have set our hands, on behalf of Fairmont Growth Opportunities, a Minnesota Corporation, this _____ day of _____, 2023.

Andrew Noll, President Sara Pierce, Secretary/Treasurer

STATE OF MINNESOTA)
COUNTY OF MARTIN)

The foregoing instrument of dedication was acknowledged before me this _____ day of _____, 2023, by Andrew Noll, President and Sara Pierce, Secretary/Treasurer, on behalf of Fairmont Growth Opportunities, a Minnesota Corporation.

Notary Public, Martin County, Minnesota
My commission expires _____

SURVEYORS CERTIFICATE

I hereby certify that I have surveyed and platted the property described on this plat as FAIRMONT INDUSTRIAL PARK TWELFTH ADDITION, that this plat is a correct representation of the survey, that all distances are correctly shown on the plat in feet and hundredths of a foot, that all monuments have been correctly placed in the ground as shown; that the outside boundary lines are correctly designated on the plat and that there are no wet lands as defined in MS 505.02, Subd. 1, or public highways to be designated other than as shown.

Ben Madsen, Land Surveyor
Minnesota Registration No. 50875

SURVEYORS ACKNOWLEDGMENT

STATE OF MINNESOTA)
COUNTY OF MARTIN)

The foregoing Surveyors Certificate was acknowledged before me this _____ day of _____, 2023, by Ben Madsen, Land Surveyor.

Notary Public, Martin County, Minnesota
My Commission expires _____

CITY OF FAIRMONT

We do hereby certify that on this _____ day of _____, 2023, the City Council of Fairmont, Minnesota, approved this plat.

City Clerk Mayor

CITY PLANNING COMMISSION APPROVAL

Be it known that on the _____ day of _____, 2023, the Planning Commission of the City of Fairmont, Martin County, Minnesota, did duly approve this plat of GRONEWALD SUBDIVISION.

Chairperson of the Planning Commission

MARTIN COUNTY AUDITORS TAX STATEMENT

I hereby certify that there are no delinquent taxes and the transfer has been entered on the _____ day of _____, 2023.

Martin County Auditor

MARTIN COUNTY TREASURER

I hereby certify that the current years taxes have been paid in full. Certified on the _____ day of _____, 2023.

Martin County Treasurer

MARTIN COUNTY RECORDER

I hereby certify that this instrument was filed in the Office of the County Recorder for record on the _____ day of _____, 2023, at _____ o'clock _____ M., was duly recorded in Envelope Number _____ and recorded as Document Number _____.

Martin County Recorder

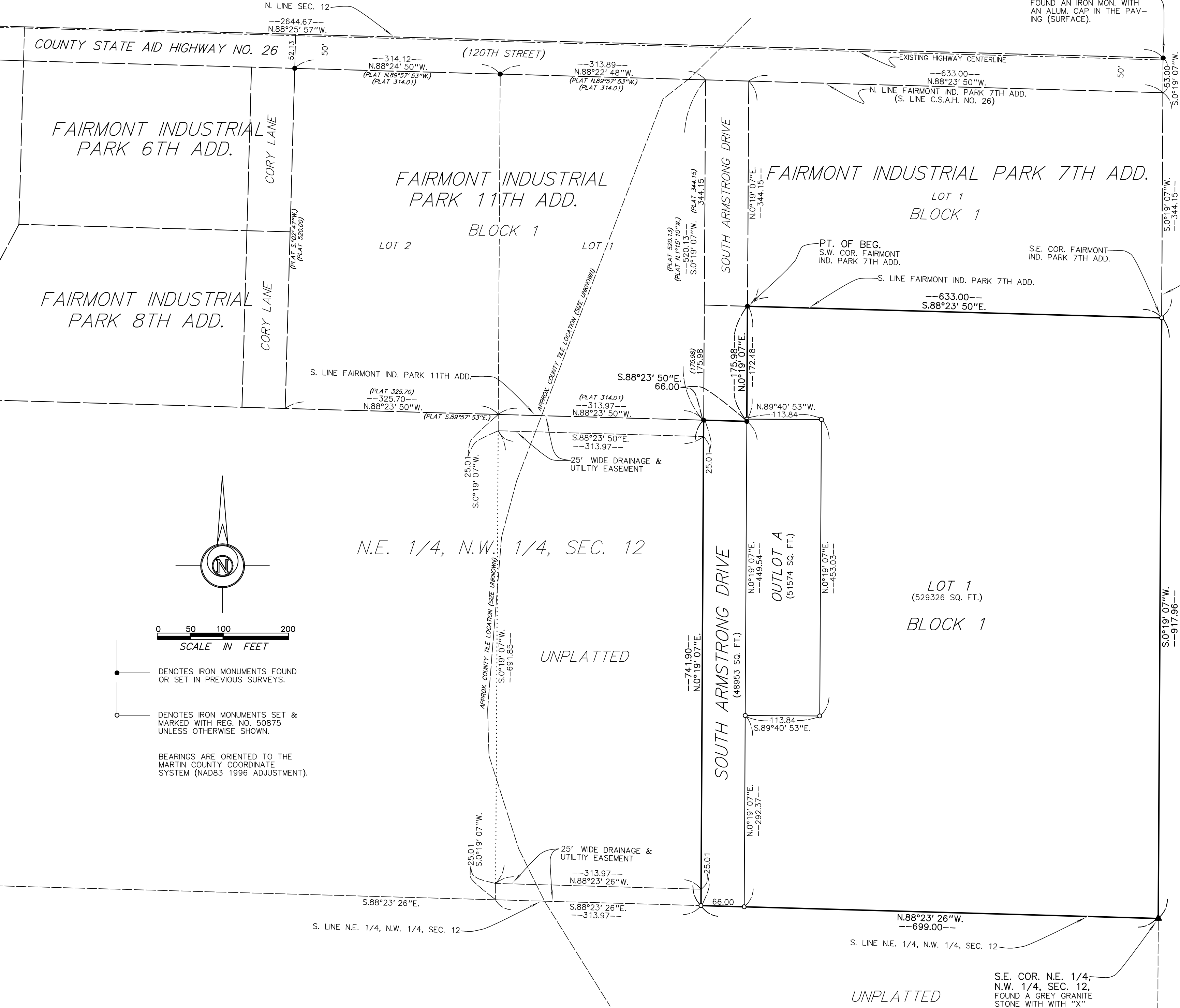

W. LINE SEC. 12
N.02°24'53"E.

S.01°19'07"W.

S.05°07'37"W.

S.05°07'37"W.

S.05°07'37"W.

S.05°07'37"W.

S.05°07'37"W.

S.05°07'37"W.

S.05°07'37"W.

S.05°07'37"W.

S.05°07'37"W.

S.05°07'37"W.



233030010

230390055

233280010

231070010

231060020

231060015

231060010

230390085

231110010

233390020

233390010

231120010

230390080

230390080



FAIRMONT GROWTH OPPTY CO
700 ARMSTRONG DR S
42.15 Acres Value \$455800 Note:

View: [Parcel Report](#) | [Soil Report](#) | [Pictometry Imagery](#)

**CITY OF FAIRMONT
PLANNING COMMISSION
RESOLUTION 2023-2**

**RECOMMENDING APPROVAL OF THE FAIRMONT INDUSTRIAL PARK TWELFTH ADDITION PRELIMINARY
AND FINAL PLAT**

Whereas, Fairmont Growth & Opportunity has proposed a preliminary and final plat for the Fairmont Industrial Park Twelfth Addition, and;

Whereas, City staff recommend the approval of the proposed preliminary and final plat, and;

Whereas, the Fairmont Planning Commission held a public hearing on the topic June 6, 2023.

Now therefore, be it resolved by the Fairmont Planning Commission that it makes the following findings of fact:

1. The proposed plat conforms to City Code Chapter 24 – Streets for design of rights-of-way and other public improvements.
2. The proposed plat conforms to City Code Chapter 26 – Zoning for lot design and land use.
3. The proposed plat meets the vision of the 2040 Comprehensive Plan for orderly development and is in accordance with all requirements and laws of the State of Minnesota.

Be it further resolved by the Fairmont Planning Commission that it recommends to Fairmont City Council that the proposed preliminary and final plats of the Fairmont Industrial Park Twelfth Addition be approved.

Passed and adopted by the Planning Commission of the City of Fairmont on this 6th day of June, 2023.



Tom Mesich, Chair



Fairmont City Council
June 26, 2023

Agenda Item: 10.4

From: Peter Bode, Planner & Zoning Official
To: Mayor and City Council

Subject: Planned Unit Development for Shop Condominiums at Lot 1, Block 1, Fairmont Industrial Park Twelfth Addition

Policy/Action Requested: Adoption of Resolution 2023-25.

Vote Required: X Simple Majority Roll Call

Recommendation: The Planning Commission recommends approval of the PUD with conditions.

Overview: Midwest Shop Condos has applied for a Planned Unit Development (PUD) to build shop condominiums at Lot 1 Block 1 of the Fairmont Industrial Park Twelfth Addition. The applicant proposes several buildings on the site. The buildings would be split into units and sold to individual owners under an overall governance structure pursuant to state statute for common interest developments. Allowable uses of the units would be any uses allowed in the underlying I-1 Light Industrial district; however most units are intended to be shops and storage for businesses and contractors.

The City's role in reviewing the proposal is to verify that the overall site design meets the purposes of the Comprehensive Plan and design standards set by City Code; and that the proposal would not be detrimental to the surrounding area or the community's orderly development.

The developer proposes an outlot for stormwater retention, intended to service both the development parcel and the future South Armstrong Drive extension to the south. Details relating to maintenance of the retention pond will be brought back to Council through a development agreement, which should be required as a condition of the PUD approval.

Staff believe the site layout is adequate for first-phase access and not dissimilar to other developments of the like. The Planning Commission discussed some concerns with the site layout and the ability for fire trucks to turn around. The Commission approved the PUD conditional upon the Fire Department providing to Council an opinion on the layout. The Fire Chief's comment is attached. If the site were to expand in the future as indicated on the PUD site plan, a second access would likely be needed to adequately handle increased traffic at the site.

More details for this PUD are located in the attached resolution. Staff recommend approval.

Budget Impact: Road and utility maintenance for any extension of South Armstrong Drive. Likely maintenance for the stormwater retention pond.

- Attachments: (1) Resolution 2023-25
(3) PUD site plan
(4) Application for PUD
(5) Planning Commission Resolution 2023-3
(6) Fire Department comment

Council Action: Date:

CITY OF FAIRMONT, MN
CITY COUNCIL RESOLUTION 2023-25

APPROVAL OF THE PLANNED UNIT DEVELOPMENT OF THE
FAIRMONT INDUSTRIAL PARK TWELFTH ADDITION

WHEREAS, Midwest Shop Condos LLC (“Applicant”) has submitted an application for a Planned Unit Development for approval for the Fairmont Industrial Park Twelfth Addition, located at Lot 1 of Block 1 of the Fairmont Industrial Park Twelfth Addition in the City of Fairmont, owned by Fairmont Growth Opportunity Corporation (“Property Owner”), as depicted in Exhibit A (the “PUD”), which is attached hereto and incorporated herein by reference, and as legally described as follows:

Lot 1, Block 1, of Fairmont Industrial Park 12th Addition (the “Property”); and

WHEREAS, the Applicant is the intended purchaser of the above-described Property and the PUD is contingent upon the Applicant closing on the purchase of the Property from the current owners and recording the deed of conveyance for the same within six months of the date of this Resolution, or the PUD shall be null and void without further action by the City Council following the expiration of such six month period; and

WHEREAS, pursuant to Fairmont City Code, Section 26-280, the review and evaluation of a proposed planned unit development shall include but not be limited to the following criteria:

- (1) Adequate property control is established and provided to protect the individual owner's rights and property values and to define legal responsibilities for maintenance and upkeep.
- (2) The interior circulation plan plus access from and onto public right-of-ways does not create congestion or dangers and is adequate for the safety of the project residents and general public.
- (3) A sufficient amount of usable open space is provided.
- (4) The arrangement of buildings, structures and accessory uses does not unreasonably disturb the privacy or property values of the surrounding uses.
- (5) The architectural design of the project is compatible with the surrounding area.
- (6) The drainage and utility system plans are submitted to the city engineer and are subject to his approval.

(7) The development schedule insures a logical development of the site which will protect the public interest and concerned landowners.

(8) Principal and accessory uses, and requirements are in compliance with the district provisions in which the development is intended.

(9) The performance standards of this chapter are complied with.

(10) Planned unit developments in shoreland management areas meet regulations and requirements listed in article VII. Such developments shall be subject to review by the state department of natural resources.

(11) The provisions of article II, division 4 are considered and satisfactorily met.

WHEREAS, City Staff and the Fairmont Planning Commission have reviewed the submission of the PUD on the Property and have determined that it meets the above criteria contained in City Code; and

WHEREAS, the Planning Commission considered the Applicant's request for the PUD at a duly noticed Public Hearing, which took place on June 6, 2023, and recommended approval to the City Council with conditions; and

WHEREAS, a Development Agreement is required and shall be prepared between the City of Fairmont and Midwest Shop Condos LLC, which outlines the responsibilities of Midwest Shop Condos LLC to install the required street and infrastructure improvements necessary to support development on the Property within the PUD; and

WHEREAS, the City Council of the City of Fairmont has reviewed the PUD of the Fairmont Industrial Park Twelfth Addition for compliance with Fairmont City Code and statutes of the State of Minnesota.

NOW, THEREFORE, BE IT RESOLVED BY THE CITY COUNCIL THAT, the City Council hereby adopts the Findings of Fact contained in Exhibit B addressing the required criteria contained in Fairmont City Code, Section 26-2808.5.12 (2), and the PUD of the Fairmont Industrial Park Twelfth Addition is hereby approved, subject to the following conditions:

1. The PUD shall comply with the provisions of all state statutes and standard procedures for platting in Martin County.
2. Prior to the City's execution of the PUD and before any building permits are issued for development on the Property, the Applicant must enter into and record an agreement with the City for the installation of all required improvements, which shall be referred to as the "Development Agreement," and the Applicant shall provide the required security contained therein.

3. The requirements and conditions of the Development Agreement shall be incorporated as conditions of the City's execution of the PUD.
4. The PUD shall be recorded by the Applicant within 90 days of the City Council's approval of this Resolution or the City's approval hereof shall be deemed null and void without further action by the City Council following the expiration of such period, unless a written request for extension has been made by the Applicant stating the reasons why an extension is necessary and approved by the City Council.
5. The Applicant shall pay all fees, including by not limited to recording fees.

PASSED by the City Council of the City of Fairmont on this 26th day of June, 2023.

ATTEST

City Clerk

Mayor

EXHIBIT A

Depiction of PUD

FAIRMONT COMMERCIAL CONDOMINIUMS
KEY CITY GROUP, LLC

PUD PLAN
MAY 2023

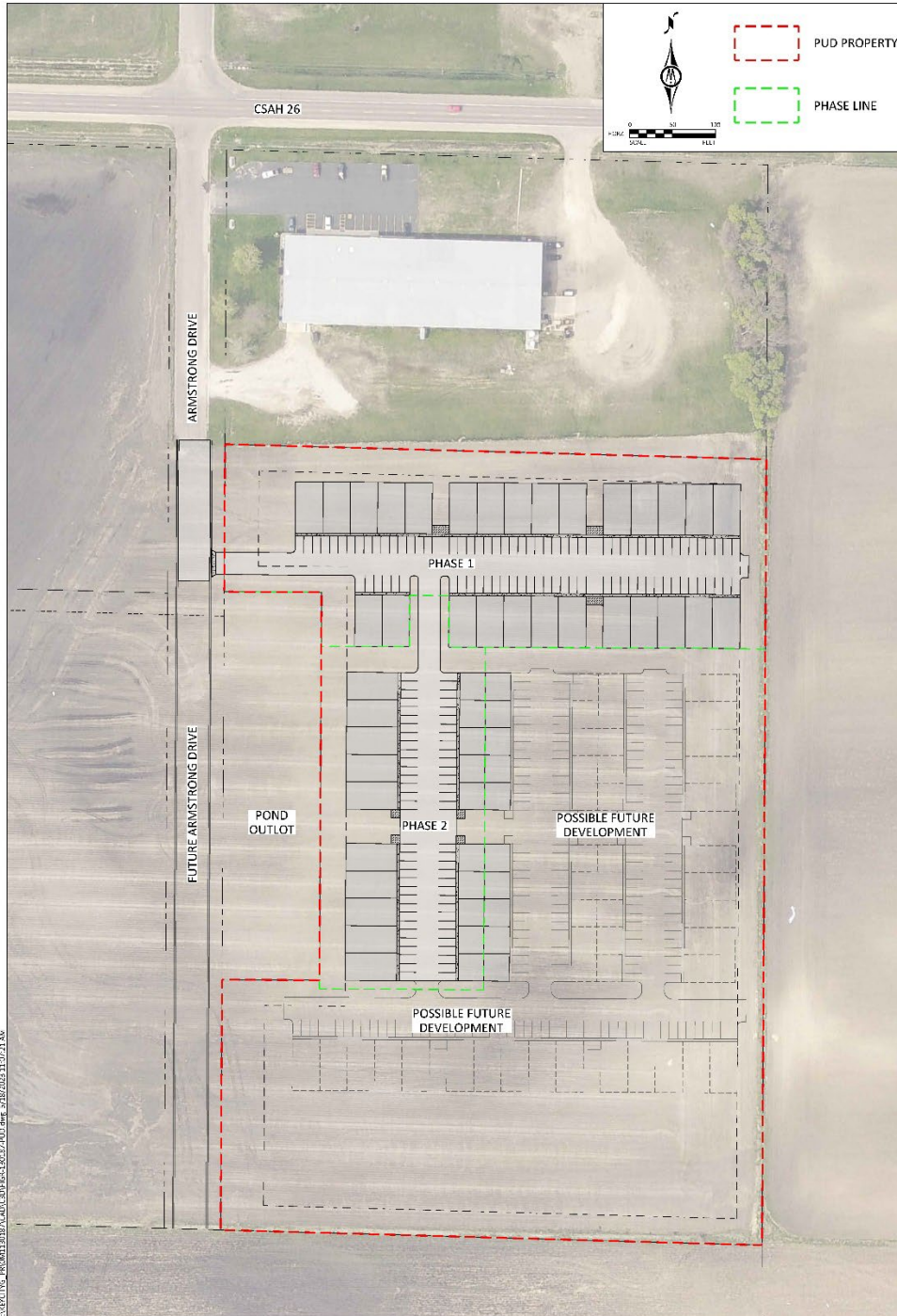

\\svefctvc-prod\m118707460\crofpa\130\17\PAUD.dwg 2/28/2023 11:27:21 AM

EXHIBIT B

Findings of Fact

Fairmont City Code, Section 26-280, requires the review and evaluation of the PUD pursuant to, but not be limited to, the following criteria:

(1) Adequate property control is established and provided to protect the individual owner's rights and property values and to define legal responsibilities for maintenance and upkeep.

The applicant proposes a CIC declaration which will establish property control.

(2) The interior circulation plan plus access from and onto public rights-of-way does not create congestion or dangers and is adequate for the safety of the project residents and general public.

Planning and Engineering staff have reviewed the site layout and find it to be adequate for the safety of project residents and the public.

(3) A sufficient amount of usable open space is provided.

The proposed amount of open space is typical for industrial developments of this kind.

(4) The arrangement of buildings, structures and accessory uses does not unreasonably disturb the privacy or property values of the surrounding uses.

The arrangement of buildings, structures, and accessory uses will not unreasonably disturb the privacy or property values of the surrounding uses, which are similar industrial uses.

(5) The architectural design of the project is compatible with the surrounding area.

The architecture proposed is compatible with the surrounding industrial area.

(6) The drainage and utility system plans are submitted to the city engineer and are subject to his approval.

The applicant proposes to comply with this requirement.

(7) The development schedule insures a logical development of the site which will protect the public interest and concerned landowners.

The proposal divides the project into logical phases.

(8) Principal and accessory uses, and requirements are in compliance with the district provisions in which the development is intended.

The uses proposed by the PUD, as well as associated requirements, are all compliant with the I-1 Light Industrial district.

(9) The performance standards of this chapter are complied with.

The applicant proposes no features which would violate zoning performance standards.

(10) Planned unit developments in shoreland management areas meet regulations and requirements listed in article VII. Such developments shall be subject to review by the state department of natural resources.

The development is not located within the Shoreland Management District.

(11) The provisions of article II, division 4 are considered and satisfactorily met.

- a. Must be in conformance with the comprehensive plan.

Fairmont Forward: 2040 Comprehensive Plan visions a pattern of land use that provides “a purposeful balance of residential neighborhoods, commercial districts, and industrial areas”. The proposed use meets this vision by providing a space for a number of light industrial uses to operate away from residences and commercial centers.

The Plan goes on to prioritize “efficient, effective, and sustainable” use of transportation and other public infrastructure. By locating the development off of the existing light industrial corridor of western Lake Avenue and by proposing the logical extension of Armstrong Avenue, the proposal meets the intent of this priority.

- b. Must not be detrimental or injurious to the general vicinity and uses already permitted in the area.

The proposed use and intensity of the use are typical for the area. The use is surrounded by other light industrial uses and undeveloped farmland outside city limits.

- c. Must not impede the normal and orderly development of surrounding vacant property.

By proposing that Armstrong Drive will extend to the south unimpeded and without any unordered lot lines or stretches of inefficient right-of-way, the development meets this standard.

- d. Must be served by adequate utilities, public roads, and municipal facilities. Such requirements shall not be detrimental to the economic welfare of the city.

The proposal would be served by the proper utilities extending with Armstrong Drive, and site drainage will be adequately managed per relevant engineering standards.

- e. Must not cause offensive odors, fumes, dust, noise, or vibration that would be injurious or a nuisance to adjacent uses or the surrounding area.

The applicant does not propose any uses which would be injurious to the surrounding area. The uses allowable at this site are the same that are allowable in the underlying district.

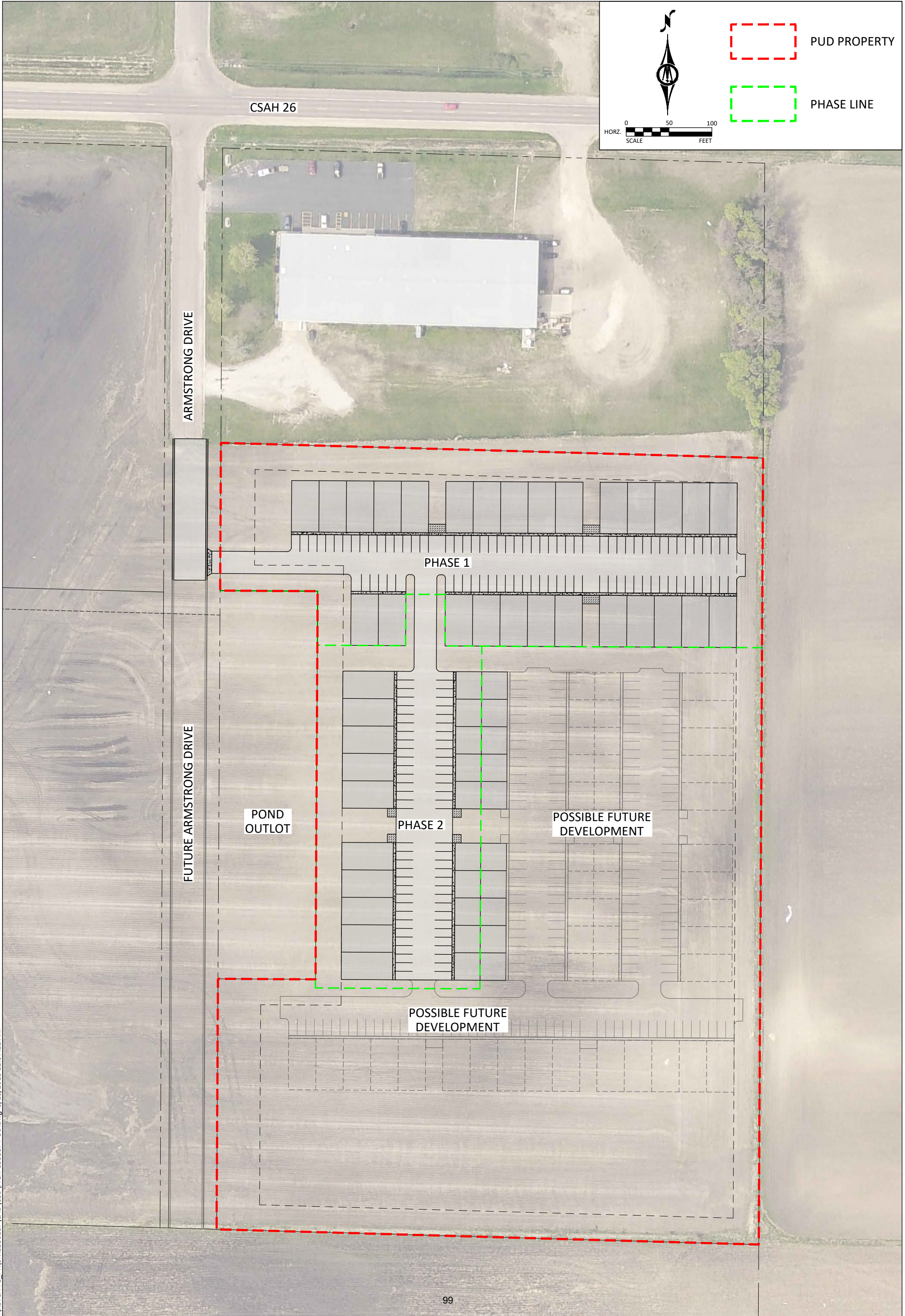

H:\KEY\CITYG_PR\01130187\CAD\C3D\FIGR-130187-PUD.dwg 5/18/2023 11:07:21 AM

**CITY OF FAIRMONT
Planning & Zoning
Application Form**

NOTE TO APPLICANT: This is a comprehensive application form. Only those items related to your specific type of development are to be completed. All items applicable must be included prior to acceptance of the application.

Name of Applicant: Daniel Sprague (Midwest Shop Condos LLC) Address: P.O. Box 426 Phone#: [REDACTED]
Mankato MN 56002

Street Address of Proposal: TBD

Legal Description of Property: Lot 1 Block 1 of Fairmont Industrial Park
Rth Addition

Existing Use of Property: Farm Land

Proposed Use of Property: Shop Condos

Type of Application	Fee	Submission Requirements (Attached)
<input type="checkbox"/> Appeal/Code Amendment	\$150.00	7
<input type="checkbox"/> Administrative Appeal	50.00	8
<input type="checkbox"/> Conditional Use Permit	150.00	4, 6(d-g)
<input type="checkbox"/> Home Occupation Permit	30.00	9
<input type="checkbox"/> Minor Plat	90.00	2(a), 5 (a-b)
<input checked="" type="checkbox"/> Planned Unit Development	150.00	1, 4, 6(d-g)
<input type="checkbox"/> Preliminary Plat	150.00	5 (b), 6
<input type="checkbox"/> Rezoning	150.00	1
<input type="checkbox"/> Variance	90.00	2,3

I HEREBY CERTIFY THAT THE INFORMATION AND EXHIBITS HERewith SUBMITTED ARE TRUE AND CORRECT TO THE BEST OF MY KNOWLEDGE.

Daniel Sprague
 Owner's Name(Printed)

 Owner's Signature

Daniel Sprague
 Applicant's Name (Printed)

 Applicant's Signature

City Staff Use Only
DATE FILED: _____
DATE FEE PAID: _____
MEETING DATE: _____
NOTICES SENT (DATE): _____
NOTIFICATION OF EXTENSION (LETTER SENT): _____

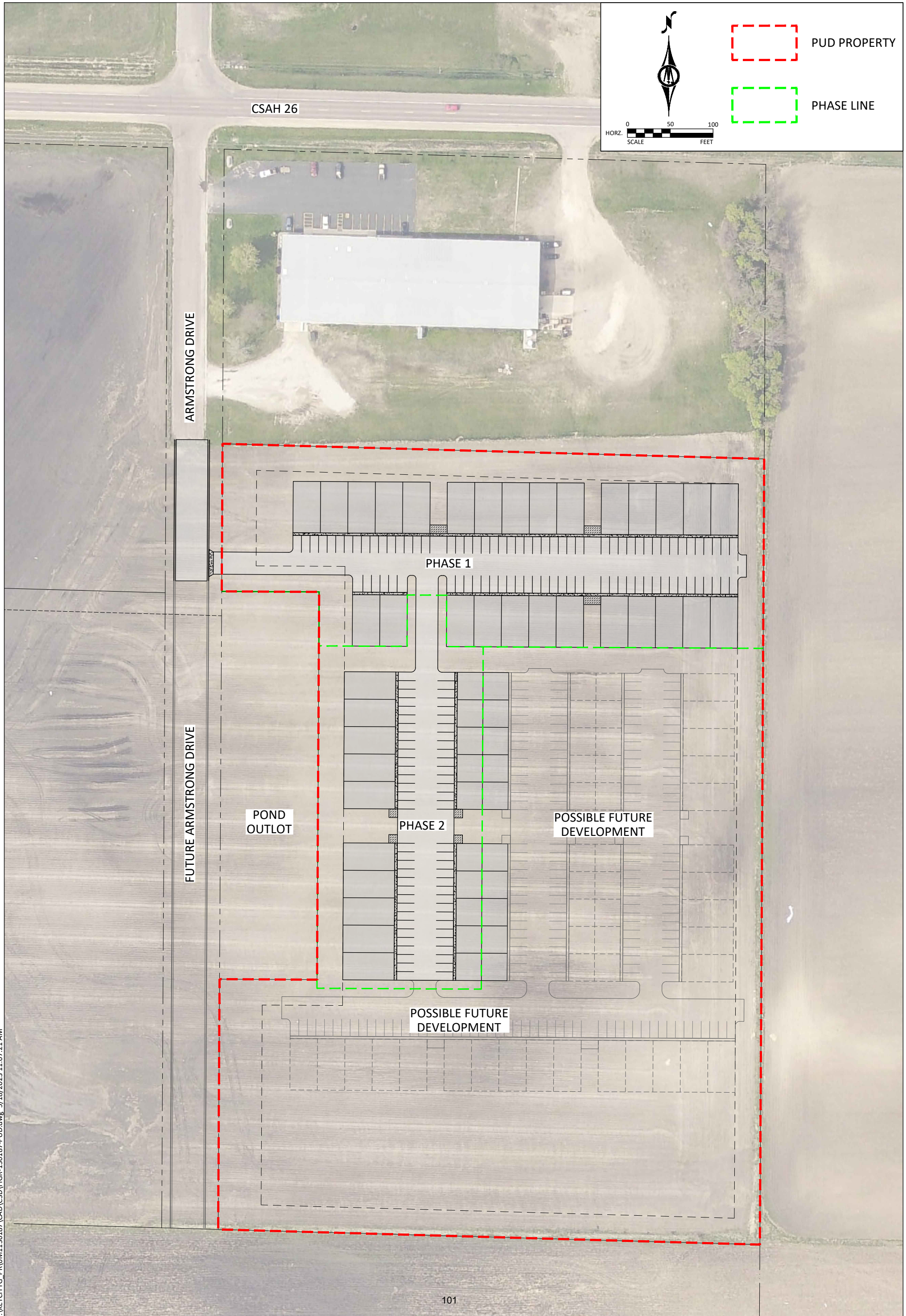

H:\KEY\CITYG_PR\01130187\CAD\C3D\FIGR-130187-PUD.dwg 5/18/2023 11:07:21 AM

KEY CITY GROUP, LLC

CONSTRUCTION PLANS FOR

FAIRMONT CONTRACTOR CONDOMINIUMS

FAIRMONT, MN

ROADWAY EXTENSION, PAVEMENT CONSTRUCTION, SITE AND POND GRADING
WATERMAIN, SANITARY SEWER AND STORM SEWER INSTALLATION

MAY 2023

MAP OF THE
CITY OF FAIRMONT
MARTIN COUNTY, MN



0 1000 2000
SCALE FEET

NOTE: EXISTING UTILITY INFORMATION SHOWN ON THIS PLAN HAS BEEN PROVIDED BY THE UTILITY OWNER. THE CONTRACTOR SHALL FIELD VERIFY EXACT LOCATIONS PRIOR TO COMMENCING CONSTRUCTION AS REQUIRED BY STATE LAW. NOTIFY GOPHER STATE ONE CALL, 1-800-252-1166 OR 651-454-0002.

THE SUBSURFACE UTILITY INFORMATION IN THIS PLAN IS UTILITY QUALITY LEVEL D UNLESS OTHERWISE NOTED. THIS UTILITY LEVEL WAS DETERMINED ACCORDING TO THE GUIDELINES OF CI/ASCE 38-02, ENTITLED "STANDARD GUIDELINES FOR THE COLLECTION AND DEPICTION OF EXISTING SUBSURFACE UTILITY DATA."

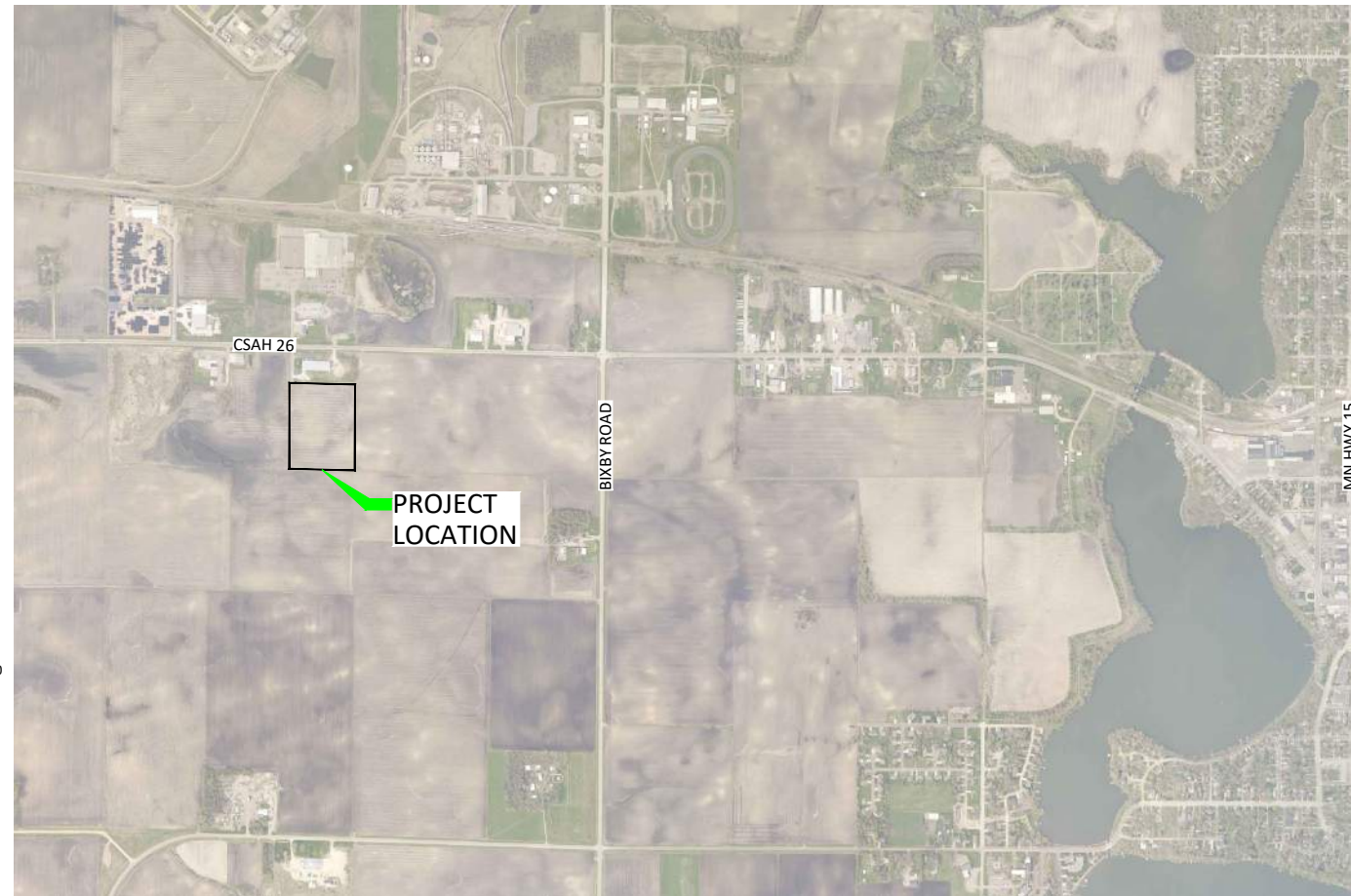

SHEET NUMBER	SHEET TITLE
GENERAL	
G0.01 - G0.02	TITLE SHEET & LEGEND
G1.01 - G1.02	PROJECT OVERVIEW
CIVIL - DETAILS & SWPPP	
C0.01	EXISTING CONDITIONS & REMOVAL PLAN
C1.01	SURFACE CONSTRUCTION DETAILS
C1.02	WATERMAIN & SANITARY SEWER DETAILS
C1.03	STORM SEWER DETAILS
STORMWATER POLLUTION PREVENTION PLAN	
C2.01 - C2.05	GENERAL INFORMATION & DETAILS
C2.06 - C2.07	EROSION & SEDIMENT CONTROL PLAN
CIVIL - PUBLIC IMPROVEMENTS	
C3.01 - C3.04	ARMSTRONG DRIVE EXTENSION
C3.05 - C3.06	STORMWATER MANAGEMENT PLAN
CIVIL - PRIVATE IMPROVEMENTS	
GRADING PLAN	
C4.01 - C4.04	GRADING PLAN
SANITARY AND WATER SERVICE PLAN, DRAINAGE PLAN	
C5.01 - C5.03	SANITARY AND WATER PLAN & PROFILES
C5.04	DRAINAGE PLAN
SITE PLAN	
C6.01	SITE PLAN

THIS PLAN SET CONTAINS 30 SHEETS.

NOTE:
THE TOPOGRAPHIC SURVEY FOR THIS PROJECT WAS COMPLETED BY A PARTY OTHER THAN BOLTON & MENK. THIS DESIGN AND PLAN IS BASED ON THE ACCURACY OF THE SURVEY PERFORMED "BY OTHERS"

I HEREBY CERTIFY THAT THIS PLAN, SPECIFICATION, OR REPORT WAS PREPARED BY ME OR UNDER MY DIRECT SUPERVISION AND THAT I AM A DULY LICENSED PROFESSIONAL ENGINEER UNDER THE LAWS OF THE STATE OF MINNESOTA.
NOT FOR CONSTRUCTION
ALEC W. PIETZ, P.E.
LIC. NO. 59617 DATE XX/XX/XXXX



1960 PREMIER DRIVE
MANKATO, MINNESOTA 56001
Phone: (507) 625-4171
Email: Mankato@bolton-menk.com
www.bolton-menk.com

DESIGNED	NO.	ISSUED FOR	DATE
AWP			
DRAWN			
AWP			
CHECKED			
MS			
CLIENT PROJ. NO.			
0M1-130187			

KEY CITY GROUP, LLC
FAIRMONT CONTRACTOR CONDOMINIUMS
TITLE SHEET

SHEET
G0.01

EXISTING TOPOGRAPHIC SYMBOLS

	ACCESS GRATE		REGULATION STATION GAS
	AIR CONDITION UNIT		SATELLITE DISH
	ANTENNA		SIGN NON TRAFFIC
	AUTO SPRINKLER CONNECTION		SIGN TRAFFIC
	BARRICADE PERMANENT		SIGNAL CONTROL CABINET
	BASKETBALL POST		SOIL BORING
	BENCH		SIREN
	BIRD FEEDER		TELEPHONE BOOTH
	BOLLARD		TILE INLET
	BUSH		TILE OUTLET
	CATCH BASIN RECTANGULAR CASTING		TILE RISER
	CATCH BASIN CIRCULAR CASTING		TRANSFORMER-ELECTRIC
	CURB STOP		TREE-CONIFEROUS
	CLEAN OUT		TREE-DEAD
	CULVERT END		TREE-DECIDUOUS
	DRINKING FOUNTAIN		TREE STUMP
	DOWN SPOUT		TRAFFIC ARM BARRIER
	FILL PIPE		TRAFFIC SIGNAL
	FIRE HYDRANT		TRASH CAN
	FLAG POLE		UTILITY MARKER
	FLARED END / APRON		VALVE
	FUEL PUMP		VALVE POST INDICATOR
	GRILL		VALVE VAULT
	GUY WIRE ANCHOR		VAULT
	HANDHOLE		VENT PIPE
	HANDICAP SPACE		WATER SPIGOT
	IRRIGATION SPRINKLER HEAD		WELL
	IRRIGATION VALVE BOX		WETLAND DELINEATED MARKER
	LIFT STATION CONTROL PANEL		WETLAND
	LIFT STATION		WET WELL
	LIGHT ON POLE		YARD HYDRANT
	LIGHT-GROUND		
	MAILBOX		

PROPOSED TOPOGRAPHIC SYMBOLS

	CLEANOUT
	MANHOLE
	LIFT STATION
	STORM SEWER CIRCULAR CASTING
	STORM SEWER RECTANGULAR CASTING
	STORM SEWER FLARED END / APRON
	STORM SEWER OUTLET STRUCTURE
	STORM SEWER OVERFLOW STRUCTURE
	CURB BOX
	FIRE HYDRANT
	WATER VALVE
	WATER REDUCER
	WATER BEND
	WATER TEE
	WATER CROSS
	WATER SLEEVE
	WATER CAP / PLUG
	RIP RAP
	DRAINAGE FLOW
	TRAFFIC SIGNS

SURVEY SYMBOLS

	BENCHMARK LOCATION
	CONTROL POINT
	MONUMENT FOUND
	CAST IRON MONUMENT
	STONE MONUMENT

EXISTING TOPOGRAPHIC LINES

	RETAINING WALL
	FENCE
	FENCE-DECORATIVE
	GUARD RAIL
	TREE LINE
	BUSH LINE

SURVEY LINES

	CONTROLLED ACCESS BOUNDARY
	CENTERLINE
	EXISTING EASEMENT LINE
	PROPOSED EASEMENT LINE
	EXISTING LOT LINE
	PROPOSED LOT LINE
	EXISTING RIGHT-OF-WAY
	PROPOSED RIGHT-OF-WAY
	SETBACK LINE
	SECTION LINE
	QUARTER LINE
	SIXTEENTH LINE
	TEMPORARY EASEMENT

EXISTING UTILITY LINES

	FORCEMAIN
	SANITARY SEWER
	SANITARY SERVICE
	STORM SEWER
	STORM SEWER DRAIN TILE
	WATERMAIN
	WATER SERVICE

PROPOSED UTILITY LINES

	FORCEMAIN
	SANITARY SEWER
	SANITARY SERVICE
	STORM SEWER
	STORM SEWER DRAIN TILE
	WATERMAIN
	WATER SERVICE
	PIPE CASING

GRADING INFORMATION

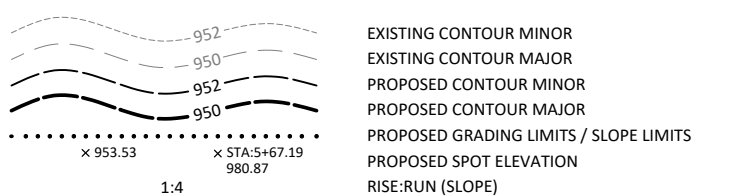

HATCH PATTERNS

	BITUMINOUS		GRAVEL
	CONCRETE		

EXISTING PRIVATE UTILITY LINES

NOTE:
EXISTING UTILITY INFORMATION SHOWN ON THIS PLAN HAS BEEN PROVIDED BY THE UTILITY OWNER. THE CONTRACTOR SHALL FIELD VERIFY EXACT LOCATIONS PRIOR TO COMMENCING CONSTRUCTION AS REQUIRED BY STATE LAW. NOTIFY GOPHER STATE ONE CALL, 1-800-252-1166 OR 651-454-0002.

THE SUBSURFACE UTILITY INFORMATION IN THIS PLAN IS UTILITY QUALITY LEVEL D UNLESS OTHERWISE NOTED. THIS UTILITY LEVEL WAS DETERMINED ACCORDING TO THE GUIDELINES OF CI/ASCE 38-02, ENTITLED "STANDARD GUIDELINES FOR THE COLLECTION AND DEPICTION OF EXISTING SUBSURFACE UTILITY DATA"

	UNDERGROUND FIBER OPTIC
	UNDERGROUND ELECTRIC
	UNDERGROUND GAS
	UNDERGROUND COMMUNICATION
	OVERHEAD ELECTRIC
	OVERHEAD COMMUNICATION
	OVERHEAD UTILITY

UTILITIES IDENTIFIED WITH A QUALITY LEVEL:

LINE TYPES FOLLOW THE FORMAT: UTILITY TYPE - QUALITY LEVEL
EXAMPLE: G-A UNDERGROUND GAS, QUALITY LEVEL A
UTILITY QUALITY LEVEL (A,B,C,D) DEFINITIONS CAN BE FOUND IN CI/ASCE 38-02.

UTILITY QUALITY LEVELS:

QUALITY LEVEL D: PROVIDES THE MOST BASIC LEVEL OF INFORMATION. IT INVOLVES COLLECTING DATA FROM EXISTING UTILITY RECORDS. RECORDS MAY INCLUDE AS-BUILT DRAWINGS, DISTRIBUTION AND SERVICES MAPS, EXISTING GEOGRAPHIC INFORMATION SYSTEM DATABASES, CONSTRUCTION PLANS, ETC.

QUALITY LEVEL C: INVOLVES SURVEYING VISIBLE SUBSURFACE UTILITY STRUCTURES SUCH AS MANHOLES, HAND-HOLES, UTILITY VALVES AND METERS, FIRE HYDRANTS, PEDESTALS AND UTILITY MARKERS, AND THEN CORRELATING THE INFORMATION WITH EXISTING UTILITY RECORDS TO CREATE COMPOSITE DRAWINGS. INCLUDES QUALITY LEVEL D ACTIVITIES.

QUALITY LEVEL B: INVOLVES DESIGNATING THE HORIZONTAL POSITION OF SUBSURFACE UTILITIES THROUGH SURFACE DETECTION METHODS AND COLLECTING THE INFORMATION THROUGH A SURVEY METHOD. INCLUDES QUALITY LEVEL C AND D TASKS.

QUALITY LEVEL A: PROVIDES THE HIGHEST LEVEL OF ACCURACY. IT INVOLVES LOCATING OR POTHOLING UTILITIES AS WELL AS ACTIVITIES IN QUALITY LEVELS B, C, AND D. THE LOCATED FACILITY INFORMATION IS SURVEYED AND MAPPED AND THE DATA PROVIDES PRECISE PLAN AND PROFILE INFORMATION.

ABBREVIATIONS

A	ALGEBRAIC DIFFERENCE	GRAV	GRAVEL	RSC	RIGID STEEL CONDUIT
ADJ	ADJUST	GU	GUTTER	RT	RIGHT
ALT	ALTERNATE	GV	GATE VALVE	SAN	SANITARY SEWER
B-B	BACK TO BACK	HDPE	HIGH DENSITY POLYETHYLENE	SCH	SCHEDULE
BIT	BITUMINOUS	HH	HANDHOLE	SERV	SERVICE
BLDG	BUILDING	HP	HIGH POINT	SHLD	SHOULDER
BMP	BEST MANAGEMENT PRACTICE	HWL	HIGH WATER LEVEL	STA	STATION
BR	BEGIN RADIUS	HYD	HYDRANT	STD	STANDARD
BV	BUTTERFLY VALVE	I	INVERT	STM	STORM SEWER
CB	CATCH BASIN	K	CURVE COEFFICIENT	TC	TOP OF CURB
C&G	CURB AND GUTTER	L	LENGTH	TE	TEMPORARY EASEMENT
CIP	CAST IRON PIPE	LO	LOWEST OPENING	TEMP	TEMPORARY
CIPP	CURED-IN-PLACE PIPE	LP	LOW POINT	TNH	TOP NUT HYDRANT
CL	CENTER LINE	LT	LEFT	TP	TOP OF PIPE
CL	CLASS	MAX	MAXIMUM	TYP	TYPICAL
CLVT	CULVERT	MH	MANHOLE	VCP	VITRIFIED CLAY PIPE
CMP	CORRUGATED METAL PIPE	MIN	MINIMUM	VERT	VERTICAL
C.O.	CHANGE ORDER	MR	MID RADIUS	VPC	VERTICAL POINT OF CURVE
COMM	COMMUNICATION	NIC	NOT IN CONTRACT	VPI	VERTICAL POINT OF INTERSECTION
CON	CONCRETE	NMC	NON-METALLIC CONDUIT	VPT	VERTICAL POINT OF TANGENT
CSP	CORRUGATED STEEL PIPE	NTS	NOT TO SCALE	WM	WATERMAIN
DIA	DIAMETER	NWL	NORMAL WATER LEVEL		
DIP	DUCTILE IRON PIPE	OHW	ORDINARY HIGH WATER LEVEL		
DWY	DRIVEWAY	PC	POINT OF CURVE	AC	ACRES
E	EXTERNAL CURVE DISTANCE	PCC	POINT OF COMPOUND CURVE	CF	CUBIC FEET
ELEC	ELECTRIC	PE	PERMANENT EASEMENT	CV	COMPACTED VOLUME
ELEV	ELEVATION	PED	PEDESTRIAN, PEDESTAL	CY	CUBIC YARD
EOF	EMERGENCY OVERFLOW	PERF	PERFORATED PIPE	EA	EACH
ER	END RADIUS	PERM	PERMANENT	EV	EXCAVATED VOLUME
ESMT	EASEMENT	PI	POINT OF INTERSECTION	LB	POUND
EX	EXISTING	PL	PROPERTY LINE	LF	LINEAR FEET
FES	FLARED END SECTION	PRC	POINT OF REVERSE CURVE	LS	LUMP SUM
F-F	FACE TO FACE	PT	POINT OF TANGENT	LV	LOOSE VOLUME
FF	FINISHED FLOOR	PVC	POLYVINYL CHLORIDE PIPE	SF	SQUARE FEET
F&I	FURNISH AND INSTALL	PVMT	PAVEMENT	SV	STOCKPILE VOLUME
FM	FORCEMAIN	R	RADIUS	SY	SQUARE YARD
FO	FIBER OPTIC	R/W	RIGHT-OF-WAY		
F.O.	FIELD ORDER	RCP	REINFORCED CONCRETE PIPE		
GRAN	GRANULAR	RET	RETAINING		

© Bolton & Menk, Inc. 2023. All Rights Reserved. P:\M\130187\CD\130187-002.dwg 5/12/2023 7:23:34 AM

I HEREBY CERTIFY THAT THIS PLAN, SPECIFICATION, OR REPORT WAS PREPARED BY ME OR UNDER MY DIRECT SUPERVISION AND THAT I AM A DULY LICENSED PROFESSIONAL ENGINEER UNDER THE LAWS OF THE STATE OF MINNESOTA.
NOT FOR CONSTRUCTION
ALEX W. PIETZ, P.E.
LIC. NO. 59617 DATE XX/XX/XXXX



1960 PREMIER DRIVE
MANKATO, MINNESOTA 56001
Phone: (507) 625-4171
Email: Mankato@bolton-menk.com
www.bolton-menk.com

DESIGNED	NO.	ISSUED FOR	DATE
AWP			
AWP			
MS			
CLIENT PROJ. NO.	0M1.130187		

KEY CITY GROUP, LLC
FAIRMONT CONTRACTOR CONDOMINIUMS

LEGEND

SHEET

G0.02

© Bolton & Menk, Inc. 2023. All Rights Reserved.
A:\MCT\115_P\115130187\GD1.dwg 5/15/2023 7:23:52 AM

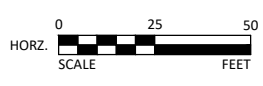
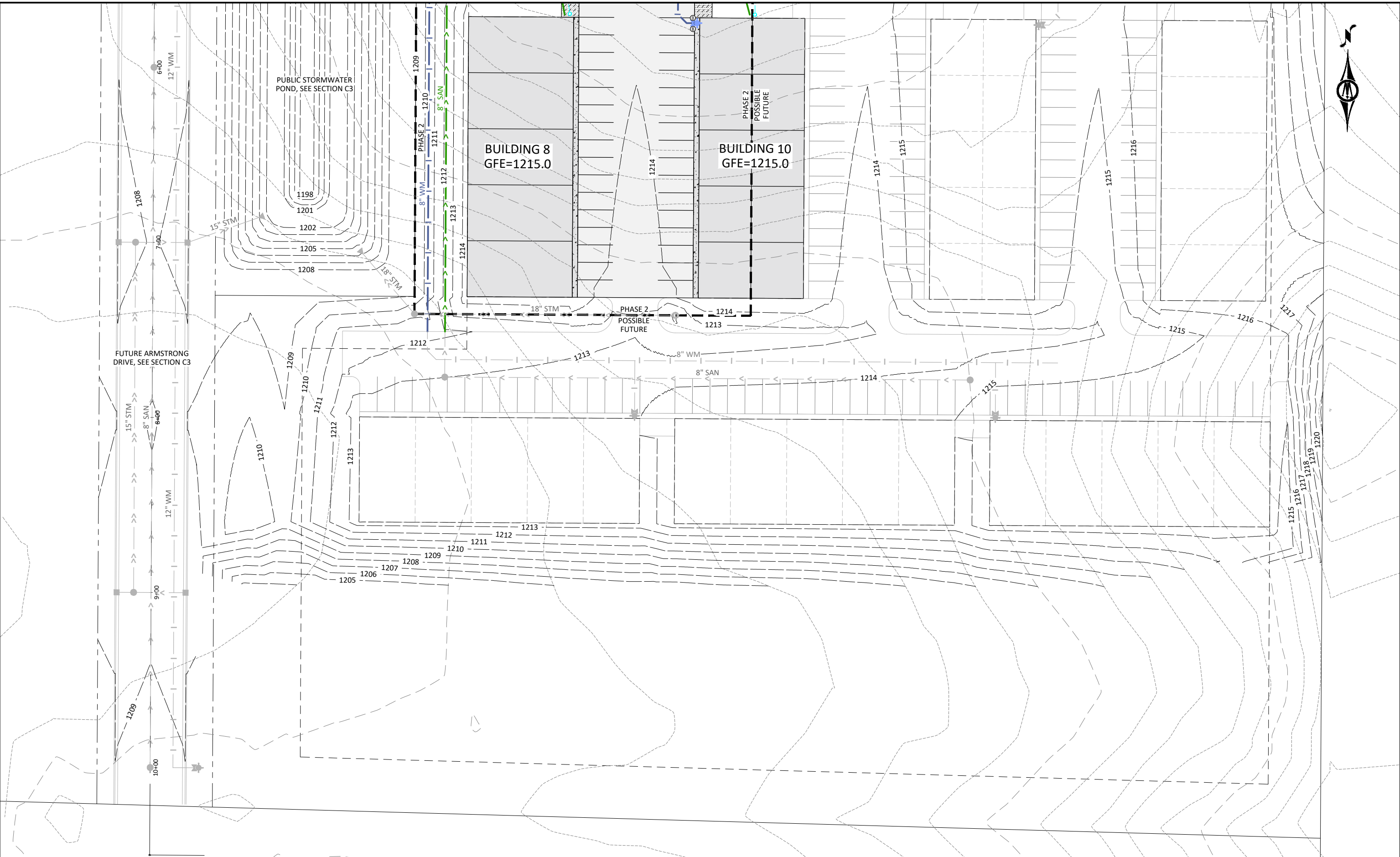

I HEREBY CERTIFY THAT THIS PLAN, SPECIFICATION, OR REPORT WAS PREPARED BY ME OR UNDER MY DIRECT SUPERVISION AND THAT I AM A DULY LICENSED PROFESSIONAL ENGINEER UNDER THE LAWS OF THE STATE OF MINNESOTA.
NOT FOR CONSTRUCTION
ALEX W. PIETZ, P.E.
LIC. NO. 59617 DATE XX/XX/XXXX



1960 PREMIER DRIVE
MANKATO, MINNESOTA 56001
Phone: (507) 625-4171
Email: Mankato@bolton-menk.com
www.bolton-menk.com

DESIGNED	NO.	ISSUED FOR	DATE
AWP			
DRAWN			
CHECKED			
MS			
CLIENT PROJ. NO.	0M1.130187		

KEY CITY GROUP, LLC
FAIRMONT CONTRACTOR CONDOMINIUMS
PROJECT OVERVIEW

SHEET
G1.01

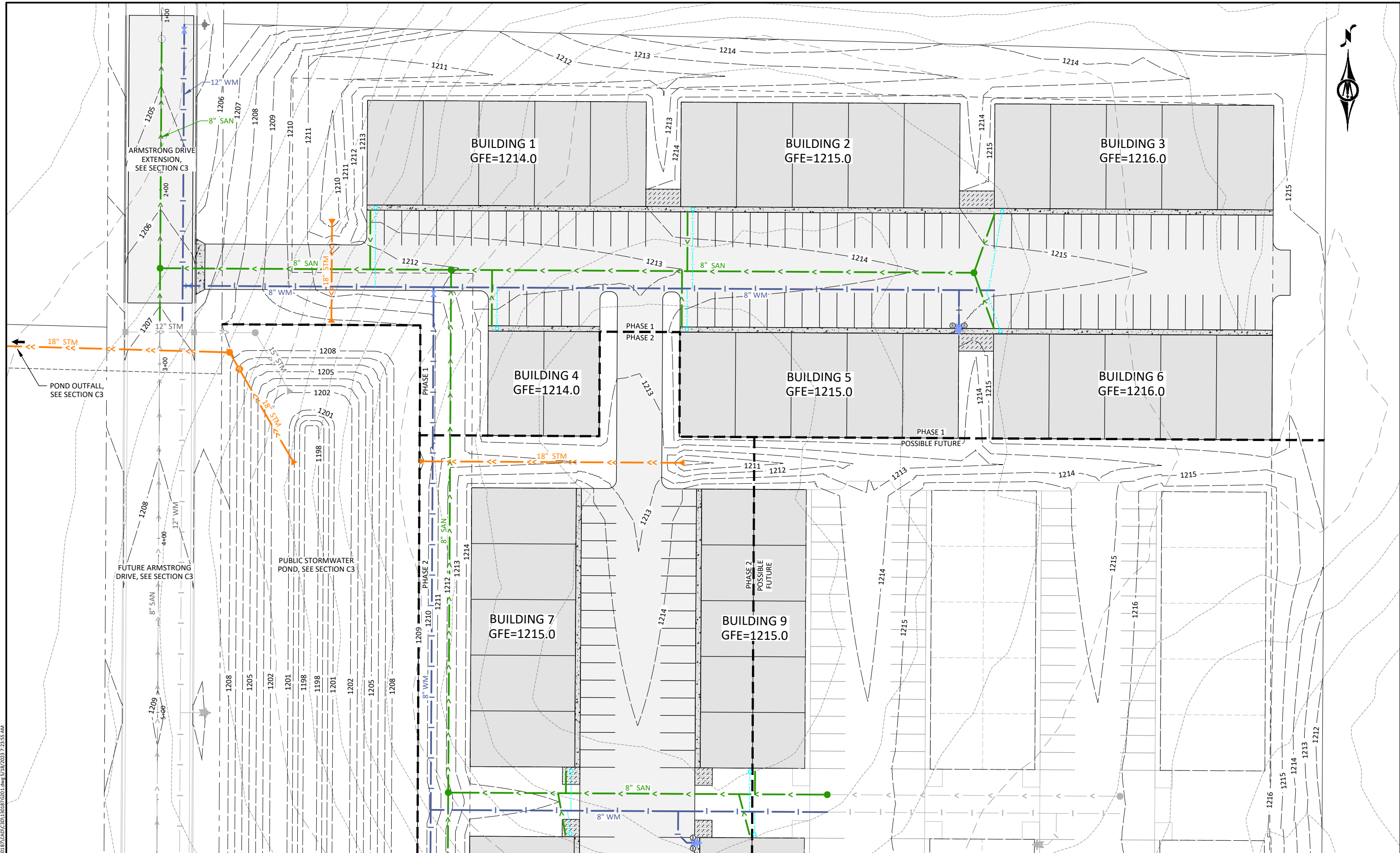

© Bolton & Menk, Inc. 2023. All Rights Reserved.
A:\MCT\115_P\115_P\115_P\115_P\115_P.dwg 5/12/2023 7:23:55 AM

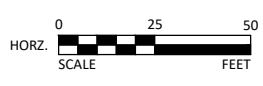

I HEREBY CERTIFY THAT THIS PLAN, SPECIFICATION, OR REPORT WAS PREPARED BY ME OR UNDER MY DIRECT SUPERVISION AND THAT I AM A DULY LICENSED PROFESSIONAL ENGINEER UNDER THE LAWS OF THE STATE OF MINNESOTA.
NOT FOR CONSTRUCTION
ALEC W. PIETZ, P.E.
LIC. NO. 59617 DATE XX/XX/XXXX



1960 PREMIER DRIVE
MANKATO, MINNESOTA 56001
Phone: (507) 625-4171
Email: Mankato@bolton-menk.com
www.bolton-menk.com

DESIGNED	NO.	ISSUED FOR	DATE
AWP			
DRAWN			
AWP			
CHECKED			
MS			
CLIENT PROJ. NO.	0M1.130187		

KEY CITY GROUP, LLC
FAIRMONT CONTRACTOR CONDOMINIUMS
PROJECT OVERVIEW

SHEET
G1.02

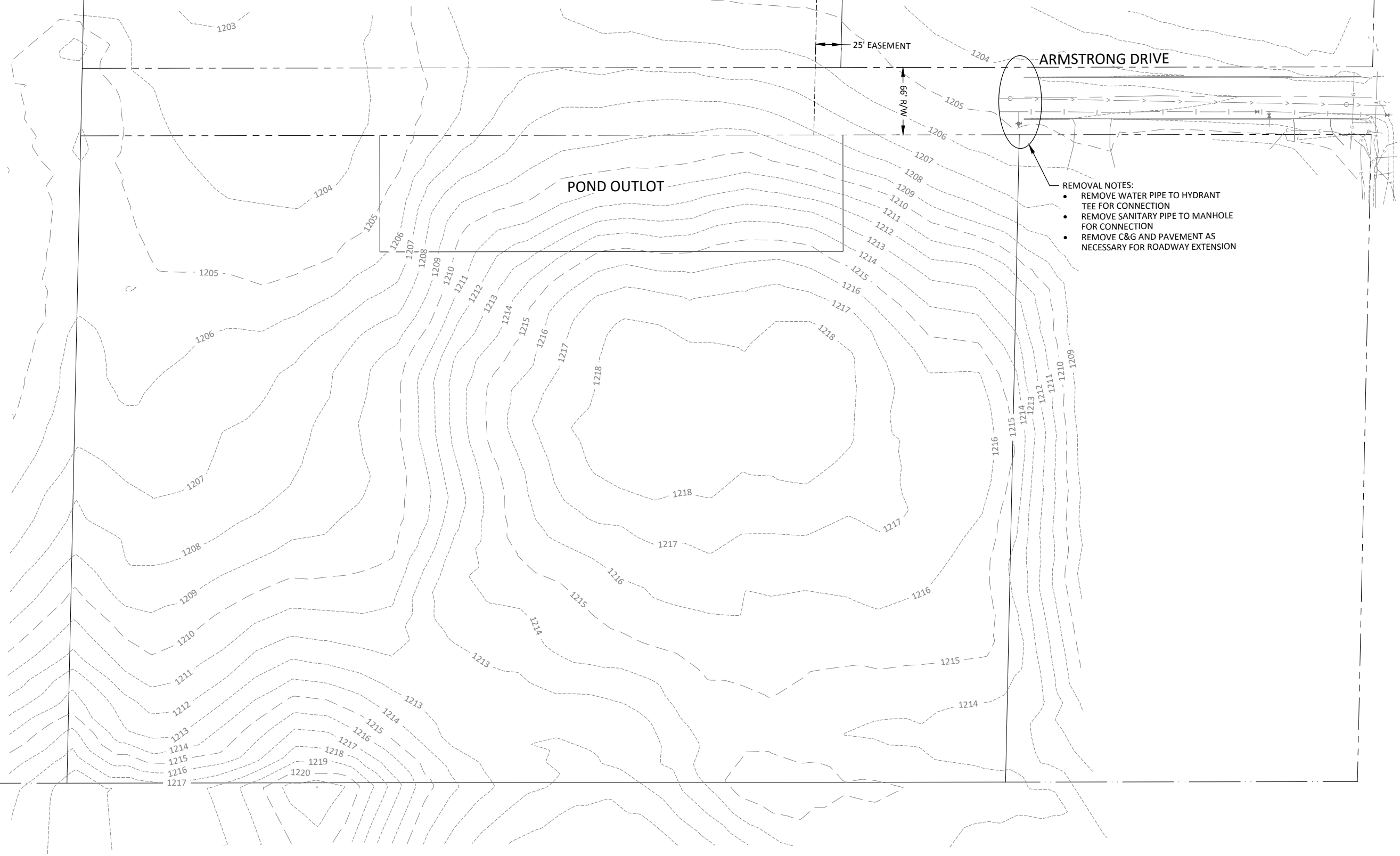

- REMOVAL NOTES:
- REMOVE WATER PIPE TO HYDRANT TEE FOR CONNECTION
 - REMOVE SANITARY PIPE TO MANHOLE FOR CONNECTION
 - REMOVE C&G AND PAVEMENT AS NECESSARY FOR ROADWAY EXTENSION

© Bolton & Menk, Inc. 2023. All Rights Reserved. A:\MCT\115_P\101\130187\130187.dwg 5/15/2023 7:24:06 AM

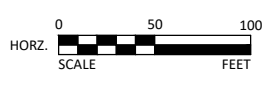

I HEREBY CERTIFY THAT THIS PLAN, SPECIFICATION, OR REPORT WAS PREPARED BY ME OR UNDER MY DIRECT SUPERVISION AND THAT I AM A DULY LICENSED PROFESSIONAL ENGINEER UNDER THE LAWS OF THE STATE OF MINNESOTA.

NOT FOR CONSTRUCTION

ALEC W. PIETZ, P.E.
LIC. NO. 59617 DATE XX/XX/XXXX



1960 PREMIER DRIVE
MANKATO, MINNESOTA 56001
Phone: (507) 625-4171
Email: Mankato@bolton-menk.com
www.bolton-menk.com

DESIGNED	NO.	ISSUED FOR	DATE
AWP			
AWP			
CHECKED			
MS			
CLIENT PROJ. NO.	0M1-130187		

KEY CITY GROUP, LLC
FAIRMONT CONTRACTOR CONDOMINIUMS
EXISTING CONDITIONS & REMOVAL PLAN

SHEET
C0.01

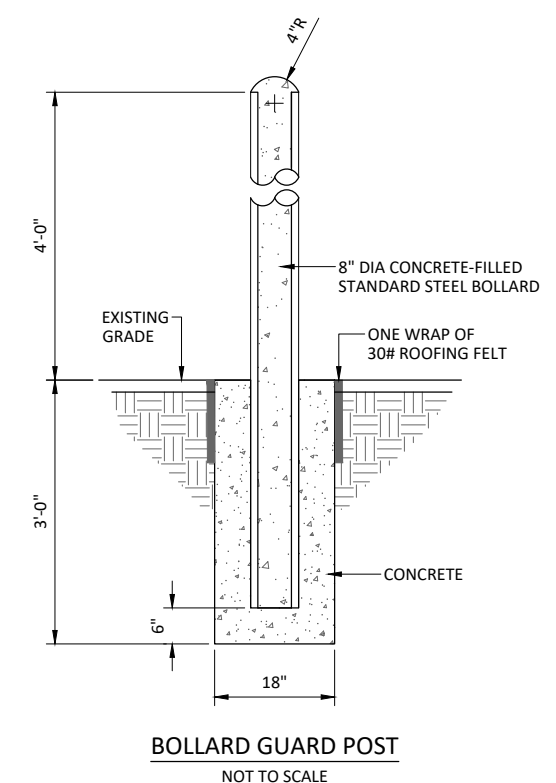
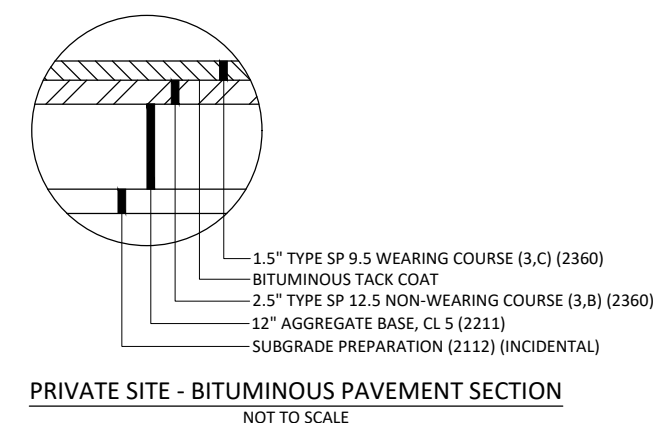
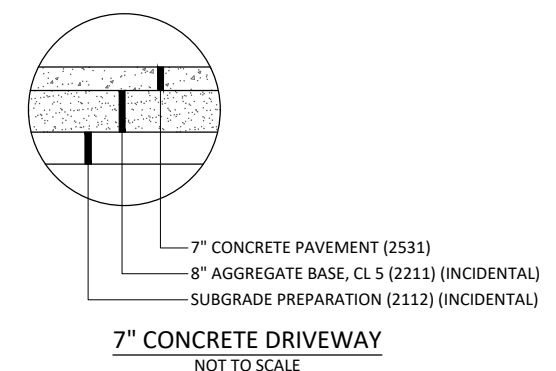
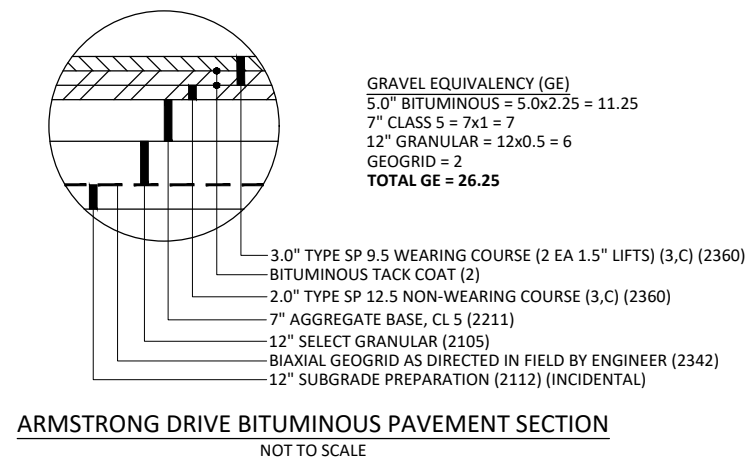
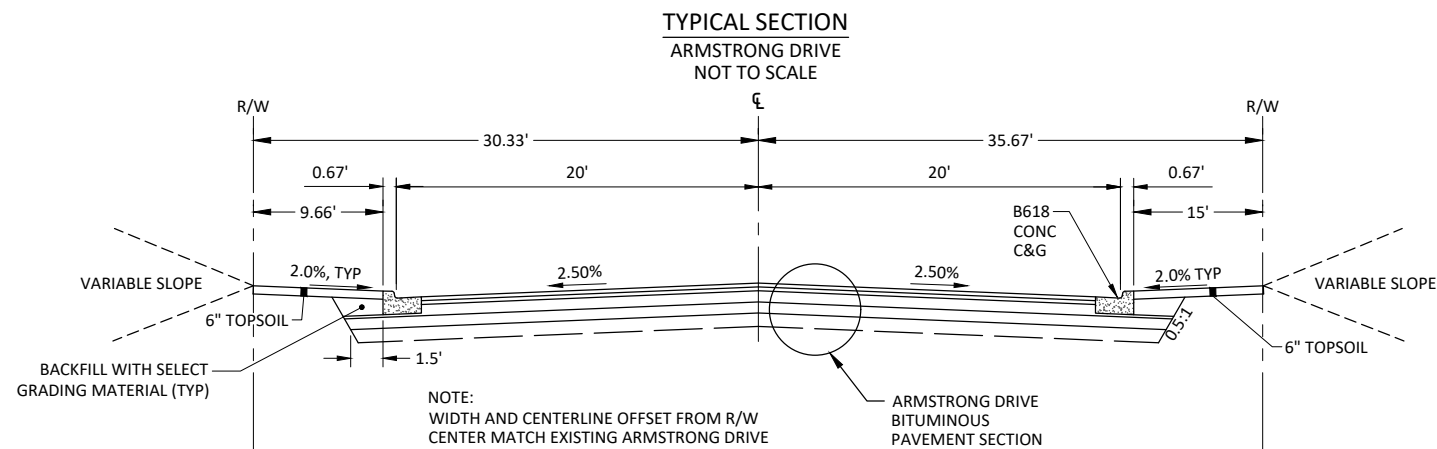

© Bolton & Menk, Inc. 2023. All Rights Reserved. A:\PROJECTS_P\191130187\CADD\C101\B0187_C101.dwg 5/15/2023 7:24:15 AM

I HEREBY CERTIFY THAT THIS PLAN, SPECIFICATION, OR REPORT WAS PREPARED BY ME OR UNDER MY DIRECT SUPERVISION AND THAT I AM A DULY LICENSED PROFESSIONAL ENGINEER UNDER THE LAWS OF THE STATE OF MINNESOTA.

NOT FOR CONSTRUCTION

ALEC W. PIETZ, P.E.
 LIC. NO. 59617 DATE XX/XX/XXXX



1960 PREMIER DRIVE
 MANKATO, MINNESOTA 56001
 Phone: (507) 625-4171
 Email: Mankato@bolton-menk.com
 www.bolton-menk.com

DESIGNED	NO.	ISSUED FOR	DATE
AWP			
DRAWN			
AWP			
CHECKED			
MS			
CLIENT PROJ. NO.	0M1-130187		

KEY CITY GROUP, LLC
 FAIRMONT CONTRACTOR CONDOMINIUMS
 SURFACE CONSTRUCTION DETAILS

SHEET
C1.01

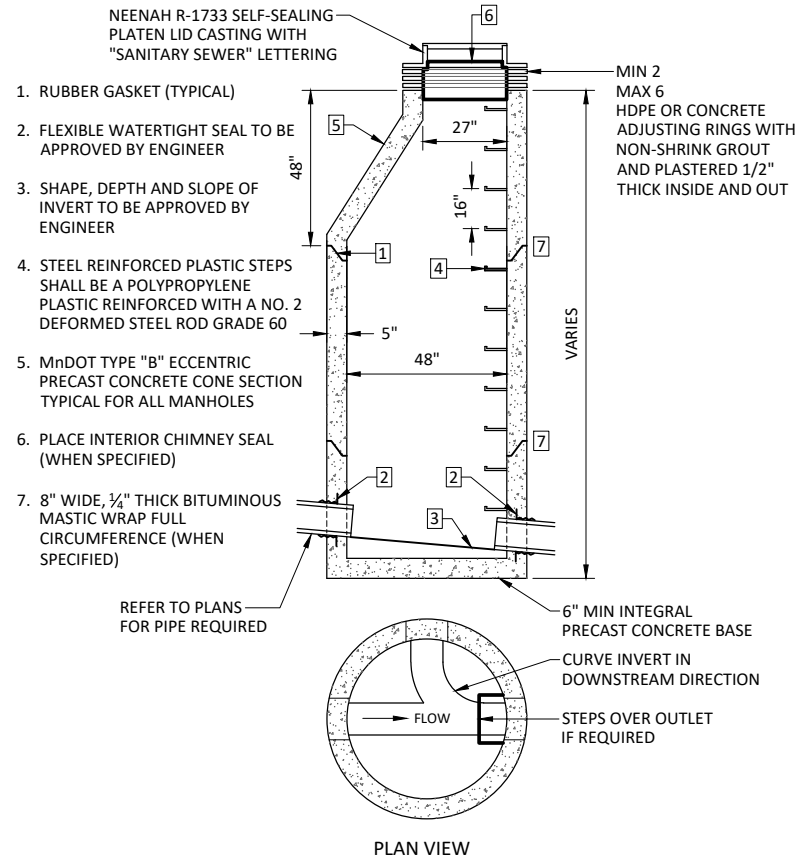

SANITARY MANHOLE (MNDOT DESIGN 4007C)
NOT TO SCALE

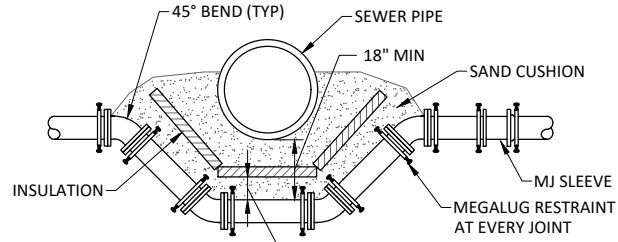

- NOTES:**
1. PROVIDE MEGALUG RESTRAINT AT JOINT ON BENDS AND AS SHOWN THIS DETAIL
 2. COAT ALL ANCHORAGE AS PER SPECS
 3. PROVIDE SAND CUSHION BETWEEN TOP OF WATERMAIN AND BOTTOM OF SEWER PIPE, MIN DIMENSIONS AS SHOWN THIS DETAIL (INCIDENTAL)
 4. INSULATION TO BE 2" THICK POLYSTYRENE (IF NECESSARY, INCIDENTAL)

WATERMAIN OFFSET
NOT TO SCALE

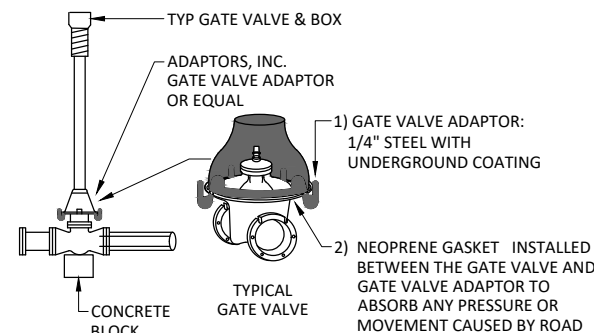

GATE VALVE ADAPTOR
NOT TO SCALE

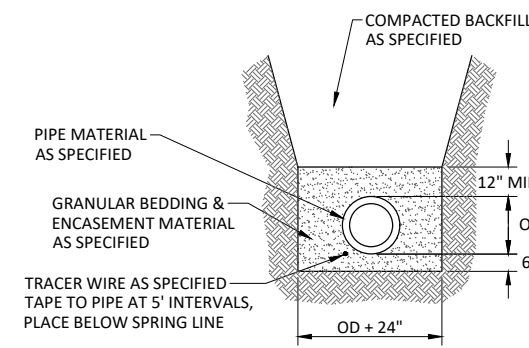

PVC WATERMAIN TRENCH
NOT TO SCALE

- NOTES:**
1. VALVE BOX SHALL BE CENTERED ON OPERATING NUTS, STRAIGHT, FREE FROM DEBRIS, AND ALL SECTIONS UNBROKEN
 2. VALVES IN EASEMENTS SHALL HAVE CHANNEL POST WITNESS MARKERS WITH REFLECTIVE "GV" SIGN
 3. DEEP VALVES SHALL HAVE NUT EXTENSIONS INSTALLED TO ELEVATION TO ACCOMMODATE STANDARD 10" KEY; BOTTOM NUT SHALL BE BOLTED TO VALVE NUT AND ONLY ONE SECTION
 4. COMPACTION WITH MECHANICAL TAMPER AROUND VALVE BOX SHALL BE PLACED AND COMPACTED WITH 2' LIFTS TO ACHIEVE 95% COMPACTION
 5. GATE VALVES LOCATED WITHIN THE CONCRETE SIDEWALK SHALL INCLUDE A METAL SEPARATOR BETWEEN THE VALVE BOX AND THE CONCRETE

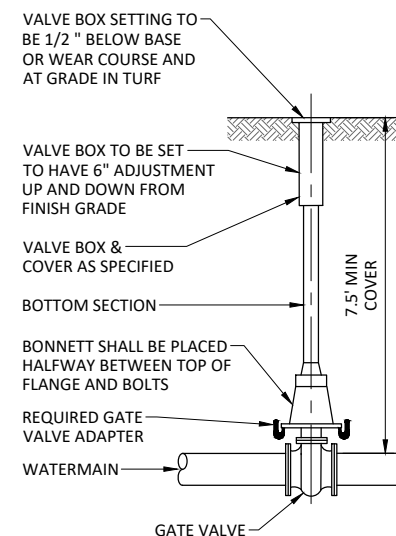

GATE VALVE BOX INSTALLATION
NOT TO SCALE

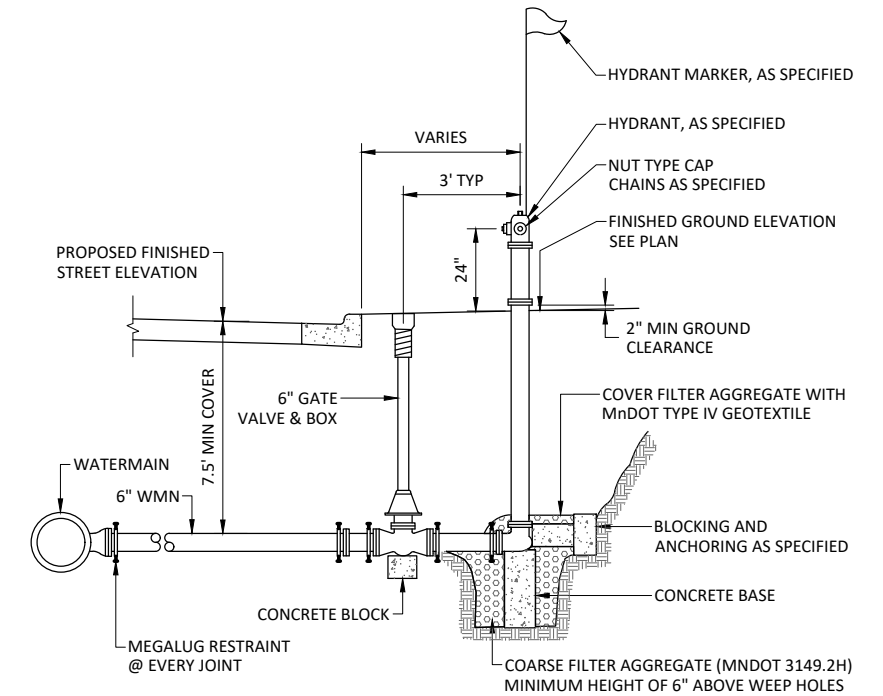

HYDRANT INSTALLATION, MEGALUGS
NOT TO SCALE

HYDRANTS LOCATED WHERE THE GROUNDWATER TABLE IS ABOVE THE DRAIN OUTLET SHALL HAVE THE OUTLET DRAIN PLUGGED AND SHALL BE EQUIPPED WITH A TAG STATING "PUMP AFTER USE"

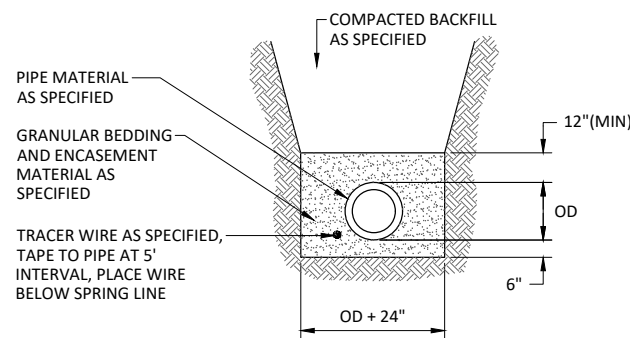

NON-RIGID SANITARY SEWER TRENCH
NOT TO SCALE

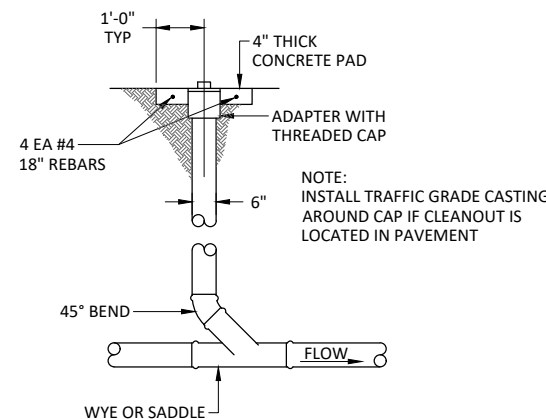

SANITARY SEWER CLEANOUT
NOT TO SCALE

TRACER WIRE NOTE:
REFER TO THE MINNESOTA RURAL WATER ASSOCIATION (MRWA) TRACER WIRE SPECIFICATION GUIDE & DETAILS TO PROPERLY INSTALL TRACER WIRE WITH WATERMAIN AND SANITARY SEWER. THE GUIDE CAN BE FOUND AT: mrwa.com/tools.html - Tracer Wire Specification Guide & Details

© Bolton & Menk, Inc. 2023. All Rights Reserved. A:\PROJECTS_P\BWA\30187\CD\30187.rvt.dwg 1/19/2023 7:24:15 AM

I HEREBY CERTIFY THAT THIS PLAN, SPECIFICATION, OR REPORT WAS PREPARED BY ME OR UNDER MY DIRECT SUPERVISION AND THAT I AM A DULY LICENSED PROFESSIONAL ENGINEER UNDER THE LAWS OF THE STATE OF MINNESOTA.
NOT FOR CONSTRUCTION
ALEX W. PIETZ, P.E.
LIC. NO. 59617 DATE XX/XX/XXXX



1960 PREMIER DRIVE
MANKATO, MINNESOTA 56001
Phone: (507) 625-4171
Email: Mankato@bolton-menk.com
www.bolton-menk.com

DESIGNED	NO.	ISSUED FOR	DATE
AWP			
AWP			
CHECKED			
MS			
CLIENT PROJ. NO.	0M1.130187		

KEY CITY GROUP, LLC
FAIRMONT CONTRACTOR CONDOMINIUMS
WATERMAIN & SANITARY SEWER DETAILS

SHEET
C1.02

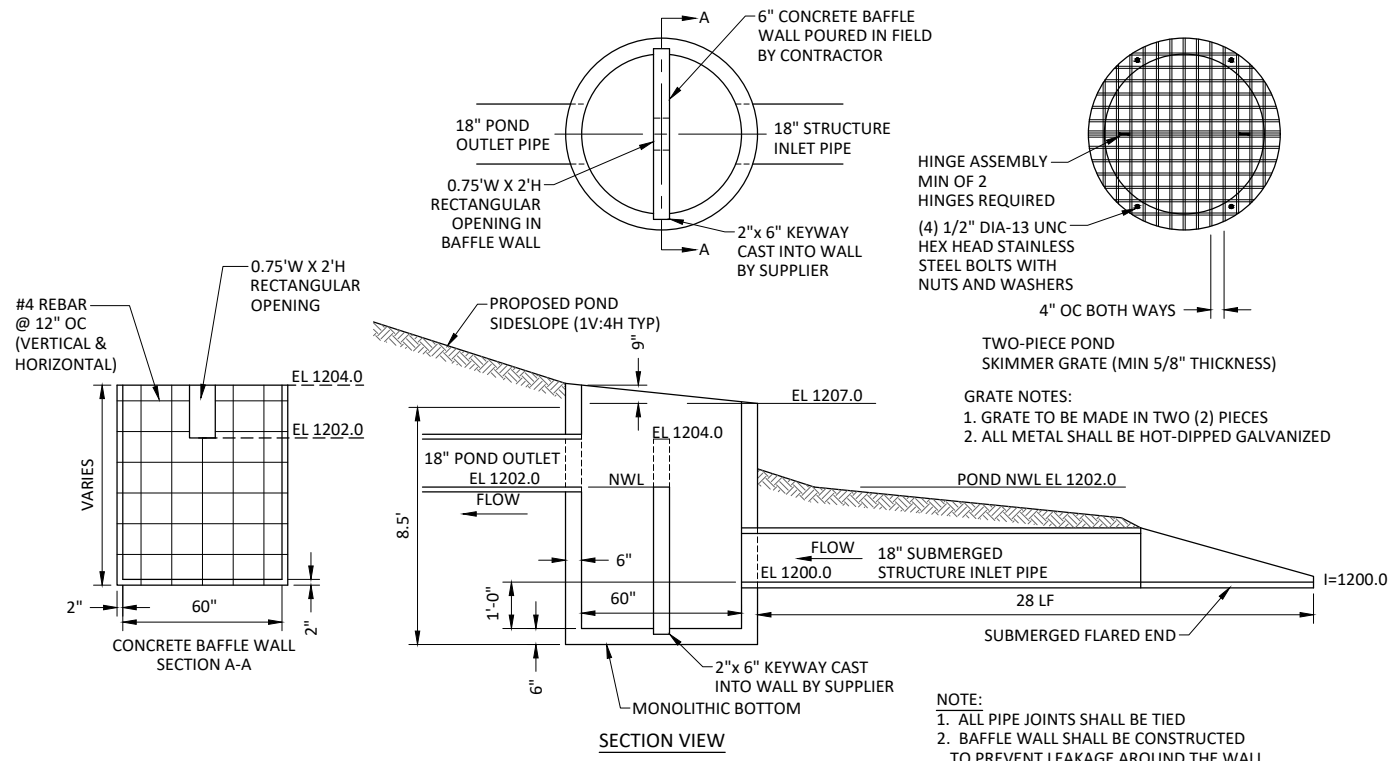

**PRECAST CONCRETE POND SKIMMER STRUCTURE
STRUCTURE SPECIAL 1 (C-3)**
NOT TO SCALE

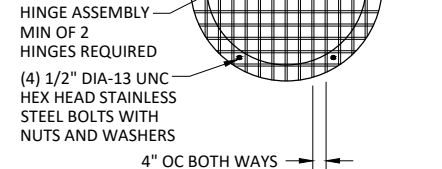

HINGE ASSEMBLY
MIN OF 2 HINGES REQUIRED
(4) 1/2" DIA-13 UNC HEX HEAD STAINLESS STEEL BOLTS WITH NUTS AND WASHERS
4" OC BOTH WAYS

TWO-PIECE POND SKIMMER GRATE (MIN 5/8" THICKNESS)
GRATE NOTES:
1. GRATE TO BE MADE IN TWO (2) PIECES
2. ALL METAL SHALL BE HOT-DIPPED GALVANIZED

NOTE:
1. ALL PIPE JOINTS SHALL BE TIED
2. BAFFLE WALL SHALL BE CONSTRUCTED TO PREVENT LEAKAGE AROUND THE WALL

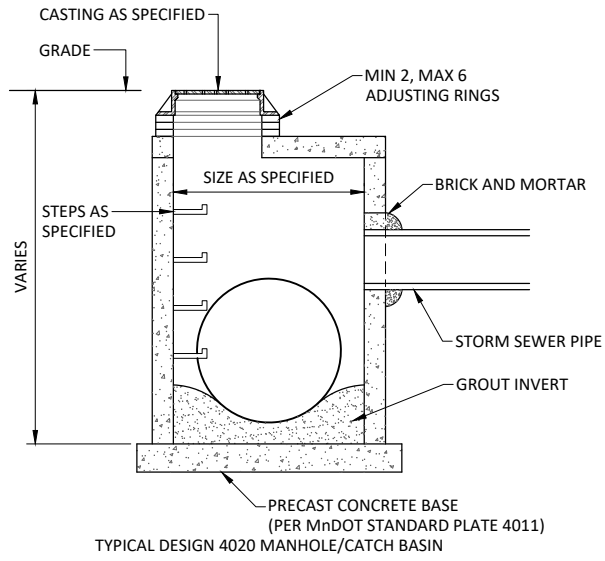

NOTES:
1. AASHTO HS 25 LOADING MAX FILL HEIGHT 15'
2. THE # 4020 SHALL BE PERMANENTLY MARKED ON THE TOP COVER
3. EQUIVALENT STEEL AREAS IN WIRE MESH MAY BE USED
4. REINFORCEMENT PER SPEC 3301, GRADE 60 A SINGLE HOOP OF 8ga STEEL WIRE

DESIGNATION:
DESIGN DIAMETER - STANDARD PLATE #
DESIGN 48-4020

STORM SEWER STRUCTURE DESIGN 4020
NOT TO SCALE

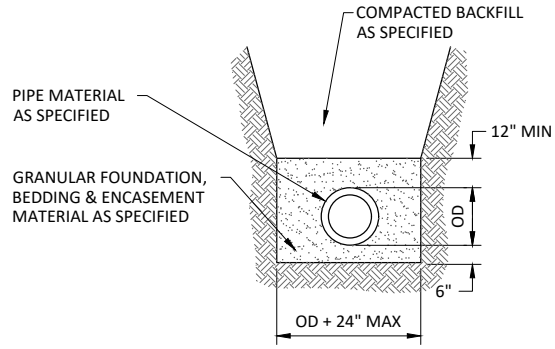
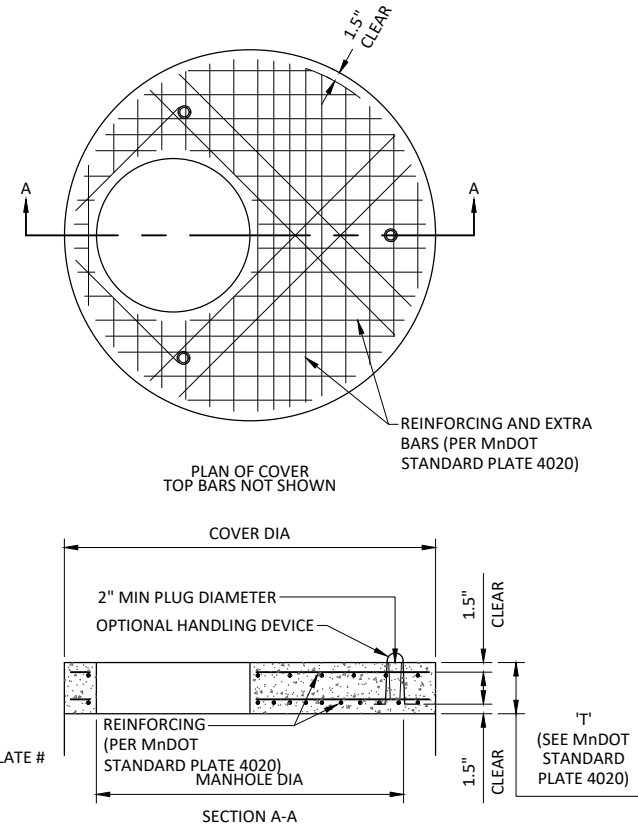

NON-RIGID STORM SEWER TRENCH
NOT TO SCALE

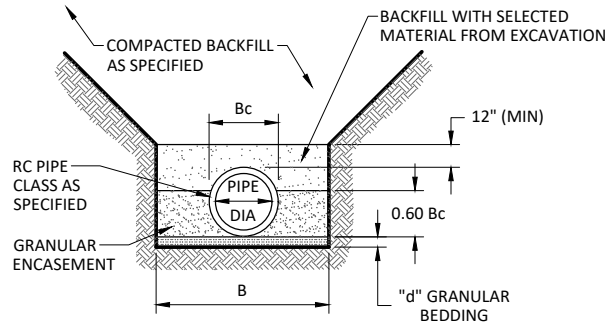

PIPE DIA	d	B
27" OR LESS	3"	Bc + 24"
30" TO 60"	4"	1.5 x Bc
66" OR OVER	6"	Bc + 36"

RC PIPE CLASS "B" BEDDING-SQUARE TRENCH
NOT TO SCALE

© Bolton & Menk, Inc. 2023. All Rights Reserved. A:\PROJECTS_P\191131287\CAD\C3D130187\C3D1.dwg 5/15/2023 7:24:17 AM

I HEREBY CERTIFY THAT THIS PLAN, SPECIFICATION, OR REPORT WAS PREPARED BY ME OR UNDER MY DIRECT SUPERVISION AND THAT I AM A DULY LICENSED PROFESSIONAL ENGINEER UNDER THE LAWS OF THE STATE OF MINNESOTA.
NOT FOR CONSTRUCTION
ALEC W. PIETZ, P.E.
LIC. NO. 59617 DATE XX/XX/XXXX



1960 PREMIER DRIVE
MANKATO, MINNESOTA 56001
Phone: (507) 625-4171
Email: Mankato@bolton-menk.com
www.bolton-menk.com

DESIGNED	NO.	ISSUED FOR	DATE
AWP			
AWP			
CHECKED			
MS			
CLIENT PROJ. NO.	0M1.130187		

KEY CITY GROUP, LLC
FAIRMONT CONTRACTOR CONDOMINIUMS
STORM SEWER DETAILS

SHEET
C1.03

STORMWATER POLLUTION PREVENTION PLAN (SWPPP)

FAIRMONT CONTRACTOR CONDOMINIUMS
CITY OF FAIRMONT
MARTIN COUNTY, MINNESOTA

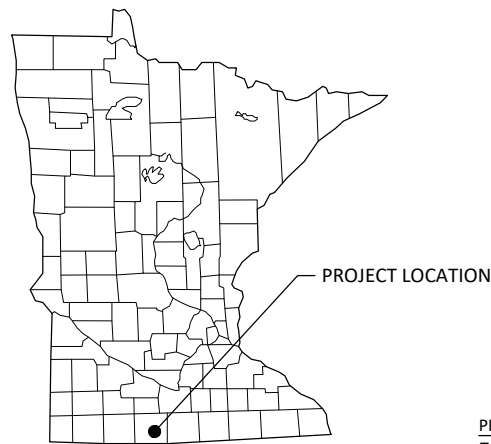

LEGEND

	1-MILE BOUNDARY
	PROJECT BOUNDARY
	NATIONAL WETLANDS INVENTORY

PROJECT AREAS:

Total Project Size (disturbed area) =	6.9	ACRES
Existing area of impervious surface =	0.0	ACRES
Post construction area of impervious surface =	3.8	ACRES
Total new impervious surface area created =	3.8	ACRES

Planned Construction Start Date: July 2023
Estimated Construction Completion Date: TBD

PERMANENT STORMWATER MANAGEMENT SYSTEM:
Type of storm water management used if more than 1 acre of new impervious surface is created:

X	Wet Sedimentation Basin
	Infiltration/Filtration
	Regional Pond
	Permanent Stormwater Management Not Required

PROJECT LOCATION:

COUNTY	TOWNSHIP	RANGE	SECTION	LATITUDE	LONGITUDE
Martin	T102N	R31W	12	43.6577° N	94.5041° W

BMP SUMMARY	QUANTITY	UNIT
STABILIZED CONSTRUCTION EXIT	1	LUMP SUM
PERIMETER CONTROL	2650	LIN FT
SEED MIX 25-141, FERTILIZE, & MULCH	0.35	ACRE
SEED MIX 25-151, FERTILIZE, & MULCH	2.30	ACRE
SEED MIX 33-261, FERTILIZE, & MULCH	0.40	ACRE
EROSION CONTROL BLANKET CATEGORY 20	6050	SQ YD
STORM DRAIN INLET PROTECTION	4	EACH
RANDOM RIPRAP CLASS III	60	CU YD

NOTE: QUANTITIES LISTED ACCOUNT FOR ONE INSTALLATION. ADDITIONAL INSTALLATIONS MAY BE REQUIRED DUE TO MAINTENANCE AND PHASING, THESE ADDITIONAL INSTALLATIONS SHALL BE CONSIDERED INCIDENTAL.

DESCRIPTION OF CONSTRUCTION ACTIVITIES AND STORMWATER MANAGEMENT:

Construction activities include: Road construction, site grading, sanitary sewer and water main installation, pond excavation, storm sewer installation, temporary erosion and sediment control, and permanent stabilization.

Stormwater currently drains by overland flow on farmland in four general directions within the site. An existing tile system west of the site collects a large portion of the stormwater and other areas discharge to public right-of-way, a private site, and other adjacent farmland.

This project will be constructed in multiple phases and an overall stormwater management plan was developed in the full-build scenario. Most of the proposed drainage in the full-build scenario will be routed to the planned pond to treat the stormwater and attenuate the peak flow. The pond will ultimately discharge to the mentioned tile system west of the property.

The listed impervious area with this project includes the currently proposed phase. The anticipated full-build impervious area is approximately 7.9 acres and the pond is sized for this.

A copy of the SWPPP must remain on site at all times. Any modifications to the SWPPP must be approved by the Engineer.

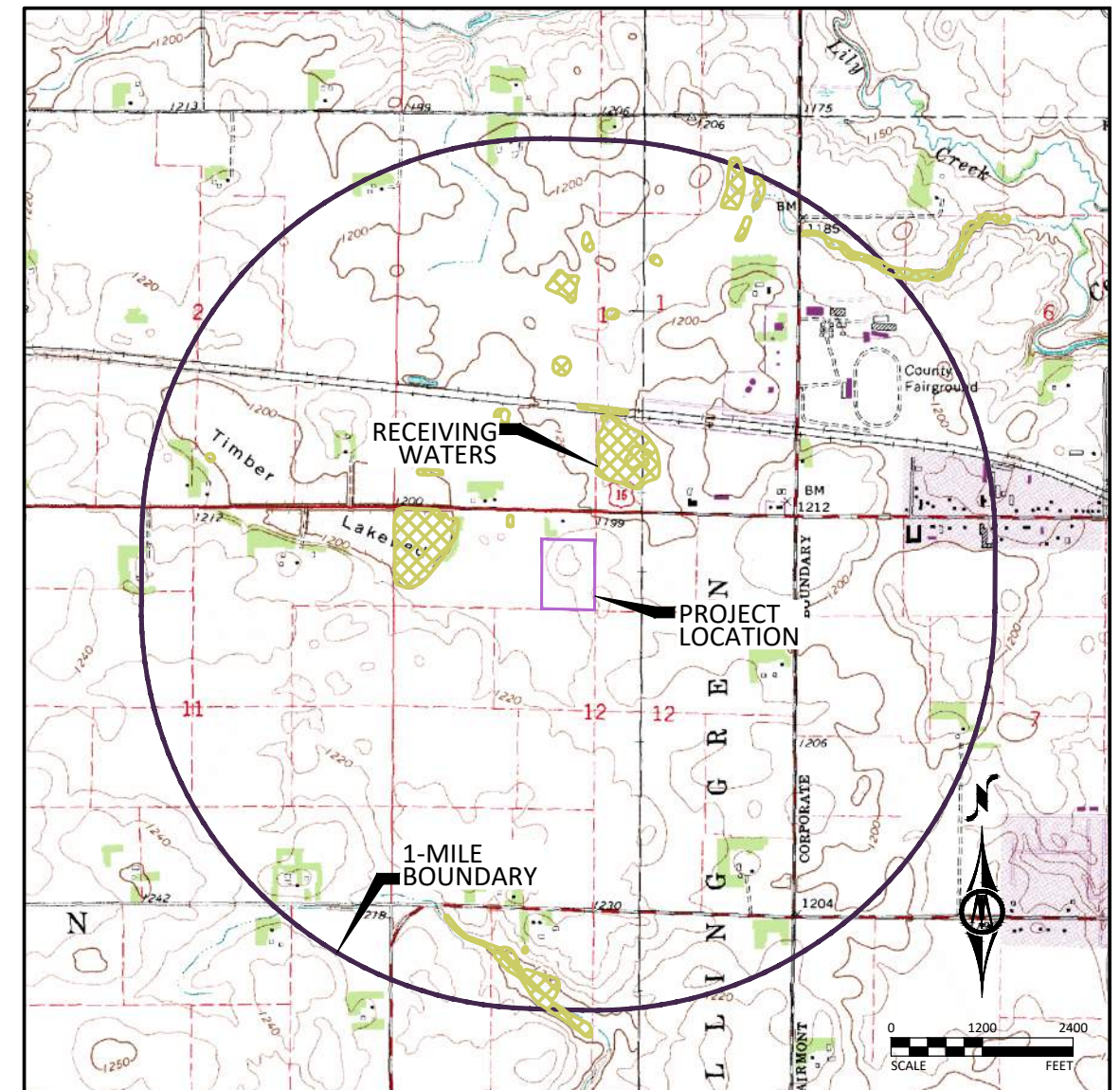

RECEIVING WATERS:
Receiving waters, including surface water, wetlands, Public Waters, and stormwater ponds, within 1-mile of the project boundary are identified on the USGS 7.5 min quad map above. Receiving waters that are impaired, the impairment, and WLA are listed as follows. All specific BMPs relative to construction activities listed in the permit for special, prohibited, restricted, or impaired have been incorporated into this plan. All specific BMPs listed in approved TMDLs and those BMPs listed for construction related waste load allocations have also been incorporated.

NAME OF WATER BODY	TYPE (ditch, pond, wetland, lake, etc.)	Special, Prohibited, Restricted Water ¹	Flows to Impaired Water Within 1-Mile ²	USEPA Approved Construction Related TMDL ³
Unnamed Wetland	Wetland	No	No	N/A

¹ Special, prohibited, and restricted waters are listed in Section 23 of the MN Construction Stormwater General Permit (MNR100001).
² Identified as impaired under section 303 (d) of the federal Clean Water Act for phosphorus, turbidity, TSS, dissolved oxygen, and/or aquatic biota.
³ Construction Related TMDLs include those related to: phosphorus, turbidity, TSS, dissolved oxygen, and/or aquatic biota.

IMPLEMENTATION SCHEDULE AND PHASING: The Contractor is required to provide an updated schedule and site management plan meeting the minimum requirements of Section 1717 of the Minnesota Standard Specifications for Construction.

- 1) Submit SWPPP Updates to Engineer. Submittal shall include any requested changes to the SWPPP, including but not limited to: Trained Personnel, Locations for Stockpiles, Concrete Washout, Sanitation Facilities, Types and Locations of Erosion & Sediment Control. Failure to submit updates shall be considered acceptance of the SWPPP as designed with no changes.
- 2) Install perimeter sediment control, inlet protection, and construction exit.
- 3) Remove existing surfaces as required.
- 4) Complete site and utility improvements.
- 5) Install additional inlet protection as needed.
- 6) Reestablish turf.
- 7) Repeat steps 2-6 as necessary throughout the project.
- 8) Add additional temporary BMPs as necessary during construction based on inspection reports.
- 9) Ensure final stabilization measures are complete.
- 10) Provide digital copy of all Field SWPPP Documentation including Inspection Reports and SWPPP Revisions to the Owner.
- 11) Submit Notice of Termination (NOT) to MPCA. NOTE: The NOT must be submitted to MPCA before Final Stabilization is considered complete.

RESPONSIBLE PARTIES:

The Contractor and Owner will be joint applicants under the MPCA's General Stormwater Permit for Construction Activity as required by the National Pollutant Discharge Elimination System (NPDES) Phase II program.

The Contractor shall provide one or more trained Construction SWPPP Manager(s) knowledgeable and experienced in the application of erosion prevention and sediment control BMPs that will oversee the implementation of the SWPPP, and the installation, inspection and maintenance of the erosion prevention and sediment control BMPs.

A Construction SWPPP Manager must be available for an on-site inspection within 72 hours upon request by the MPCA.

	COMPANY	CONTACT PERSON	PHONE
PRIVATE IMPROVEMENTS OWNER:	Key City Group, LLC	Dan Sprague	507-380-2718
PUBLIC IMPROVEMENTS OWNER:	City of Fairmont	Tyler Cowing	507-238-3948
SWPPP DESIGNER:	Bolton & Menk, Inc.	Alec Pietz, P.E.	507-625-4171
CONTRACTOR:	TBD	TBD	TBD
CONSTRUCTION SWPPP MANAGER:	TBD	TBD	TBD
PARTY RESPONSIBLE FOR LONG TERM O&M (PRIVATE IMPROVEMENTS):	Key City Group, LLC	Dan Sprague	507-380-2718
PARTY RESPONSIBLE FOR LONG TERM O&M (PUBLIC IMPROVEMENTS):	City of Fairmont	Tyler Cowing	507-238-3948

The SWPPP Designer, Construction SWPPP Manager, and BMP Installer must have appropriate training. Documentation showing training commensurate with the job duties and responsibilities is required to be included in the SWPPP prior to any work beginning on the site. Training documentation for the SWPPP Designer is included on the Narrative sheet. The Contractor shall attach training documentation to this SWPPP for the Construction SWPPP Manager and BMP Installer prior to the start of construction. This information shall be kept up to date until the project NOT is filed.

ADDITIONAL COMPENSATION

Payment for all work associated with Erosion and Sediment Control shall be as described in the Project Manual. Unless otherwise authorized by the Owner no additional payment shall be made for any work required to administer and maintain the site erosion and sediment control in compliance with the Minnesota Pollution Control Agency (MPCA) - General Stormwater Permit for Construction Activity (MN R100001) including but not limited to inspection, maintenance, and removal of BMPs or addition of BMPs to accommodate Contractor phasing.

DOCUMENT RETENTION

Permittees must make the SWPPP, including all inspection reports, maintenance records, training records and other information required by this permit, available to federal, state, and local officials within three (3) days upon request for the duration of the permit and for three (3) years following the NOT.

GENERAL STORMWATER DISCHARGE REQUIREMENTS

All requirements listed in Section 5.1 of the Permit for the design of the permanent stormwater management system and discharge have been included in the preparation of this SWPPP. These include but are not limited to:

1. The expected amount, frequency, intensity, and duration of precipitation.
2. The nature of stormwater runoff and run-on at the site
3. Peak flow rates and stormwater volumes to minimize erosion at outlets and downstream channel and stream bank erosion.
4. The range of soil particle sizes expected to be present on the site.

Permanent stormwater treatment systems for this project have been designed in accordance with the guidance in the MN Stormwater Manual in place at the time of bidding. Copies of the design information and calculations are part of this SWPPP and will be provided in digital format upon written request to the Engineer.

I HEREBY CERTIFY THAT THIS PLAN, SPECIFICATION, OR REPORT WAS PREPARED BY ME OR UNDER MY DIRECT SUPERVISION AND THAT I AM A DULY LICENSED PROFESSIONAL ENGINEER UNDER THE LAWS OF THE STATE OF MINNESOTA.

NOT FOR CONSTRUCTION

ALEC W. PIETZ, P.E.
LIC. NO. 59617 DATE XX/XX/XXXX



1960 PREMIER DRIVE
MANKATO, MINNESOTA 56001
Phone: (507) 625-4171
Email: Mankato@bolton-menk.com
www.bolton-menk.com

DESIGNED	NO.	ISSUED FOR	DATE
AWP			
AWP			
MS			
CLIENT PROJ. NO.	0M1.130187		

KEY CITY GROUP, LLC
FAIRMONT CONTRACTOR CONDOMINIUMS
STORMWATER POLLUTION PREVENTION PLAN
PROJECT INFORMATION AND LOCATION MAP

SHEET
C2.01

Information contained in this SWPPP narrative sheet summarizes requirements of the GENERAL PERMIT AUTHORIZATION TO DISCHARGE STORMWATER ASSOCIATED WITH CONSTRUCTION ACTIVITY UNDER THE NATIONAL POLLUTANT DISCHARGE ELIMINATION SYSTEM/STATE DISPOSAL SYSTEM PROGRAM - Permit No: MN RI00001 (Permit) as they apply to this project. All provisions of the Permit including those not specifically cited herein shall apply to this project. The Contractor is responsible to be familiar with and comply with all conditions of the permit. The full text of the Permit is available at: <https://www.pca.state.mn.us/sites/default/files/wq-strm2-80a.pdf>

SWPPP AMENDMENTS AND SUBMITTALS

Contractor must prepare and submit to the Engineer a SWPPP amendment as necessary to include additional Best Management Practices (BMPs) to correct problems identified or address the following situations.

1. Contact information and training documentation for Construction SWPPP Manager and BMP Installer,
2. There is a change in construction method of phasing, operation, maintenance, weather or seasonal conditions not anticipated during the design of the SWPPP including but not limited to:
 - a. Types and/or Locations of BMPs
 - b. Material Storage and Spill Response
 - c. Fueling Plans
 - d. Locations for Stockpiles, Concrete Washout, and Sanitation Facilities and
 - e. Project Phasing
3. It is determined that the SWPPP is not achieving objectives of minimizing pollutants in stormwater discharges associated with construction activity, or
4. The SWPPP is not consistent with the terms and conditions of the permit.

The Contractor may implement SWPPP amendments immediately and is not required to wait for Engineer review of the submittal. The responsibility for completeness of SWPPP amendments and compliance with the Permit lies with the Contractor. Review, comment, or lack of comment by the Engineer on a SWPPP amendment shall not absolve the responsibilities of the Contractor in any way.

If a change order is issued for a design change the SWPPP amendment will be prepared by the Engineer and included in the change order.

In addition to SWPPP amendments, the Contractor shall submit to the Engineer Weekly Erosion and Sediment Control Schedule meeting the requirements of MnDOT 1717.

The Contractor shall keep copies of all SWPPP amendments, Weekly Erosion and Sediment Control Schedules, inspection logs, and maintenance logs with the field copy of the SWPPP. A PDF copy of these documents will be provided along with a copy of the final Field Copy of the SWPPP to the Engineer along with the signed Notice of Termination when final stabilization is complete.

EROSION PREVENTION PRACTICES

Stormwater conveyance channels shall be routed around unstabilized areas. Erosion controls and velocity dissipation devices shall be used at outlets within and along the length of any constructed conveyance channel.

The normal wetted perimeter of all ditches or swales, including storm water management pond slopes, that drain waters from the site must be stabilized within 200' of any property edge or discharge point, including storm sewer inlets, within 24 hours of connection.

Temporary or permanent ditches or swales used as sediment containment during construction do not need to be stabilized during temporary period of use and shall be stabilized within 24 hours after no longer used as sediment containment.

Mulch, hydromulch, tackifier, or similar practice shall not be used in any portion of the wetted perimeter of a temporary or permanent drainage ditch or swale section with a continuous slope of greater than 2 percent.

Energy dissipation shall be installed at all temporary or permanent pipe outlets within 24 hours of connection to a surface water or permanent stormwater treatment system.

The Contractor shall phase construction and use construction methods to the extent practical to minimize exposed soils. The project phasing shall be documented in the Weekly Erosion and Sediment Control Schedule.

SEDIMENT CONTROL PRACTICES

Down gradient BMPs including perimeter BMPs must be in place before up gradient land- disturbing activities begin and shall remain in place until final stabilization.

All BMPs that have been adjusted or removed to accommodate short-term activities shall be re-installed or replaced the earlier of the end of the work day or before the next precipitation event even if the activity is not complete.

Inlet BMPs may be removed for specific safety concerns. The BMPs shall be replaced as soon as the safety concern is resolved. The removal shall be documented in the SWPPP as a SWPPP amendment.

Temporary stockpiles must have sediment control BMPs. The Contractor shall prepare and submit to the Engineer a SWPPP amendment showing the location of temporary stockpiles and the BMPs for each stockpile. The SWPPP amendment must meet the minimum requirements of Section 9 of the Permit.

Soil compaction shall be minimized and topsoil shall be preserved, unless infeasible or if construction activities dictate soil compaction or topsoil stripping.

The use of polymers, flocculants, or other sedimentation treatment chemicals are not proposed as part of this SWPPP as designed by the Engineer. If methods or phasing of construction require the use of any of these chemicals, the Contractor shall prepare and submit to the Engineer a SWPPP amendment that meets the minimum requirements of Section 9 of the Permit.

TEMPORARY SEDIMENTATION BASINS

A temporary sedimentation basin has not been included in this SWPPP as designed by the Engineer. If a basin is later determined to be desirable or necessary the Contractor shall prepare and submit to the Engineer a SWPPP amendment. Temporary sedimentation basins shall meet or exceed the minimum requirements of Section 14 of the Permit and shall include a basin draining plan meeting or exceeding the minimum requirements of Section 10 of the Permit. Where the site discharges to Special and/or Impaired Waters the SWPPP amendment shall also meet or exceed the minimum requirements of Section 23 of the permit.

DEWATERING

A dewatering plan has not been included in this SWPPP as designed by the Engineer. If dewatering is required for this project, the Contractor shall prepare and submit to the Engineer a SWPPP amendment. All dewatering shall meet or exceed the minimum requirements of Section 10 of the Permit.

POLLUTION PREVENTION

Products and materials that have the potential to leach pollutants that are stored on the site must be stored in a manner designed to minimize contact with stormwater. Materials that are not a source of potential contamination to stormwater or that are designed for exposure to stormwater are not required to be covered.

Hazardous materials including but not limited to pesticides, fertilizer, petroleum products, curing compounds and toxic waste must be properly stored and protected from stormwater exposure as recommended by the manufacturer in an access restricted area.

Solid waste must be stored, collected and disposed of in compliance with Minnesota Administrative Rules Chapter 7035.

Portable toilets must be positioned so that they are secure and will not be tipped or knocked over. Sanitary waste must be disposed of properly in accordance with Minn. R. CH 7041.

Exterior vehicle or equipment washing on the project site shall be limited to a defined area of the site. No engine degreasing is allowed on site. A sign must be installed adjacent to each washout facility that requires site personnel to utilize the proper facilities for disposal of concrete and other washout wastes.

The Contractor shall prepare and submit a SWPPP amendment detailing the location and BMPs proposed for storage of materials, solid waste, portable toilets, and exterior vehicle or equipment washing on the site. The SWPPP amendment shall include a spill prevention and response plan that is appropriate for the materials proposed to be on the site. The SWPPP amendment shall meet or exceed the minimum requirements of Section 12 of the Permit.

INSPECTION & MAINTENANCE

A trained person shall routinely inspect the entire construction site at the time interval indicated on this sheet of the SWPPP during active construction and within 24-hours after a rainfall event greater than 0.5 inches in 24 hours. Following an inspection that occurs within 24-hours after a rainfall event, the next inspection must be conducted at the time interval indicated in the Receiving Waters Table found on the SITE PLAN AND INFORMATION SHEET of the SWPPP.

All inspections and maintenance conducted during construction must be recorded on the day it is completed and must be retained with the SWPPP. Inspection report forms are available in the Project Specifications. Inspection report forms other than those provided shall be approved by the engineer.

The Contractor may request a change in inspection schedule for the following conditions:

- a. Inspections of areas with permanent cover to be reduced to once per month,
- b. Inspections of areas that have permanent cover and have had no construction activity for 12 months to be suspended until construction resumes,
- c. Inspections of areas where construction is suspended due to frozen ground conditions, inspections to be suspended until the earlier of within 24 hours of runoff occurring, or upon resuming construction.

No change in inspection schedule shall occur until authorized by the Engineer.

Inspections must include:

1. All erosion prevention and sediment control BMPs and Pollution Prevention Management Measures to ensure integrity and effectiveness.
2. Surface waters, including drainage ditches and conveyance systems for evidence of erosion and sediment deposition.
3. Construction site vehicle exit locations, streets and curb and gutter systems within and adjacent to the project for sedimentation from erosion or tracked sediment from vehicles.
4. Infiltration areas to ensure that no sediment from ongoing construction activity is reaching the infiltration area and that equipment is not being driven across the infiltration area.

All non-functioning BMPs and those BMPs where sediment reaches one-half (1/2) of the depth of the BMP, or in the case of sediment basins one-half (1/2) of the storage volume, must be repaired, replaced, or supplemented by the end of the next business day after discovery, or as soon as field conditions allow.

Permittees must repair, replace or supplement all nonfunctional BMPs with functional BMPs by the end of the next business day after discovery, or as soon as field conditions allow.

Any sediment that escapes the site must be removed and the area stabilized within 7 calendar days of discovery unless precluded by legal, regulatory, or physical access in which case the work shall be completed within 7 calendar days of authorization. Paved surfaces such as streets shall have any escaped or tracked sediment removed by the end of the day that it is discovered. Sediment release, other than paved surfaces that can be cleaned up with street sweeping shall be reported immediately upon discovery to the Engineer.

PUBLIC WATER RESTRICTIONS:

For public waters that have been promulgated "work in water restrictions" during fish spawning time frames, all exposed soil areas that are within 200 feet of the water's edge, and drain to these waters must complete stabilization within 24-hours during the time period. MN DNR permits are not valid for work in waters that are designated as infested waters unless accompanied by an Infested Waters Permit or written notification has been obtained from MN DNR stating that such permit is not required. There is no exception for pre-existing permits. If a MN DNR Permit has been issued for the project and the water is later designated as infested, the Contractor shall halt all work covered by the MN DNR Permit until an Infested Waters Permit is obtained or that written notification is obtained stating that such permit is not required.

FINAL STABILIZATION

Final Stabilization is not complete until all the following requirements have been met:

1. Substantial Completion has been reached and no ground disturbing activities are anticipated.
2. Permanent cover has been installed with an established minimum uniform perennial vegetation density of 70 percent of its expected final growth. Vegetation is not required in areas where no vegetation is proposed by this project such as impervious surfaces or the base of a sand filter.

3. Accumulated sediment has been removed from all permanent stormwater treatment systems as necessary to ensure the system is operating as designed.
4. All sediment has been removed from conveyance systems
5. All temporary synthetic erosion prevention and sediment control BMPs have been removed. BMPs designated on the SWPPP to remain to decompose on-site may remain.
6. For residential construction only, permit coverage terminates on individual lots if the structures are finished and temporary erosion prevention and downgradient perimeter control is complete, the residence sells to the homeowner, and the permittee distributes the MPCA's "Homeowner Fact Sheet" to the homeowner.
7. For agricultural land only (e.g., pipelines across cropland), the disturbed land must be returned to its preconstruction agricultural use prior to submitting the NOT.

SITE STABILIZATION COMPLETION:

Stabilization of exposed soils shall begin immediately and shall be completed after the construction activity has temporarily or permanently ceased no later than:	14 calendar days
--	------------------

SITE INSPECTION INTERVAL:

A trained person shall routinely inspect the entire construction site during active construction at an interval of no more than:	7 calendar days
--	-----------------

SPECIAL ENVIRONMENTAL CONSIDERATIONS AND PERMITS:

1)	Was an environmental review required for this project or any part of a common plan of development or sale that includes all or any portion of this project?	NO
2)	Does any portion of the site have the potential to affect threatened or endangered species or their critical habitat?	NO
3)	Does any portion of this site discharge to a Calcareous fen.	NO
4)	Will any portion of the site potentially affect properties listed on the National Register of Historic Places or a known or discovered archeological site?	NO
5)	Have any Karst features have been identified in the project vicinity?	NO
6)	Is compliance with temporary or permanent stormwater management design requirements infeasible for this project?	NO
7)	Has the MN DNR promulgated "work in water restrictions" for any Public Water this site discharges to during fish spawning?	NO

SWPPP DESIGNER TRAINING DOCUMENTATION:

UNIVERSITY OF MINNESOTA

Alec W. Pietz

Construction Site Management (May 31 2024)
Design of Construction SWPPP (May 31 2024)

© Bolton & Menk, Inc. 2023. All Rights Reserved. A:\MECTIC\B_P\BWA\330287\CAD\CAD130187\CD01.dwg 12/19/2023 7:24:31 AM

I HEREBY CERTIFY THAT THIS PLAN, SPECIFICATION, OR REPORT WAS PREPARED BY ME OR UNDER MY DIRECT SUPERVISION AND THAT I AM A DULY LICENSED PROFESSIONAL ENGINEER UNDER THE LAWS OF THE STATE OF MINNESOTA.
NOT FOR CONSTRUCTION
ALEC W. PIETZ, P.E.
LIC. NO. 59617 DATE XX/XX/XXXX



1960 PREMIER DRIVE
MANKATO, MINNESOTA 56001
Phone: (507) 625-4171
Email: Mankato@bolton-menk.com
www.bolton-menk.com

DESIGNED	NO.	ISSUED FOR	DATE
AWP			
AWP			
CHECKED			
MS			
CLIENT PROJ. NO.			
0M1.130187			

KEY CITY GROUP, LLC
FAIRMONT CONTRACTOR CONDOMINIUMS
STORMWATER POLLUTION PREVENTION PLAN
NARRATIVE

SHEET

C2.02

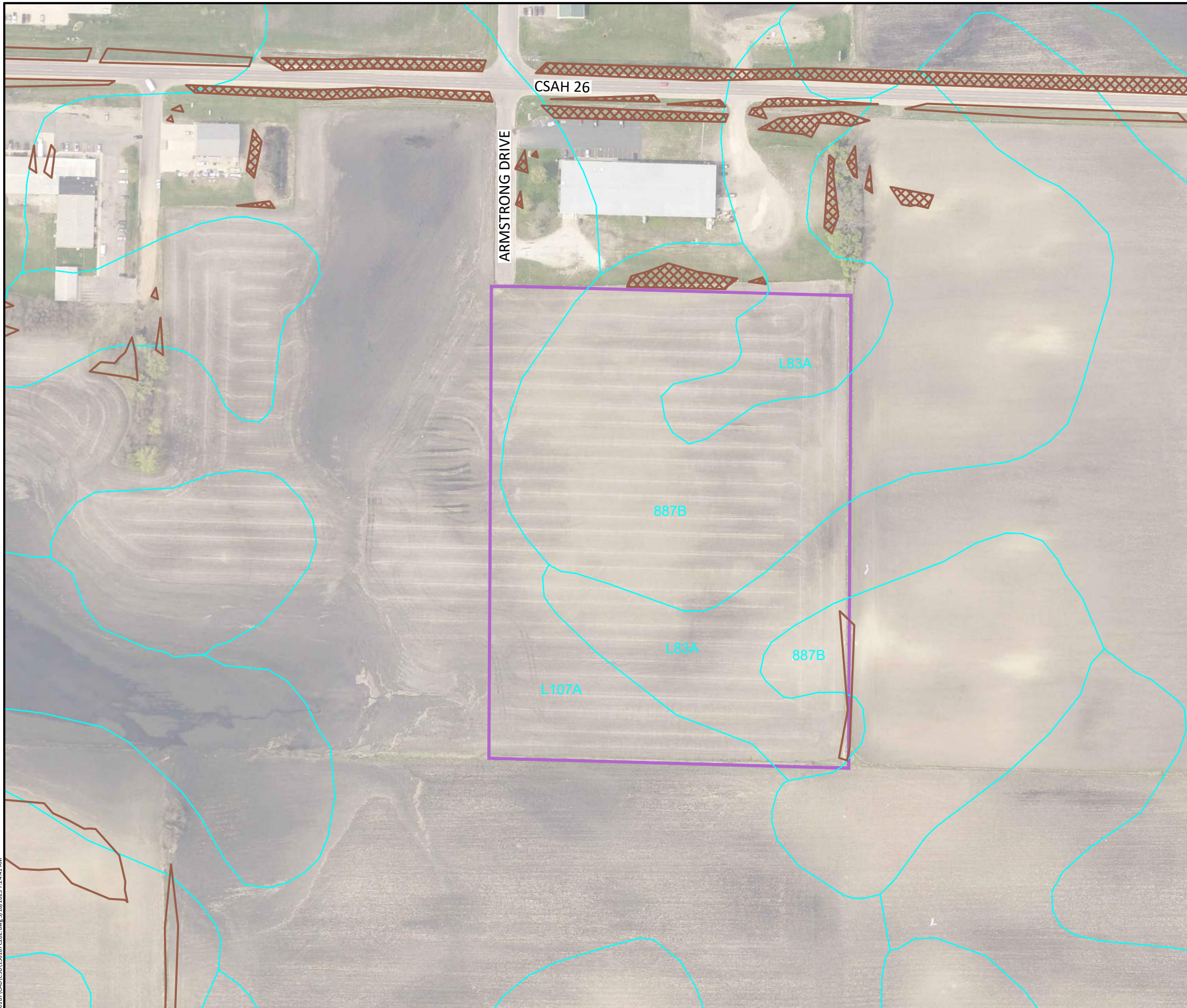

LEGEND

- PROJECT BOUNDARY
- SOIL TYPE
- STEEP SLOPES (>33.3%)



SOIL TYPE SUMMARY

Map Unit Symbol	Soil Name	Hyd. Soil Group	Erodibility
MUSYM	MUNAME	HYDGRP	MUHELCL
L83A	Webster clay loam, 0 to 2 percent slopes	C/D	NHEL
L107A	Canisteo-Glencoe, depressional complex, 0 to 2 percent slopes	C/D	NHEL
887B	Clarion-Swanlake loams, 2 to 6 percent slopes	C	NHEL

NHEL - Not Highly Erodible Land
 PHEL - Potentially Highly Erodible Land
 HEL - Highly Erodible Land

LOCATION OF SWPPP REQUIREMENTS IN PROJECT PLAN

DESCRIPTION	SHEET NO.
SITE MAP	C2.01
NARRATIVE & NOTES	C2.01 - C2.02
SOILS	C2.03
EROSION & SEDIMENT CONTROL DETAILS	C2.04 - C2.05
DIRECTION OF FLOW	C2.06 - C2.07
FINAL STABILIZATION	C2.06 - C2.07

I HEREBY CERTIFY THAT THIS PLAN, SPECIFICATION, OR REPORT WAS PREPARED BY ME OR UNDER MY DIRECT SUPERVISION AND THAT I AM A DULY LICENSED PROFESSIONAL ENGINEER UNDER THE LAWS OF THE STATE OF MINNESOTA.
NOT FOR CONSTRUCTION
 ALEC W. PIETZ, P.E.
 LIC. NO. 59617 DATE XX/XX/XXXX



1960 PREMIER DRIVE
 MANKATO, MINNESOTA 56001
 Phone: (507) 625-4171
 Email: Mankato@bolton-menk.com
 www.bolton-menk.com

DESIGNED	NO.	ISSUED FOR	DATE
AWP			
DRAWN			
CHECKED			
MS			
CLIENT PROJ. NO.	0M1-130187		

KEY CITY GROUP, LLC
 FAIRMONT CONTRACTOR CONDOMINIUMS
 STORMWATER POLLUTION PREVENTION PLAN
 SITE AND SOILS MAP

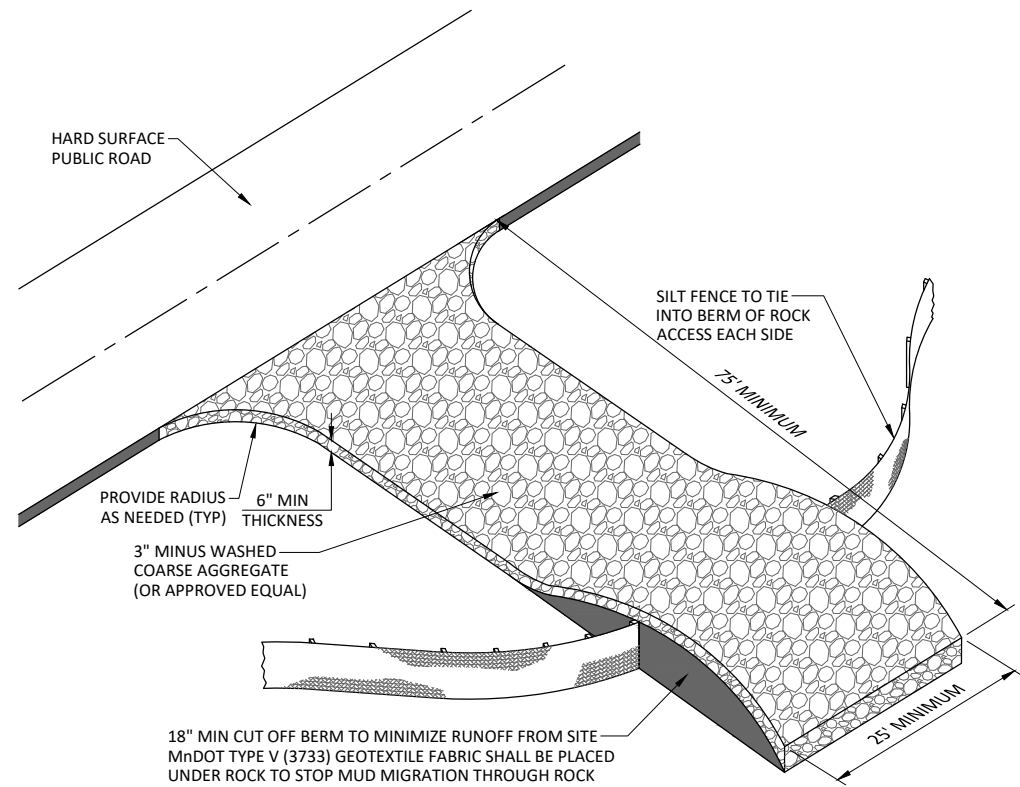

ROCK CONSTRUCTION ENTRANCE
NOT TO SCALE

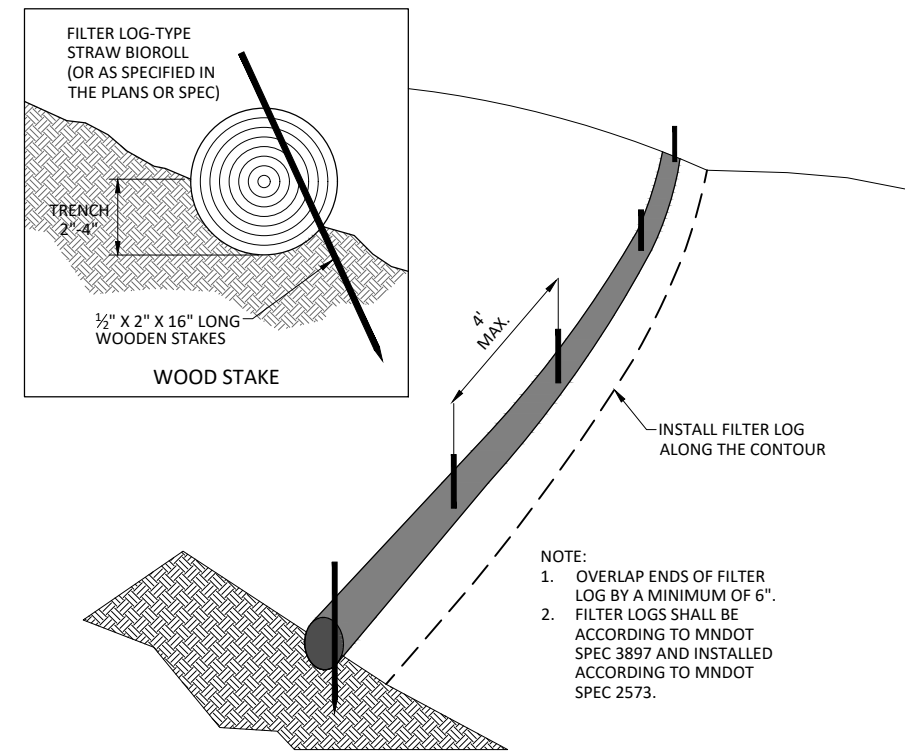

PERIMETER PROTECTION-FILTER LOG
NOT TO SCALE

NOTES:

1. FILTER AGGREGATE TO BE 1 TO 2 INCH CLEAN ROCK
2. FILTER FABRIC SHALL MEET MnDOT SPECIFICATION 3733 GEOTEXTILE FABRIC TYPE II

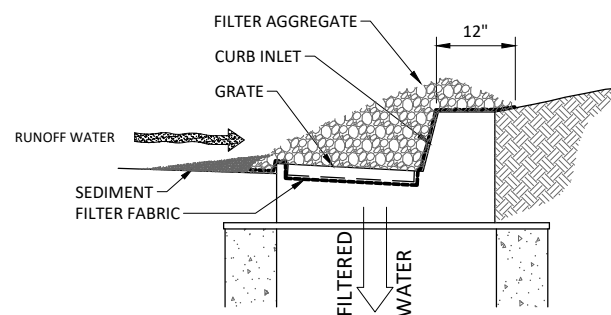

INLET PROTECTION FILTER AGGREGATE
NOT TO SCALE

INLET SPECIFICATIONS AS PER THE PLAN DIMENSION LENGTH AND WIDTH TO MATCH

GEOTEXTILE FABRIC, TYPE WOVEN MONOFILAMENT CONFORMING TO SPEC. 3886, TABLE 3886-1 MACHINE SLICE

FRONT, BACK AND BOTTOM TO BE MADE FROM SINGLE PIECE OF FABRIC

4"x6" OVAL HOLE SHALL BE HEAT CUT INTO ALL FOUR SIDE PANELS

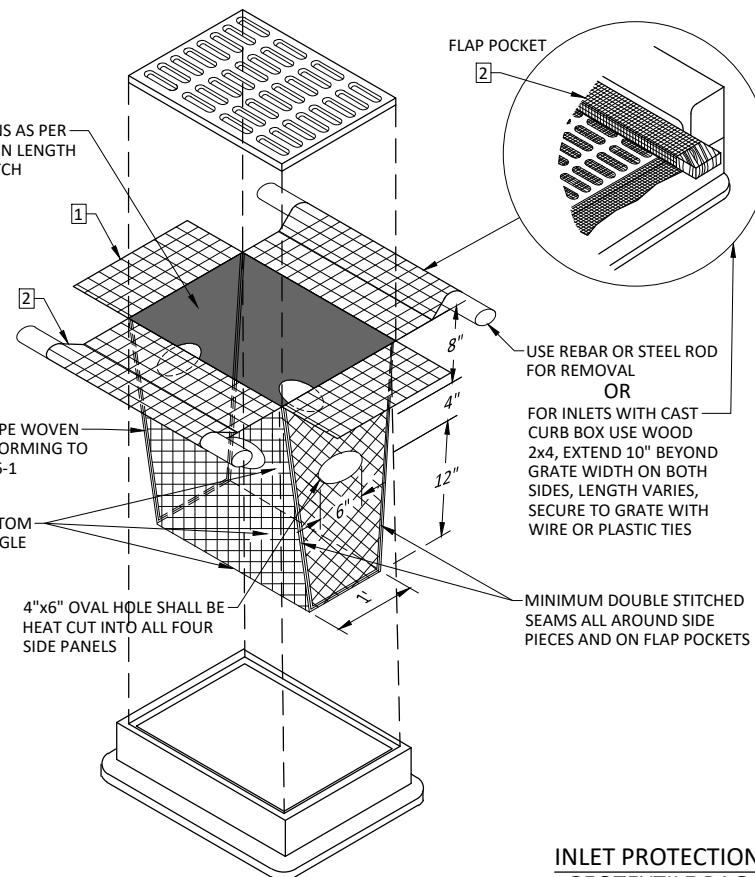

INLET PROTECTION GEOTEXTILE BAG
NOT TO SCALE

NOTES:

1. INLET PROTECTION DEVICES SHALL BE MAINTAINED OR REPLACED AT THE DIRECTION OF THE ENGINEER. MANUFACTURED ALTERNATIVES APPROVED AND LISTED ON THE DEPARTMENTS EROSION CONTROL PRODUCT ACCEPTABILITY LIST MAY BE SUBSTITUTED. WHEN REMOVING OR MAINTAINING INLET PROTECTION, CARE SHALL BE TAKEN SO THAT THE SEDIMENT TRAPPED ON THE GEOTEXTILE FABRIC DOES NOT FALL IN THE INLET. ANY MATERIAL FALLING INTO THE INLET SHALL BE REMOVED IMMEDIATELY.
2. FINISHED SIZE, INCLUDING POCKETS WHERE REQUIRED, SHALL EXTEND A MINIMUM OF 10" AROUND THE PERIMETER TO FACILITATE MAINTENANCE OR REMOVAL.

FLAP POCKETS SHALL BE LARGE ENOUGH TO ACCEPT WOOD 2x4.

INSTALLATION NOTES:
DO NOT INSTALL PROTECTION IN INLETS SHALLOWER THAN 30", MEASURED FROM THE BOTTOM OF THE INLET TO THE TOP OF THE GRATE.

TRIM EXCESS FABRIC IN THE FLOW LINE TO WITHIN 3" OF THE GRATE.

THE INSTALLED BAG SHALL HAVE A MINIMUM SIDE CLEARANCE, BETWEEN THE INLET AND THE BAG, MEASURED AT THE BOTTOM OF THE OVERFLOW HOLES, OF 3". WHERE NECESSARY THE CONTRACTOR SHALL CLINCH THE BAG, USING PLASTIC ZIP TIES, TO ACHIEVE THE 3" CLEARANCE. THE TIES SHALL BE PLACED AT A MAXIMUM OF 4" FROM THE BOTTOM OF THE BAG.

I HEREBY CERTIFY THAT THIS PLAN, SPECIFICATION, OR REPORT WAS PREPARED BY ME OR UNDER MY DIRECT SUPERVISION AND THAT I AM A DULY LICENSED PROFESSIONAL ENGINEER UNDER THE LAWS OF THE STATE OF MINNESOTA.
NOT FOR CONSTRUCTION
ALEC W. PIETZ, P.E.
LIC. NO. 59617 DATE XX/XX/XXXX



1960 PREMIER DRIVE
MANKATO, MINNESOTA 56001
Phone: (507) 625-4171
Email: Mankato@bolton-menk.com
www.bolton-menk.com

DESIGNED	NO.	ISSUED FOR	DATE
AWP			
DRAWN			
AWP			
CHECKED			
MS			
CLIENT PROJ. NO.	0M1.130187		

KEY CITY GROUP, LLC
FAIRMONT CONTRACTOR CONDOMINIUMS
STORMWATER POLLUTION PREVENTION PLAN
BEST MANAGEMENT PRACTICE DETAILS

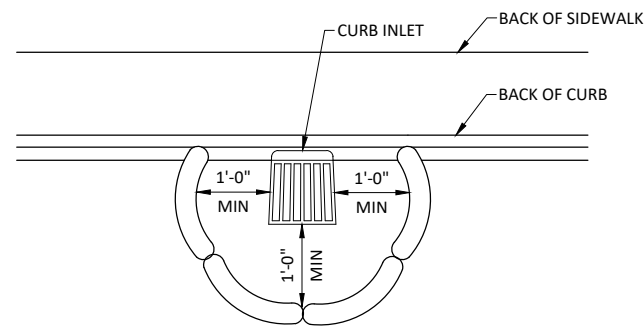

NOTE:
THIS INLET PROTECTION IS USED DURING
ROUGH GRADING ONLY, USE BEFORE ROAD
IS OPEN TO TRAFFIC OR IS PAVED

PAYMENT SHALL INCLUDE ALL MATERIALS,
FILLING OF LOG, PLACEMENT,
MAINTENANCE & REMOVAL;
80% OF BID PRICE SHALL BE PAID UPON
PROPER PLACEMENT WITH THE FINAL 20%
PAID UPON REMOVAL

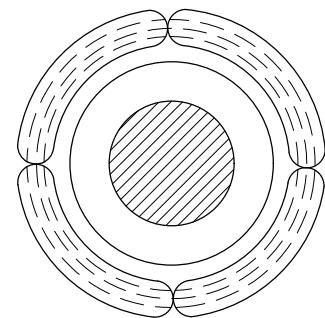

INLET PROTECTION
WITH ROCK LOG

FILL ROCK LOG WITH 45 LBS. OF OPEN
GRADED AGGREGATE CONSISTING OF
SOUND, DURABLE PARTICLES OF CRUSHED
QUARRY ROCK OR GRAVEL CONFORMING
TO THE FOLLOWING GRADATION.

GRADATION	
SIEVE SIZE	PERCENT PASSING
1 1/2"	100
1"	95-100
3/4"	65-95
3/8"	30-65
NO 4	10-35
NO 10	3-20
NO 40	0-8
NO 200	0-3

NOTE:
CRUSHED CONCRETE OR BITUMINOUS
SHALL NOT BE USED FOR OPEN
GRADED AGGREGATE.

ENDS SECURELY CLOSED TO
PREVENT LOSS OF OPEN
GRADED AGGREGATE FILL,
SECURED WITH 50 PSI ZIP TIE

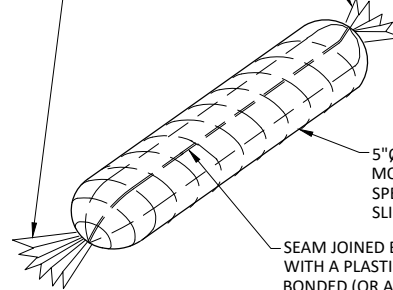

5"Ø GEOTEXTILE SOCK, TYPE WOVEN
MONOFILAMENT CONFORMING TO
SPEC. 3886 TABLE 3886-1. MACHINE
SLICE

SEAM JOINED BY TWO ROWS OF STITCHING
WITH A PLASTIC MESH BACKING OR HEAT
BONDED (OR APPROVED EQUAL)

INLET PROTECTION
ROCK BAG
NOT TO SCALE

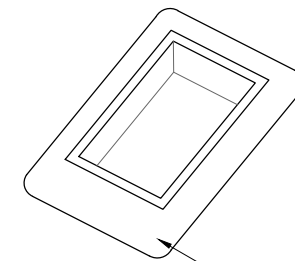

PLACE BARRIER FRAME
ATOP PRE-CAST TOP SLAB

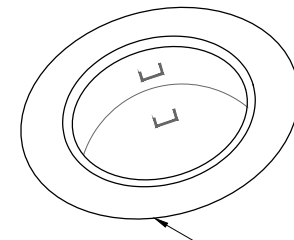

PLACE BARRIER FRAME
ATOP PRE-CAST TOP SLAB

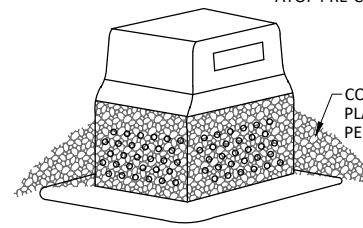

COARSE FILTER AGGREGATE
PLACED TO COVER
PERFORATIONS

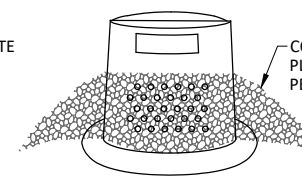

COARSE FILTER AGGREGATE
PLACED TO COVER
PERFORATIONS

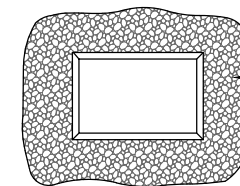

TOP VIEW

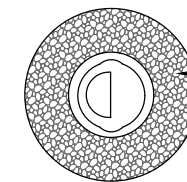

TOP VIEW

COARSE FILTER AGGREGATE
PLACED TO COVER
PERFORATIONS

COARSE FILTER AGGREGATE
PLACED TO COVER
PERFORATIONS

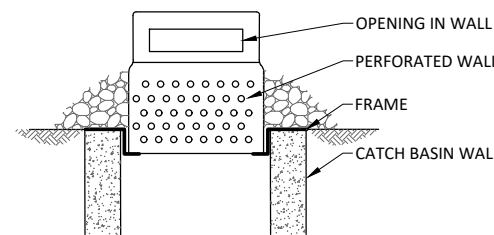

OPENING IN WALL
PERFORATED WALL
FRAME
CATCH BASIN WALL

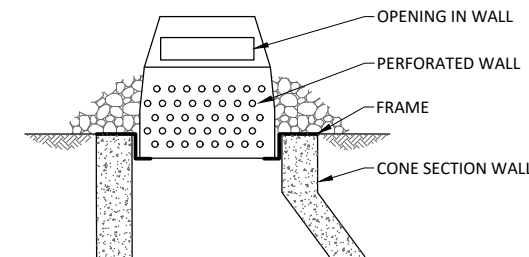

OPENING IN WALL
PERFORATED WALL
FRAME
CONE SECTION WALL

INLET PROTECTION
PERFORATED WALL
NOT TO SCALE

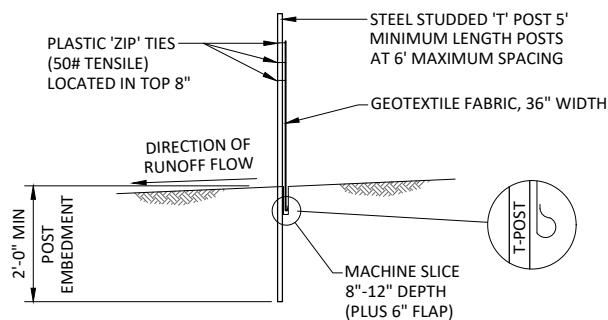

PLASTIC 'ZIP' TIES
(50# TENSILE)
LOCATED IN TOP 8"

STEEL STUDDED 'T' POST 5"
MINIMUM LENGTH POSTS
AT 6' MAXIMUM SPACING

GEOTEXTILE FABRIC, 36" WIDTH

DIRECTION OF
RUNOFF FLOW

2'-0" MIN
POST
EMBEDMENT

MACHINE SLICE
8"-12" DEPTH
(PLUS 6" FLAP)

T-POST

SILT FENCE - MACHINE SLICED
NOT TO SCALE

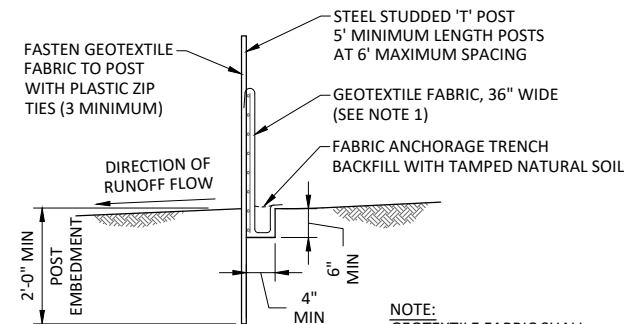

FASTEN GEOTEXTILE
FABRIC TO POST
WITH PLASTIC ZIP
TIES (3 MINIMUM)

STEEL STUDDED 'T' POST
5" MINIMUM LENGTH POSTS
AT 6' MAXIMUM SPACING

GEOTEXTILE FABRIC, 36" WIDE
(SEE NOTE 1)

FABRIC ANCHORAGE TRENCH
BACKFILL WITH TAMPED NATURAL SOIL

DIRECTION OF
RUNOFF FLOW

2'-0" MIN
POST
EMBEDMENT

6" MIN

4" MIN

NOTE:
GEOTEXTILE FABRIC SHALL
BE PER MNDOT SPEC 3886

SILT FENCE - HEAVY DUTY
NOT TO SCALE

© Bolton & Menk, Inc. 2023. All Rights Reserved. A:\PROJECTS_P\1013187\CADD\C3D1301871202.dwg 12/15/2023 7:24:43 AM

I HEREBY CERTIFY THAT THIS PLAN, SPECIFICATION, OR REPORT WAS PREPARED
BY ME OR UNDER MY DIRECT SUPERVISION AND THAT I AM A DULY LICENSED
PROFESSIONAL ENGINEER UNDER THE LAWS OF THE STATE OF MINNESOTA.

NOT FOR CONSTRUCTION

ALEC W. PIETZ, P.E.
LIC. NO. 59617 DATE XX/XX/XXXX



1960 PREMIER DRIVE
MANKATO, MINNESOTA 56001
Phone: (507) 625-4171
Email: Mankato@bolton-menk.com
www.bolton-menk.com

DESIGNED	NO.	ISSUED FOR	DATE
AWP			
AWP			
CHECKED			
MS			
CLIENT PROJ. NO.	0M1.130187		

KEY CITY GROUP, LLC
FAIRMONT CONTRACTOR CONDOMINIUMS
STORMWATER POLLUTION PREVENTION PLAN
BEST MANAGEMENT PRACTICE DETAILS

SHEET
C2.05

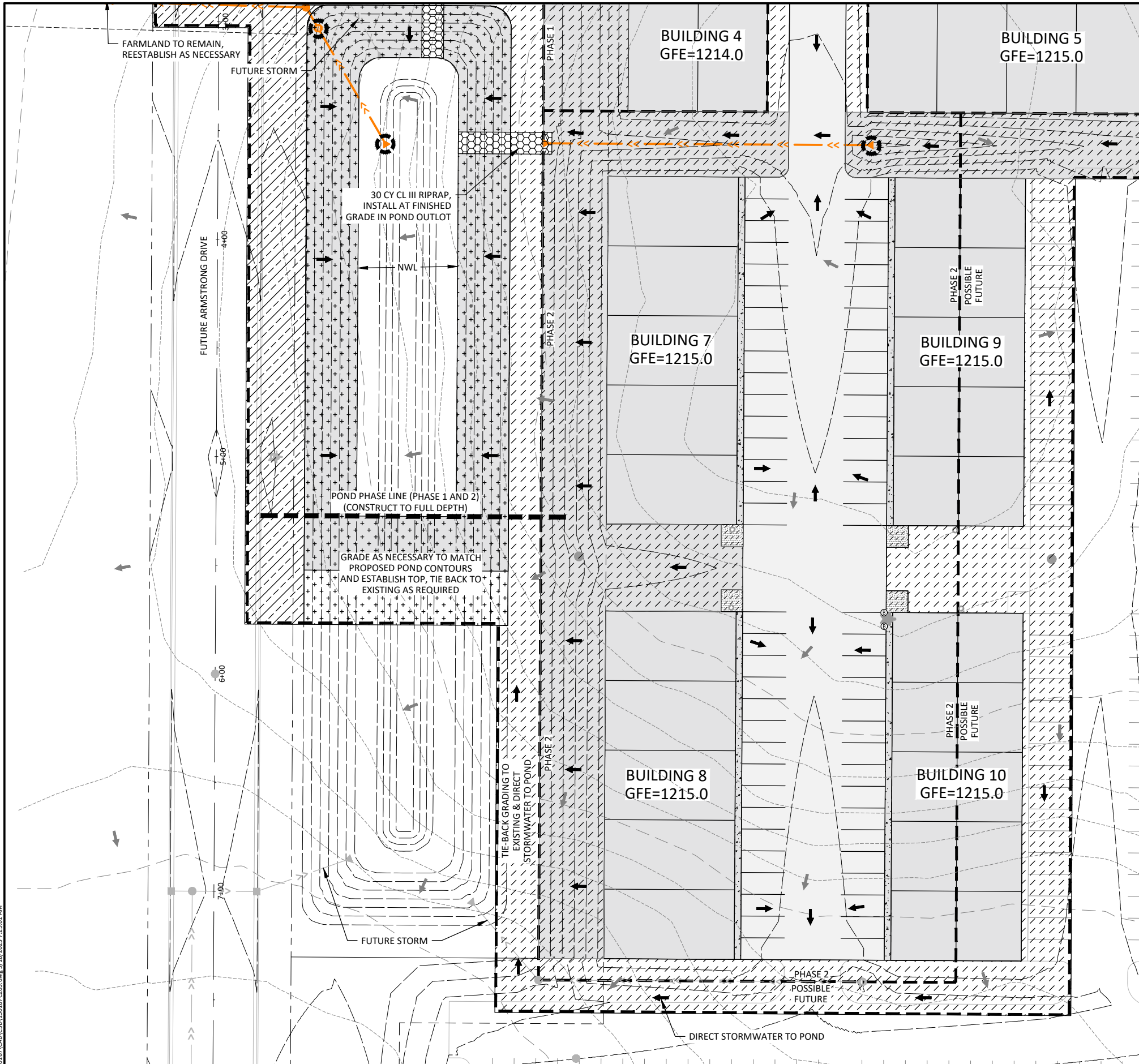

EROSION CONTROL LEGEND	
	EXISTING/PROPOSED DRAINAGE FLOW
	PERIMETER CONTROL
	STABILIZED CONSTRUCTION EXIT
	STORM DRAIN INLET PROTECTION
	SEED MIX 25-151, FERTILIZE, & MULCH
	SEED MIX 33-261, FERTILIZE, & MULCH
	SEED MIX 25-141, FERTILIZE, & MULCH
	EROSION CONTROL BLANKET CATEGORY 20

- NOTES:
- ALL NECESSARY BMP'S SHALL BE IN PLACE PRIOR TO THE START OF CONSTRUCTION. ALL BMP'S SHALL BE INSPECTED EVERY 7 DAYS AND WITHIN 72 HOURS AFTER A RAINFALL EVENT GREATER THAN 0.5 INCHES IN A 24 HOUR PERIOD. ALL NON FUNCTIONING BMP'S SHALL BE REPAIRED OR REPLACED WITHIN 24 HOURS OF DISCOVERY.
 - ALL STORM SEWER INLETS SHALL HAVE INLET PROTECTION IN PLACE AS NEEDED UNTIL DISTURBED TURF IS STABILIZED.
 - ALL PERIMETER CONTROL IS TO BE REMOVED UPON ESTABLISHED TURF RESTORATION.
 - CONTRACTOR TO COORDINATE THE REMOVAL AND REPLACEMENT OF TEMPORARY ROCK CONSTRUCTION EXITS DURING CONSTRUCTION.



© Bolton & Menk, Inc. 2023. All Rights Reserved. A:\MFC\1175_P\1175_P\1175_P\1175_P.dwg 1/19/2023 7:25:01 AM

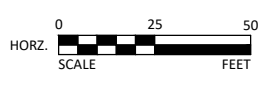

I HEREBY CERTIFY THAT THIS PLAN, SPECIFICATION, OR REPORT WAS PREPARED BY ME OR UNDER MY DIRECT SUPERVISION AND THAT I AM A DULY LICENSED PROFESSIONAL ENGINEER UNDER THE LAWS OF THE STATE OF MINNESOTA.
NOT FOR CONSTRUCTION
 ALEC W. PIETZ P.E.
 LIC. NO. 59617 DATE XX/XX/XXXX



1960 PREMIER DRIVE
 MANKATO, MINNESOTA 56001
 Phone: (507) 625-4171
 Email: Mankato@bolton-menk.com
 www.bolton-menk.com

DESIGNED	NO.	ISSUED FOR	DATE
AWP			
DRAWN			
AWP			
CHECKED			
MS			
CLIENT PROJ. NO.	0M1.130187		







KEY CITY GROUP, LLC
 FAIRMONT CONTRACTOR CONDOMINIUMS
 STORMWATER POLLUTION PREVENTION PLAN
 EROSION & SEDIMENT CONTROL PLAN

SHEET
C2.06

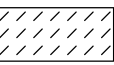
NOTES:

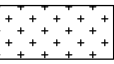
1. ALL NECESSARY BMP'S SHALL BE IN PLACE PRIOR TO THE START OF CONSTRUCTION. ALL BMP'S SHALL BE INSPECTED EVERY 7 DAYS AND WITHIN 72 HOURS AFTER A RAINFALL EVENT GREATER THAN 0.5 INCHES IN A 24 HOUR PERIOD. ALL NON FUNCTIONING BMP'S SHALL BE REPAIRED OR REPLACED WITHIN 24 HOURS OF DISCOVERY.
2. ALL STORM SEWER INLETS SHALL HAVE INLET PROTECTION IN PLACE AS NEEDED UNTIL DISTURBED TURF IS STABILIZED.
3. ALL PERIMETER CONTROL IS TO BE REMOVED UPON ESTABLISHED TURF RESTORATION.
4. CONTRACTOR TO COORDINATE THE REMOVAL AND REPLACEMENT OF TEMPORARY ROCK CONSTRUCTION EXITS DURING CONSTRUCTION.

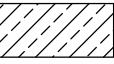
EROSION CONTROL LEGEND

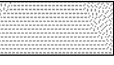
	EXISTING/PROPOSED DRAINAGE FLOW		SEED MIX 25-151, FERTILIZE, & MULCH
	PERIMETER CONTROL		SEED MIX 33-261, FERTILIZE, & MULCH
	STABILIZED CONSTRUCTION EXIT		SEED MIX 25-141, FERTILIZE, & MULCH
	STORM DRAIN INLET PROTECTION		EROSION CONTROL BLANKET CATEGORY 20

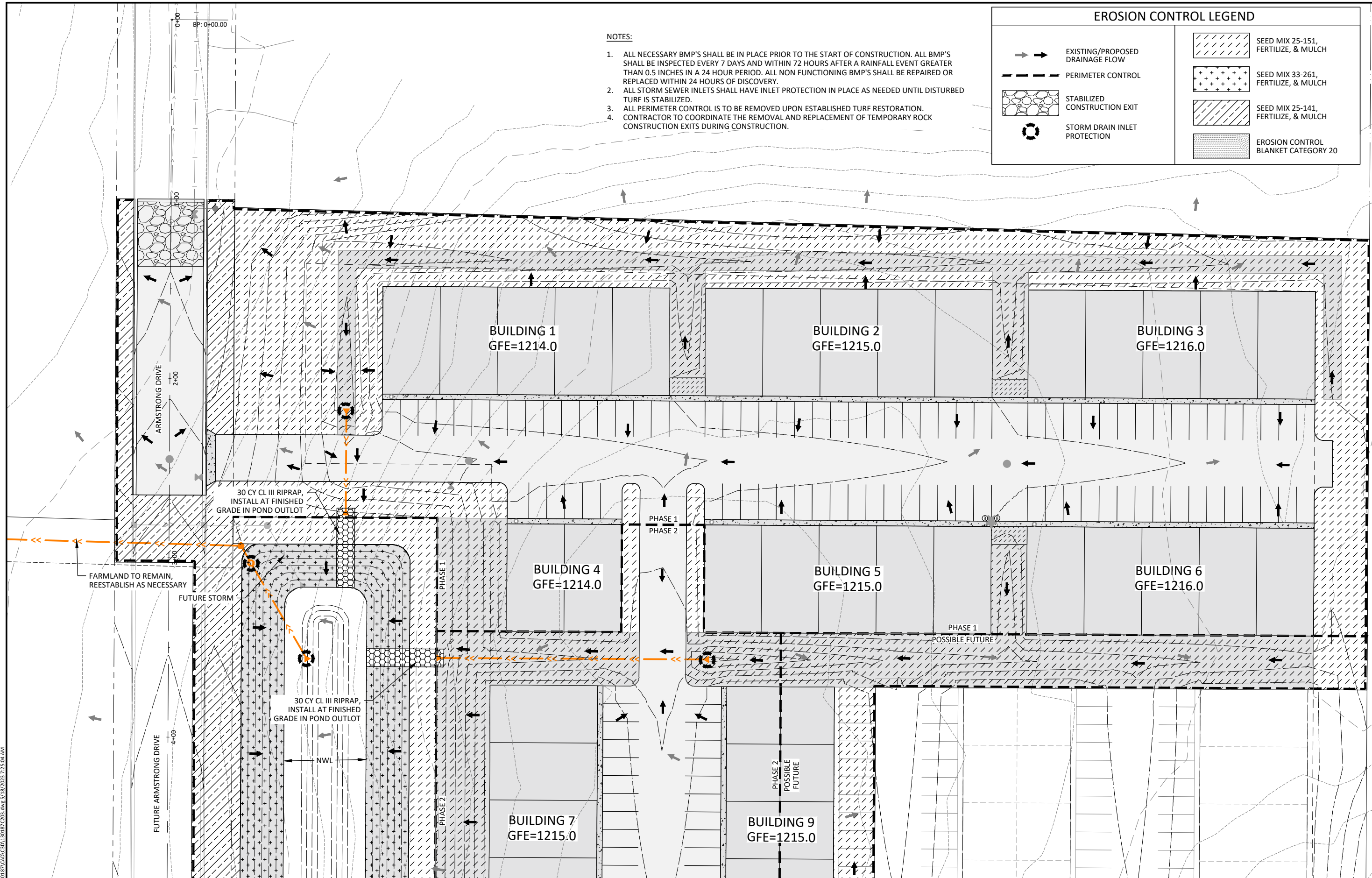

© Bolton & Menk, Inc. 2023. All Rights Reserved. P:\M\130187\CDM\CAD\130187\203.dwg 1/19/2023 7:25:04 AM

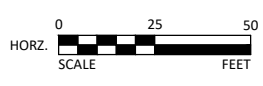

I HEREBY CERTIFY THAT THIS PLAN, SPECIFICATION, OR REPORT WAS PREPARED BY ME OR UNDER MY DIRECT SUPERVISION AND THAT I AM A DULY LICENSED PROFESSIONAL ENGINEER UNDER THE LAWS OF THE STATE OF MINNESOTA.
NOT FOR CONSTRUCTION
 ALEC W. PIETZ, P.E.
 LIC. NO. 59617 DATE XX/XX/XXXX



1960 PREMIER DRIVE
 MANKATO, MINNESOTA 56001
 Phone: (507) 625-4171
 Email: Mankato@bolton-menk.com
 www.bolton-menk.com

DESIGNED	NO.	ISSUED FOR	DATE
AWP			
DRAWN			
AWP			
CHECKED			
MS			
CLIENT PROJ. NO.	0M1.130187		

KEY CITY GROUP, LLC
 FAIRMONT CONTRACTOR CONDOMINIUMS
 STORMWATER POLLUTION PREVENTION PLAN
 EROSION & SEDIMENT CONTROL PLAN

SHEET
C2.07

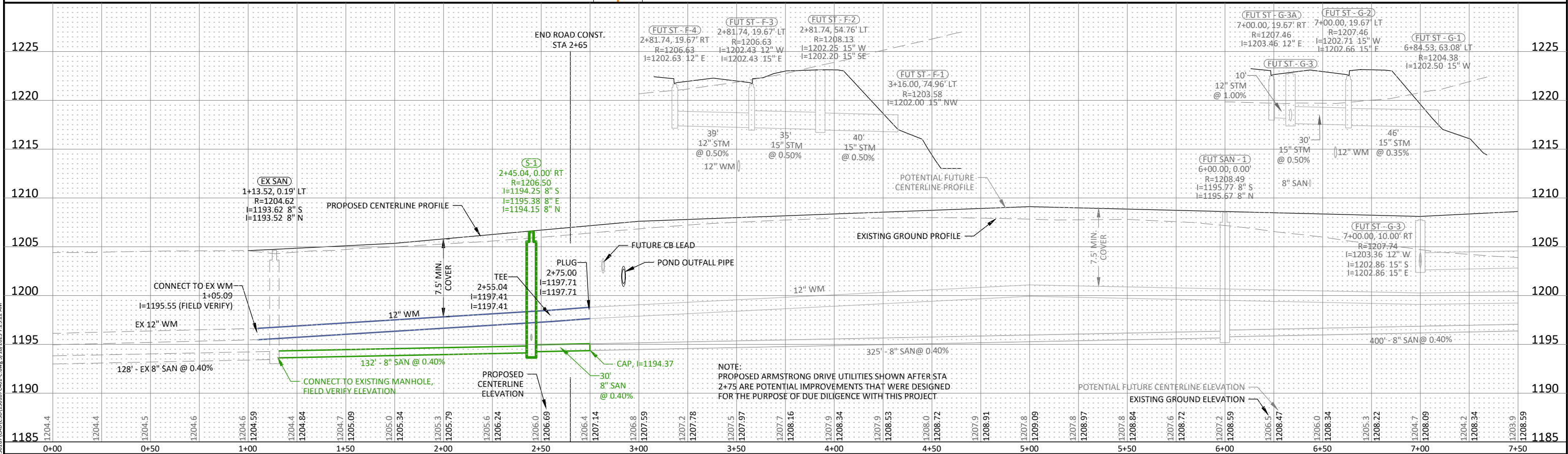
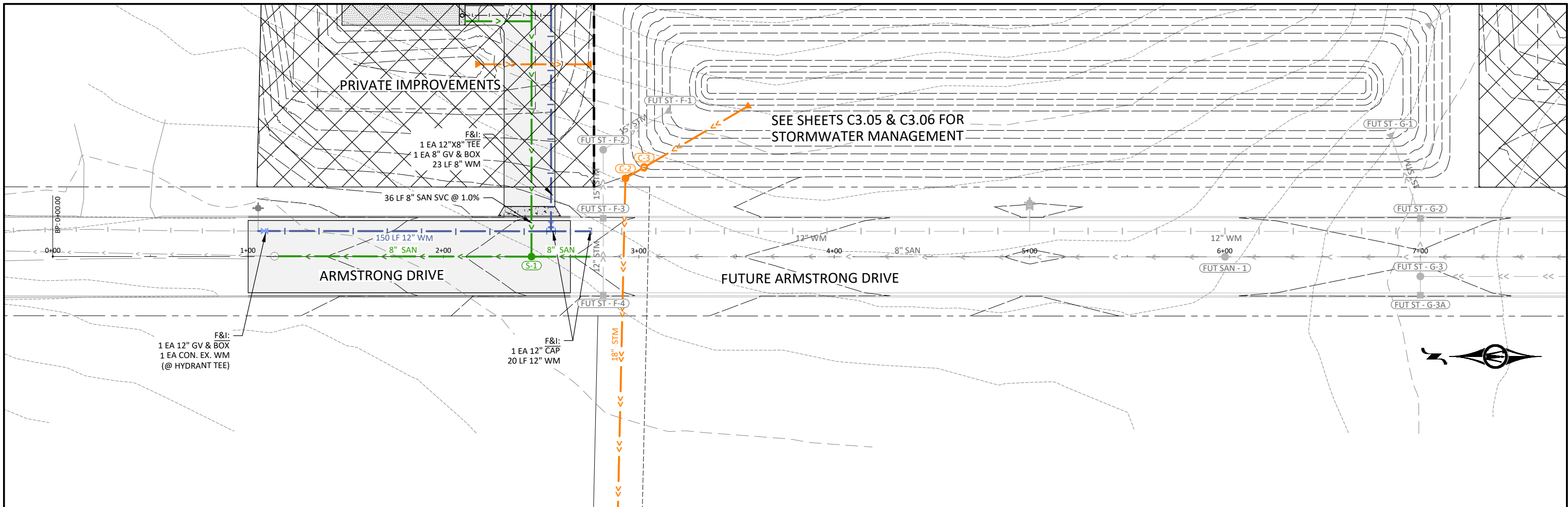

© Bolton & Menk, Inc. 2023. All Rights Reserved.
 PROJECT: FAIRMONT CONTRACTOR CONDOMINIUMS
 DRAWING: C3.01-130187-0403-C.dwg, 5/18/2023 7:25:22 AM

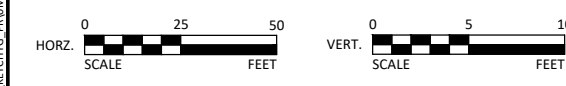

I HEREBY CERTIFY THAT THIS PLAN, SPECIFICATION, OR REPORT WAS PREPARED BY ME OR UNDER MY DIRECT SUPERVISION AND THAT I AM A DULY LICENSED PROFESSIONAL ENGINEER UNDER THE LAWS OF THE STATE OF MINNESOTA.
NOT FOR CONSTRUCTION
 ALEC W. PIETZ, P.E.
 LIC. NO. 59617 DATE XX/XX/XXXX



1960 PREMIER DRIVE
 MANKATO, MINNESOTA 56001
 Phone: (507) 625-4171
 Email: Mankato@bolton-menk.com
 www.bolton-menk.com

DESIGNED	NO.	ISSUED FOR	DATE
AWP			
AWP			
MS			
CLIENT PROJ. NO.	0M1.130187		

KEY CITY GROUP, LLC
 FAIRMONT CONTRACTOR CONDOMINIUMS
 ARMSTRONG DRIVE EXTENSION
 UTILITIES - STA 0+00 TO 7+50

SHEET
C3.01

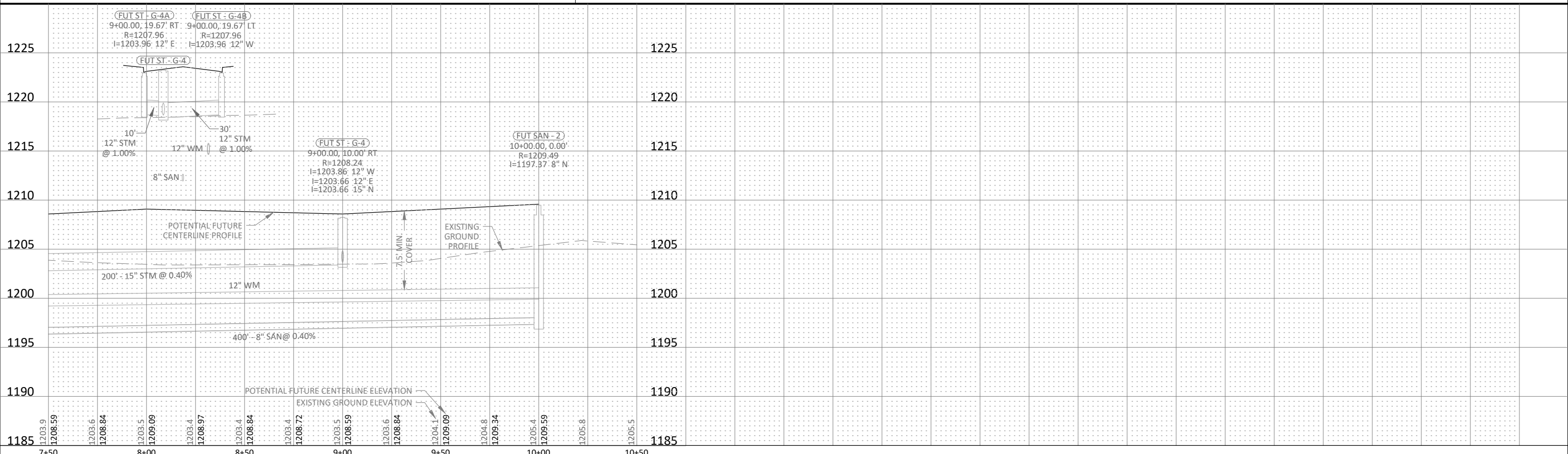
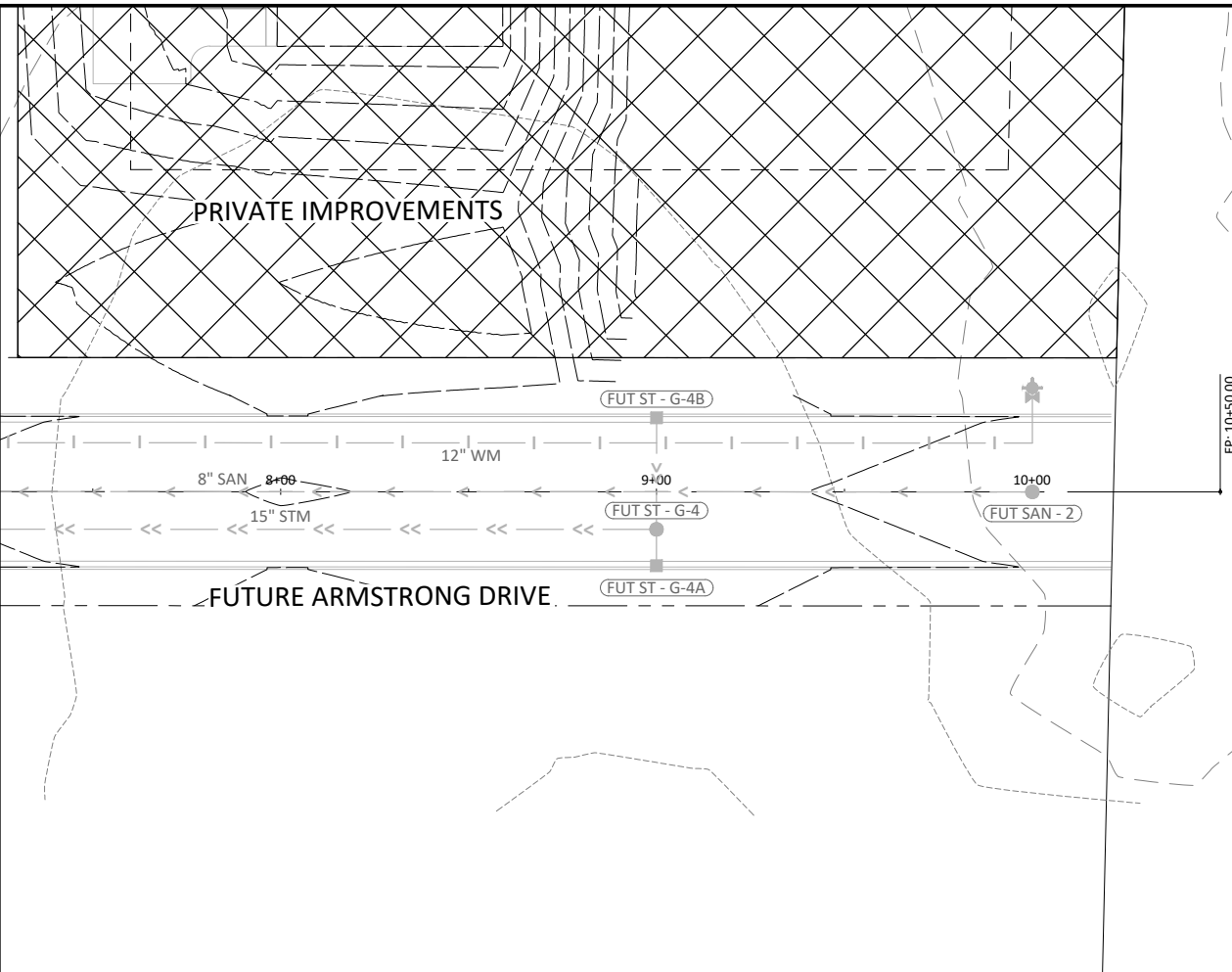

© Bolton & Menk, Inc. 2023. All Rights Reserved. DATE PLOTTED: 10/18/2023 7:23:24 AM

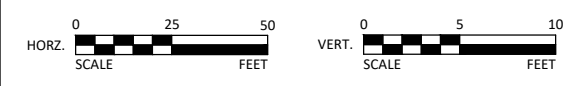

I HEREBY CERTIFY THAT THIS PLAN, SPECIFICATION, OR REPORT WAS PREPARED BY ME OR UNDER MY DIRECT SUPERVISION AND THAT I AM A DULY LICENSED PROFESSIONAL ENGINEER UNDER THE LAWS OF THE STATE OF MINNESOTA.
ALEC W. PIETZ, P.E.
 LIC. NO. 59617 DATE XX/XX/XXXX



1960 PREMIER DRIVE
 MANKATO, MINNESOTA 56001
 Phone: (507) 625-4171
 Email: Mankato@bolton-menk.com
 www.bolton-menk.com

DESIGNED	NO.	ISSUED FOR	DATE
AWP			
DRAWN			
AWP			
CHECKED			
MS			
CLIENT PROJ. NO.	0M1.130187		

KEY CITY GROUP, LLC
 FAIRMONT CONTRACTOR CONDOMINIUMS
 ARMSTRONG DRIVE EXTENSION
 UTILITIES - STA 7+50 TO 10+50

SHEET
C3.02

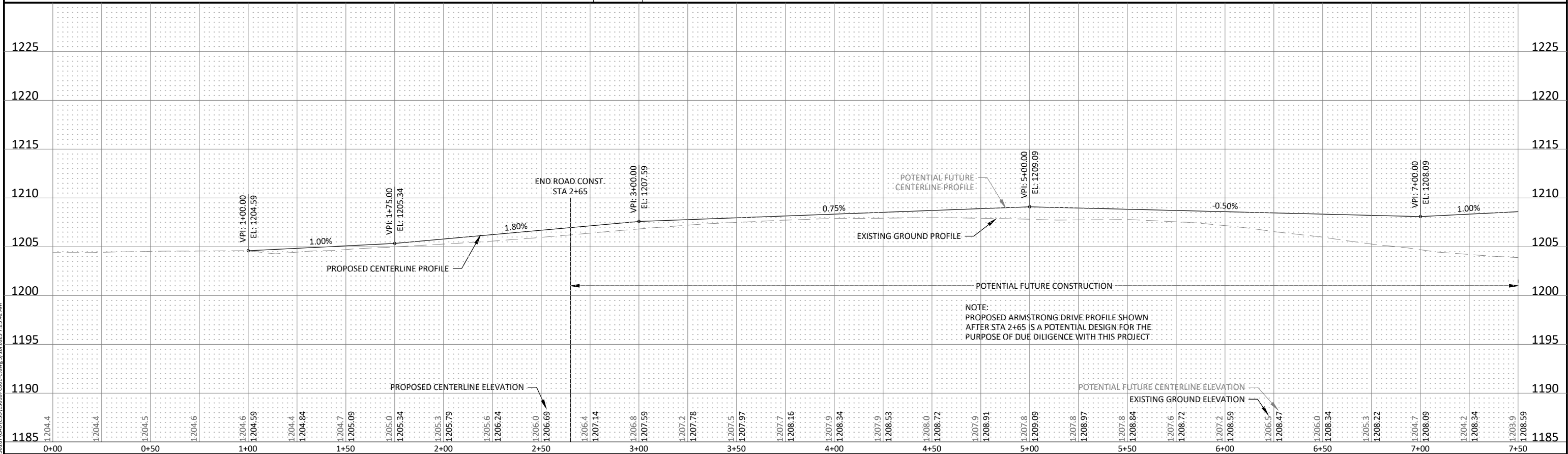
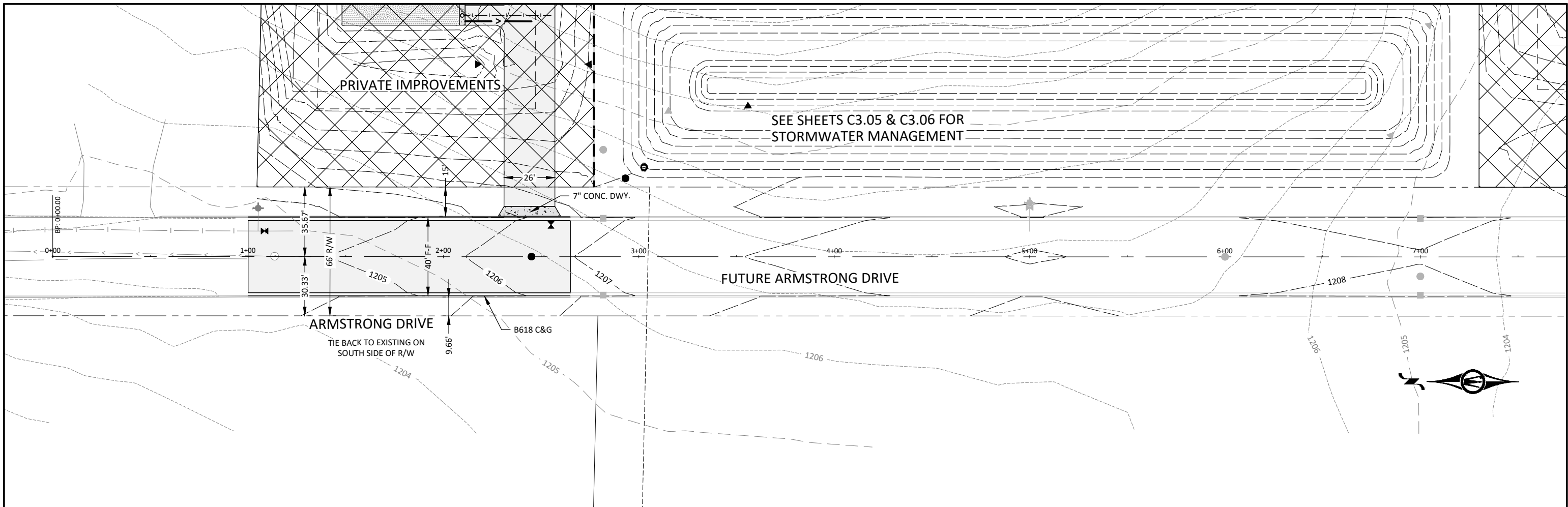

© Bolton & Menk, Inc. 2023. All Rights Reserved. FILE: C:\GIS\Projects\C3.03\DWG\C3.03_01.dwg, 5/18/2023 7:25:42 AM

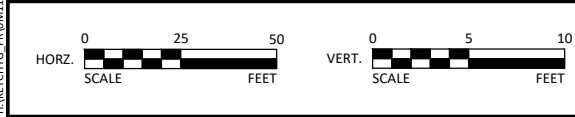

I HEREBY CERTIFY THAT THIS PLAN, SPECIFICATION, OR REPORT WAS PREPARED BY ME OR UNDER MY DIRECT SUPERVISION AND THAT I AM A DULY LICENSED PROFESSIONAL ENGINEER UNDER THE LAWS OF THE STATE OF MINNESOTA.

NOT FOR CONSTRUCTION

ALEC W. PIETZ, P.E.
LIC. NO. 59617 DATE XX/XX/XXXX



1960 PREMIER DRIVE
MANKATO, MINNESOTA 56001
Phone: (507) 625-4171
Email: Mankato@bolton-menk.com
www.bolton-menk.com

DESIGNED	NO.	ISSUED FOR	DATE
AWP			
DRAWN			
AWP			
CHECKED			
MS			
CLIENT PROJ. NO.	0M1.130187		

KEY CITY GROUP, LLC
FAIRMONT CONTRACTOR CONDOMINIUMS
ARMSTRONG DRIVE EXTENSION
STREET - STA 0+00 TO 7+50

SHEET
C3.03

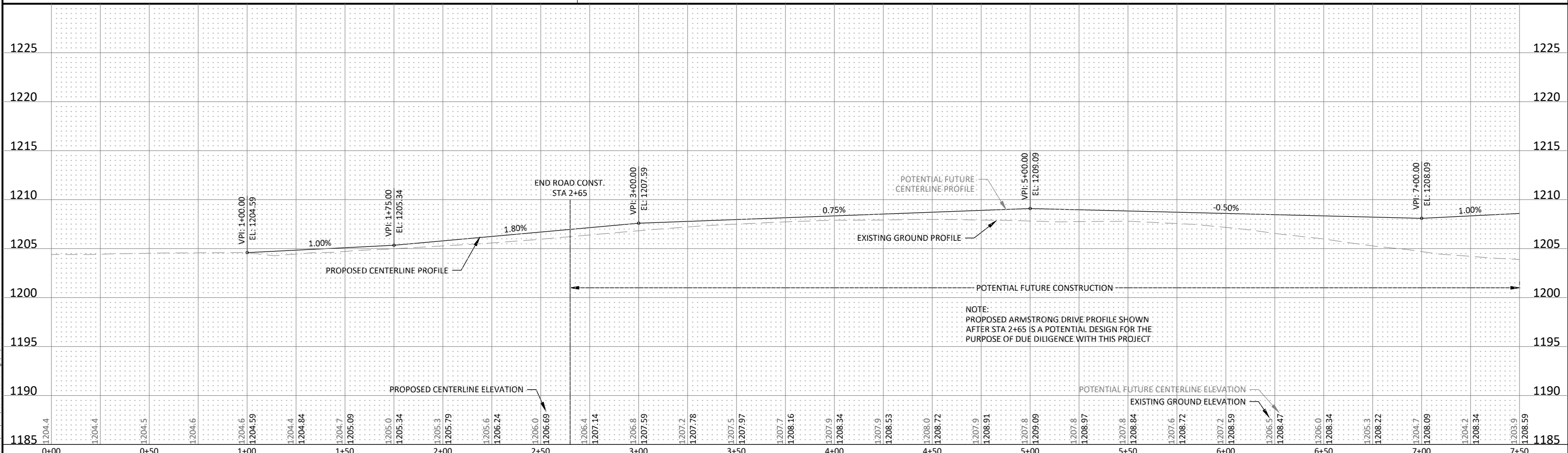
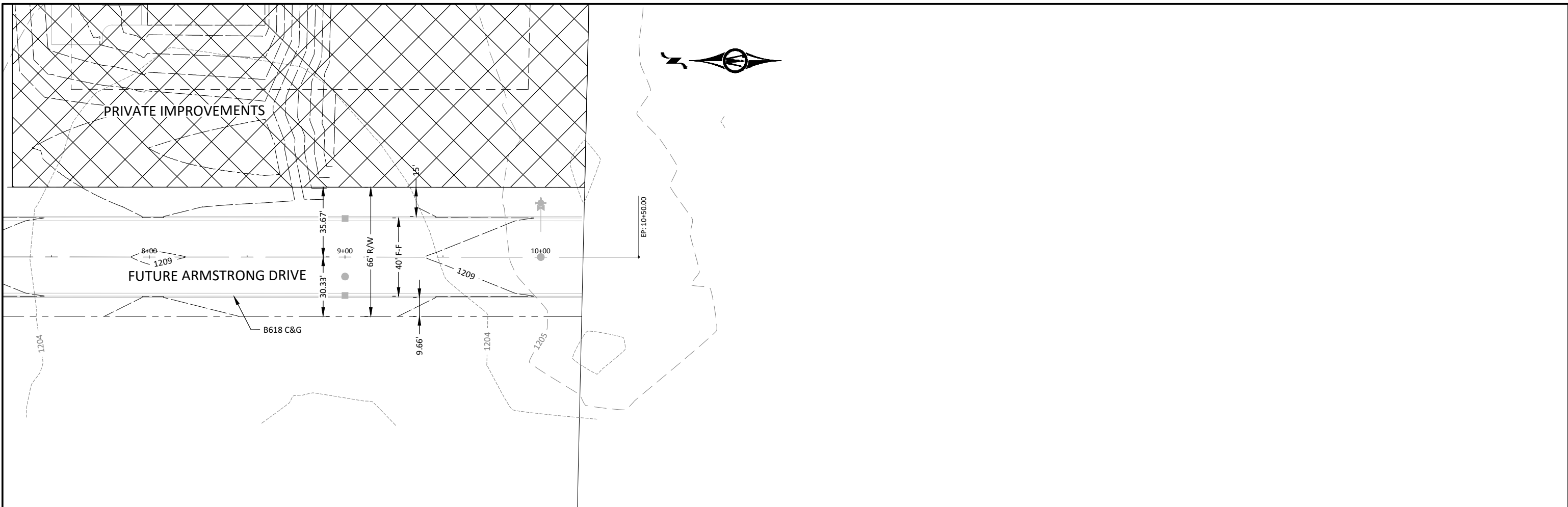

© Bolton & Menk, Inc. 2023. All Rights Reserved. DATE PLOTTED: 01/18/2023 7:25:45 AM

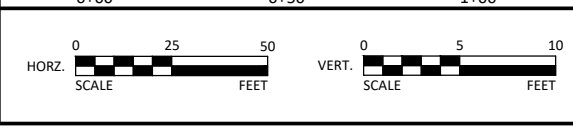

I HEREBY CERTIFY THAT THIS PLAN, SPECIFICATION, OR REPORT WAS PREPARED BY ME OR UNDER MY DIRECT SUPERVISION AND THAT I AM A DULY LICENSED PROFESSIONAL ENGINEER UNDER THE LAWS OF THE STATE OF MINNESOTA.
NOT FOR CONSTRUCTION
 ALEC W. PIETZ, P.E.
 LIC. NO. 59617 DATE XX/XX/XXXX



1960 PREMIER DRIVE
 MANKATO, MINNESOTA 56001
 Phone: (507) 625-4171
 Email: Mankato@bolton-menk.com
 www.bolton-menk.com

DESIGNED	NO.	ISSUED FOR	DATE
AWP			
DRAWN			
AWP			
CHECKED			
MS			
CLIENT PROJ. NO.	0M1.130187		

KEY CITY GROUP, LLC
 FAIRMONT CONTRACTOR CONDOMINIUMS
 ARMSTRONG DRIVE EXTENSION
 STREET - STA 7+50 TO 10+50

SHEET
C3.04

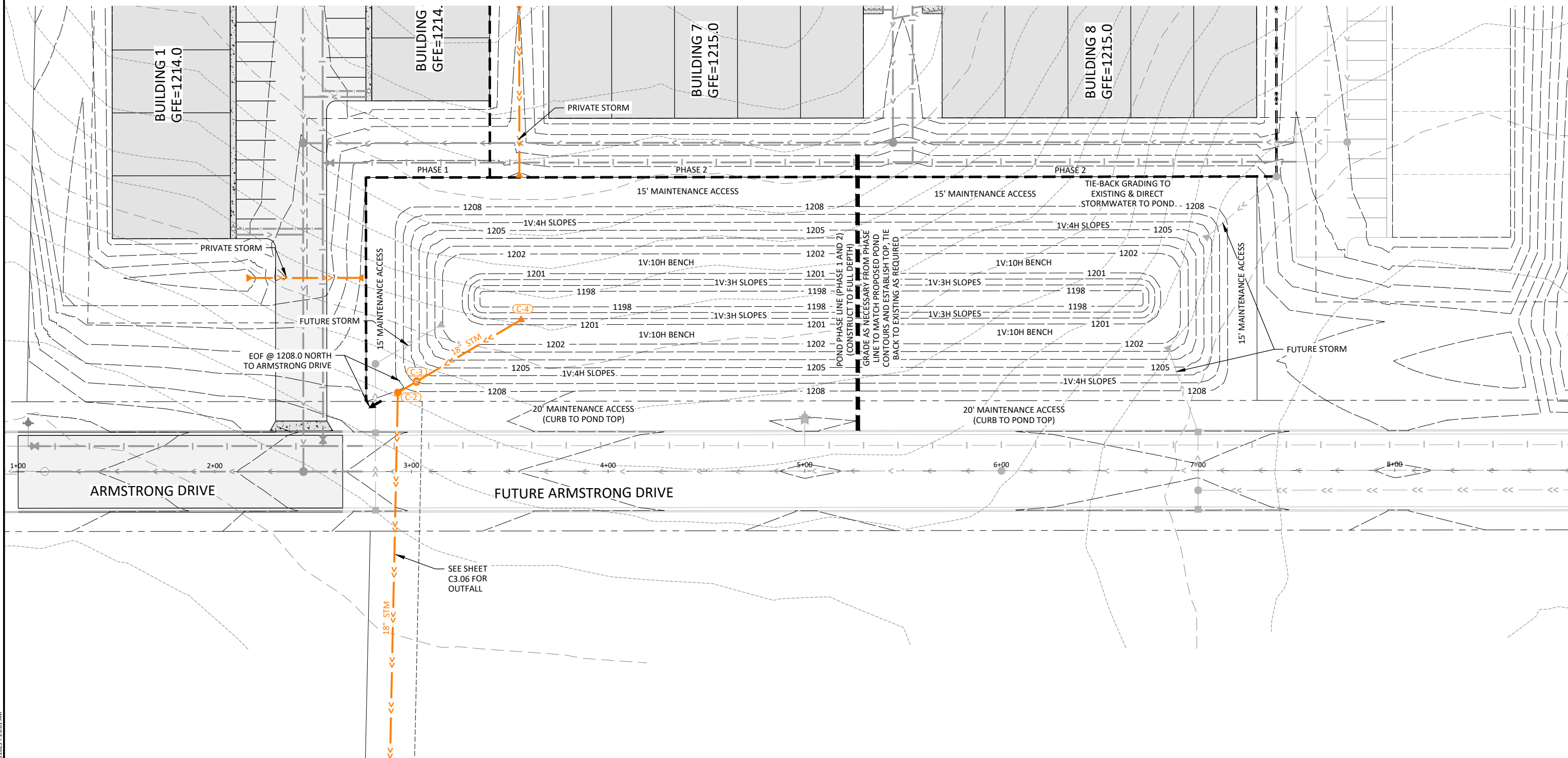

© Bolton & Menk, Inc. 2023. All Rights Reserved. A:\MKTG\C115_P\DWG\30287\CAD\C30180187\SD1_C.dwg, 5/18/2023 7:26:01 AM

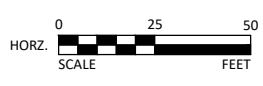

I HEREBY CERTIFY THAT THIS PLAN, SPECIFICATION, OR REPORT WAS PREPARED BY ME OR UNDER MY DIRECT SUPERVISION AND THAT I AM A DULY LICENSED PROFESSIONAL ENGINEER UNDER THE LAWS OF THE STATE OF MINNESOTA.

NOT FOR CONSTRUCTION

ALEC W. PIETZ, P.E.
LIC. NO. 59617 DATE XX/XX/XXXX



1960 PREMIER DRIVE
MANKATO, MINNESOTA 56001
Phone: (507) 625-4171
Email: Mankato@bolton-menk.com
www.bolton-menk.com

DESIGNED	NO.	ISSUED FOR	DATE
AWP			
DRAWN			
AWP			
CHECKED			
MS			
CLIENT PROJ. NO.			
0M1.130187			

KEY CITY GROUP, LLC
FAIRMONT CONTRACTOR CONDOMINIUMS
STORMWATER MANAGEMENT PLAN
POND GRADING AND DETAILS

SHEET
C3.05

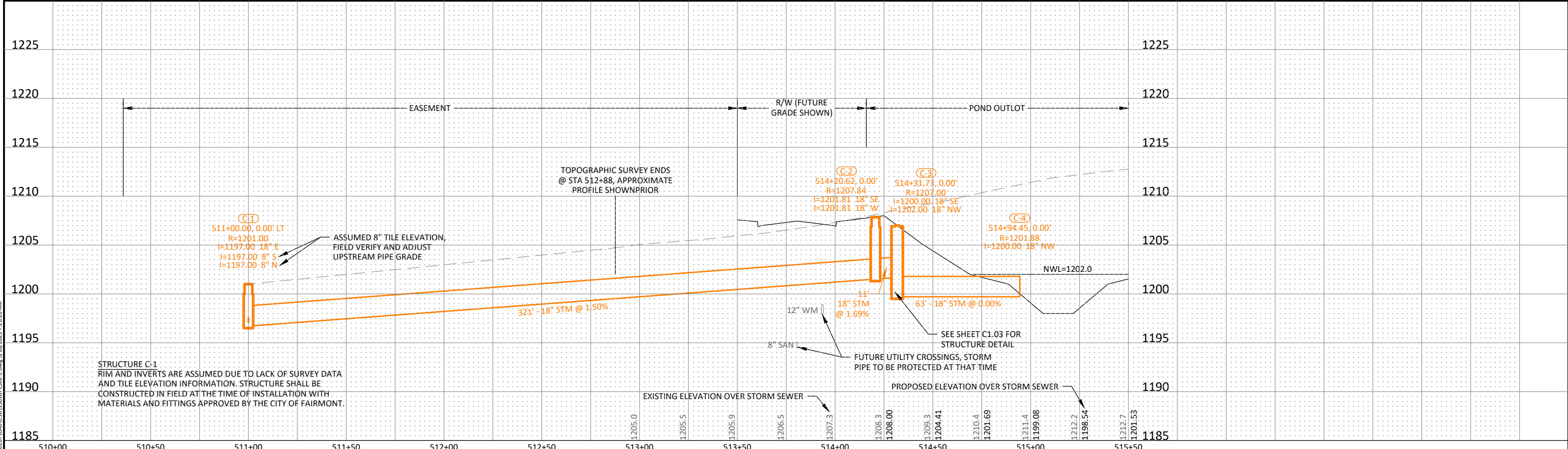
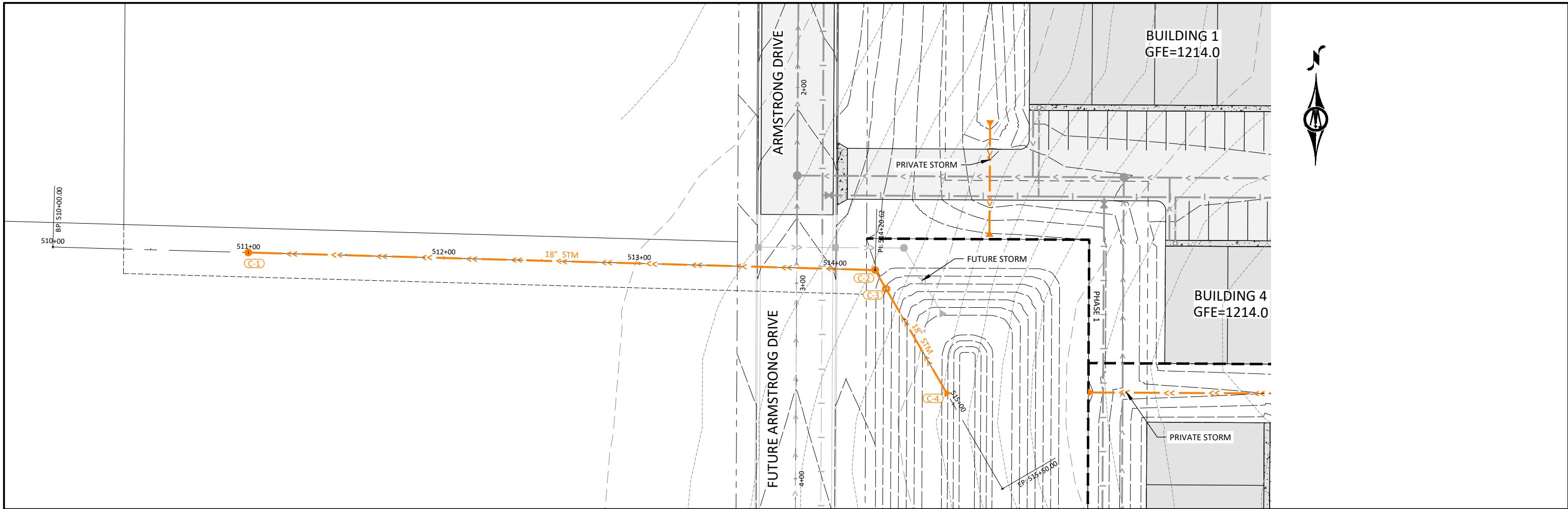

© Bolton & Menk, Inc. 2023. All Rights Reserved. P:\METS\130187\CDM\CAD\130187_C03.dwg: 5/18/2023 7:26:26 AM

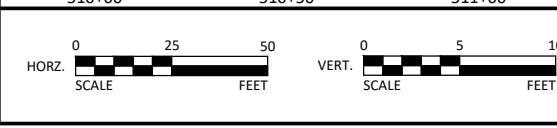

STRUCTURE C-1
 RIM AND INVERTS ARE ASSUMED DUE TO LACK OF SURVEY DATA AND TILE ELEVATION INFORMATION. STRUCTURE SHALL BE CONSTRUCTED IN FIELD AT THE TIME OF INSTALLATION WITH MATERIALS AND FITTINGS APPROVED BY THE CITY OF FAIRMONT.

I HEREBY CERTIFY THAT THIS PLAN, SPECIFICATION, OR REPORT WAS PREPARED BY ME OR UNDER MY DIRECT SUPERVISION AND THAT I AM A DULY LICENSED PROFESSIONAL ENGINEER UNDER THE LAWS OF THE STATE OF MINNESOTA.
NOT FOR CONSTRUCTION
 ALEC W. PIETZ, P.E.
 LIC. NO. 59617 DATE XX/XX/XXXX



1960 PREMIER DRIVE
 MANKATO, MINNESOTA 56001
 Phone: (507) 625-4171
 Email: Mankato@bolton-menk.com
 www.bolton-menk.com

DESIGNED	NO.	ISSUED FOR	DATE
AWP			
DRAWN	AWP		
CHECKED	MS		
CLIENT PROJ. NO.	0M1.130187		

KEY CITY GROUP, LLC
 FAIRMONT CONTRACTOR CONDOMINIUMS
 STORMWATER MANAGEMENT PLAN
 POND OUTFALL

SHEET
C3.06

PHASING NOTE:
 GRADING FOR THE WHOLE SITE INCLUDING PHASES 1 AND 2 ALONG WITH THE POTENTIAL FUTURE LAYOUT IS SHOWN. THE CONTRACTOR SHALL PROVIDE INTERIM GRADING AT THESE PHASE LINES TO PROPERLY DIRECT STORMWATER IN ACCORDANCE WITH THE FINAL GRADING. STORMWATER SHOULD BE DIRECTED TOWARDS THE PROPOSED LOWER AREAS AND ULTIMATELY THE POND ASSOCIATED WITH THIS PROJECT.

LEGEND
 G= GROUND
 B= BITUMINOUS

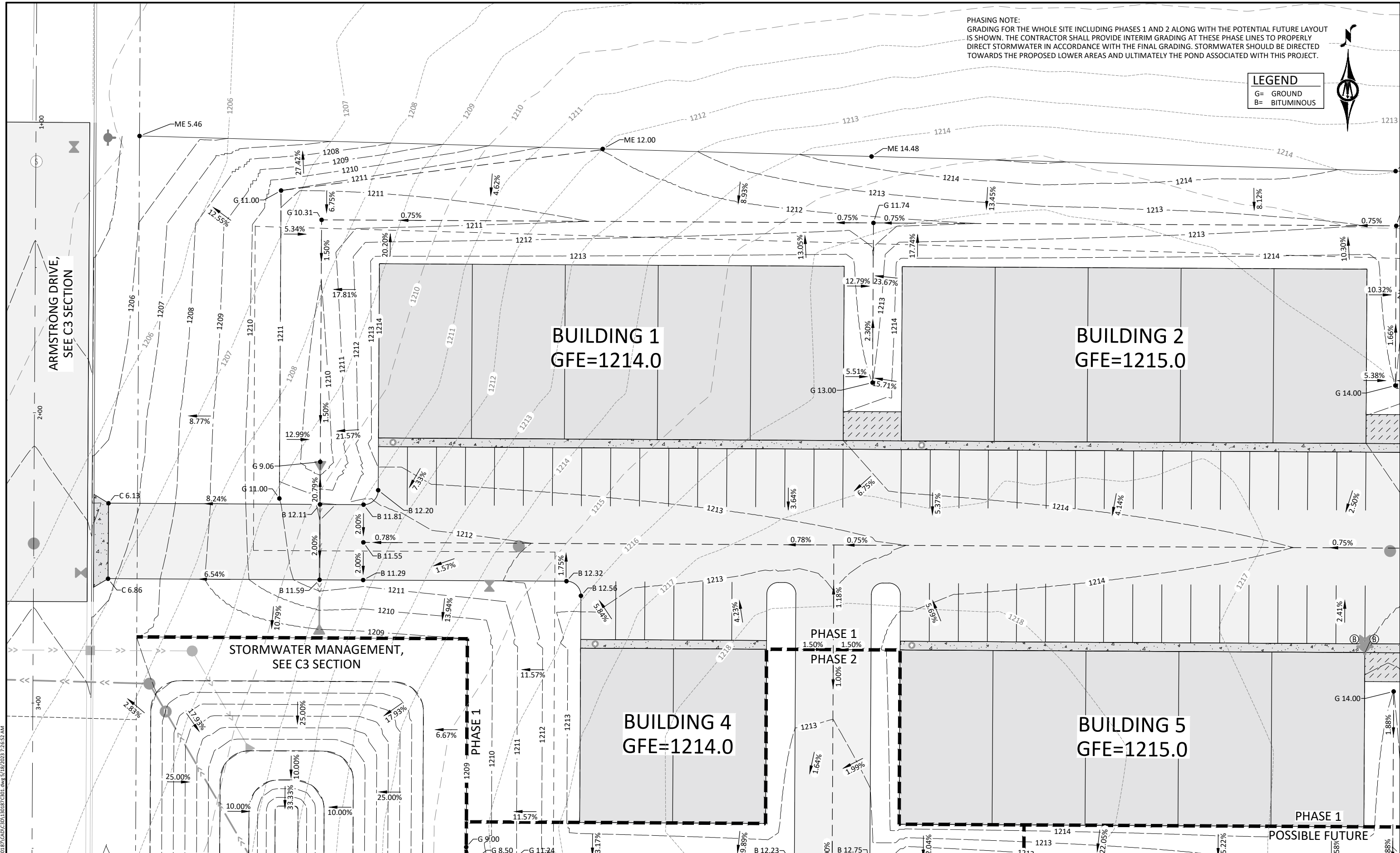

ARMSTRONG DRIVE,
SEE C3 SECTION

STORMWATER MANAGEMENT,
SEE C3 SECTION

BUILDING 1
GFE=1214.0

BUILDING 2
GFE=1215.0

BUILDING 4
GFE=1214.0

BUILDING 5
GFE=1215.0

PHASE 1
1.50% 1.50%

PHASE 2
1.00%

PHASE 1
POSSIBLE FUTURE



NOT FOR CONSTRUCTION
 ALEC W. PIETZ, P.E.
 LIC. NO. 59617 DATE XX/XX/XXXX



1960 PREMIER DRIVE
 MANKATO, MINNESOTA 56001
 Phone: (507) 625-4171
 Email: Mankato@bolton-menk.com
 www.bolton-menk.com

DESIGNED	NO.	ISSUED FOR	DATE
AWP			
AWP			
CHECKED			
MS			
CLIENT PROJ. NO.	0M1.130187		

KEY CITY GROUP, LLC
 FAIRMONT CONTRACTOR CONDOMINIUMS
GRADING PLAN

SHEET
C4.01

© Bolton & Menk, Inc. 2023. All Rights Reserved. PROJECT: FAIRMONT CONTRACTOR CONDOMINIUMS.dwg 1/19/2023 7:26:52 AM

PHASING NOTE:
 GRADING FOR THE WHOLE SITE INCLUDING PHASES 1 AND 2 ALONG WITH THE POTENTIAL FUTURE LAYOUT IS SHOWN. THE CONTRACTOR SHALL PROVIDE INTERIM GRADING AT THESE PHASE LINES TO PROPERLY DIRECT STORMWATER IN ACCORDANCE WITH THE FINAL GRADING. STORMWATER SHOULD BE DIRECTED TOWARDS THE PROPOSED LOWER AREAS AND ULTIMATELY THE POND ASSOCIATED WITH THIS PROJECT.

LEGEND
 G= GROUND
 B= BITUMINOUS

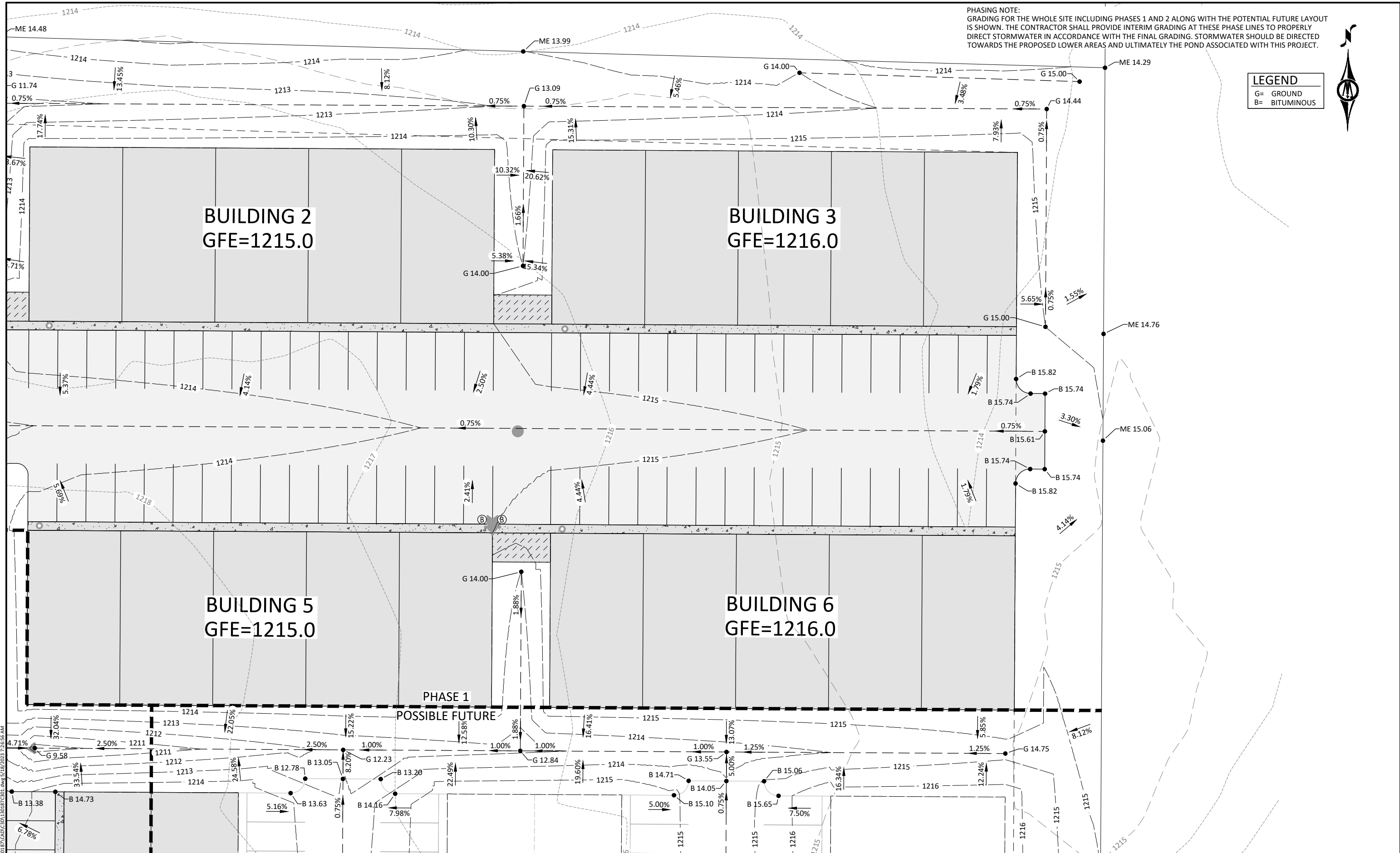

© Bolton & Menk, Inc. 2023. All Rights Reserved.
 A:\PROJECTS_P\1913187\CONDO\1913187_C301.dwg, 15/03/2023 7:26:55 AM

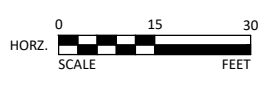

I HEREBY CERTIFY THAT THIS PLAN, SPECIFICATION, OR REPORT WAS PREPARED BY ME OR UNDER MY DIRECT SUPERVISION AND THAT I AM A DULY LICENSED PROFESSIONAL ENGINEER UNDER THE LAWS OF THE STATE OF MINNESOTA.
NOT FOR CONSTRUCTION
 ALEC W. PIETZ, P.E.
 LIC. NO. 59617 DATE XX/XX/XXXX



1960 PREMIER DRIVE
 MANKATO, MINNESOTA 56001
 Phone: (507) 625-4171
 Email: Mankato@bolton-menk.com
 www.bolton-menk.com

DESIGNED	NO.	ISSUED FOR	DATE
AWP			
DRAWN			
AWP			
CHECKED			
MS			
CLIENT PROJ. NO.	0M1.130187		

KEY CITY GROUP, LLC
 FAIRMONT CONTRACTOR CONDOMINIUMS
 GRADING PLAN

SHEET
C4.02

PHASING NOTE:
 GRADING FOR THE WHOLE SITE INCLUDING PHASES 1 AND 2 ALONG WITH THE POTENTIAL FUTURE LAYOUT IS SHOWN. THE CONTRACTOR SHALL PROVIDE INTERIM GRADING AT THESE PHASE LINES TO PROPERLY DIRECT STORMWATER IN ACCORDANCE WITH THE FINAL GRADING. STORMWATER SHOULD BE DIRECTED TOWARDS THE PROPOSED LOWER AREAS AND ULTIMATELY THE POND ASSOCIATED WITH THIS PROJECT.

LEGEND
 G= GROUND
 B= BITUMINOUS

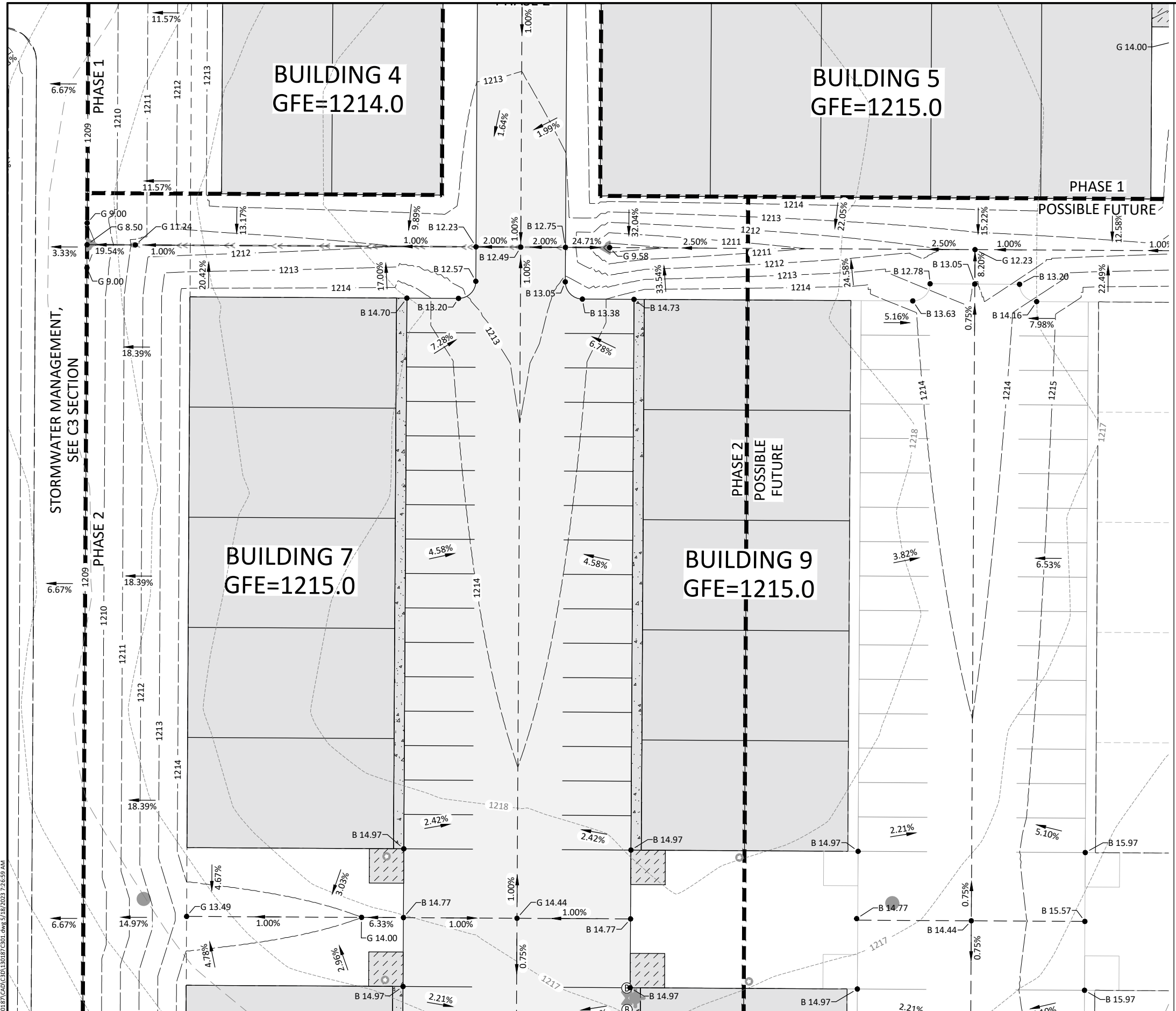

STORMWATER MANAGEMENT,
 SEE C3 SECTION

BUILDING 4
 GFE=1214.0

BUILDING 5
 GFE=1215.0

BUILDING 7
 GFE=1215.0

BUILDING 9
 GFE=1215.0

PHASE 1
 POSSIBLE FUTURE

PHASE 2
 POSSIBLE FUTURE

© Bolton & Menk, Inc. 2023. All Rights Reserved.
 A:\MCT\116_P\116130187\CADD\C3D130187_C3D1.dwg 5/18/2023 7:26:59 AM

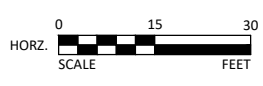

I HEREBY CERTIFY THAT THIS PLAN, SPECIFICATION, OR REPORT WAS PREPARED BY ME OR UNDER MY DIRECT SUPERVISION AND THAT I AM A DULY LICENSED PROFESSIONAL ENGINEER UNDER THE LAWS OF THE STATE OF MINNESOTA.
NOT FOR CONSTRUCTION
 ALEC W. PIETZ, P.E.
 LIC. NO. 59617 DATE XX/XX/XXXX



1960 PREMIER DRIVE
 MANKATO, MINNESOTA 56001
 Phone: (507) 625-4171
 Email: Mankato@bolton-menk.com
 www.bolton-menk.com

DESIGNED	NO.	ISSUED FOR	DATE
AWP			
DRAWN			
AWP			
CHECKED			
MS			
CLIENT PROJ. NO.	0M1-130187		

KEY CITY GROUP, LLC
 FAIRMONT CONTRACTOR CONDOMINIUMS
 GRADING PLAN

SHEET
C4.03

PHASING NOTE:
GRADING FOR THE WHOLE SITE INCLUDING PHASES 1 AND 2 ALONG WITH THE POTENTIAL FUTURE LAYOUT IS SHOWN. THE CONTRACTOR SHALL PROVIDE INTERIM GRADING AT THESE PHASE LINES TO PROPERLY DIRECT STORMWATER IN ACCORDANCE WITH THE FINAL GRADING. STORMWATER SHOULD BE DIRECTED TOWARDS THE PROPOSED LOWER AREAS AND ULTIMATELY THE POND ASSOCIATED WITH THIS PROJECT.

LEGEND
G= GROUND
B= BITUMINOUS

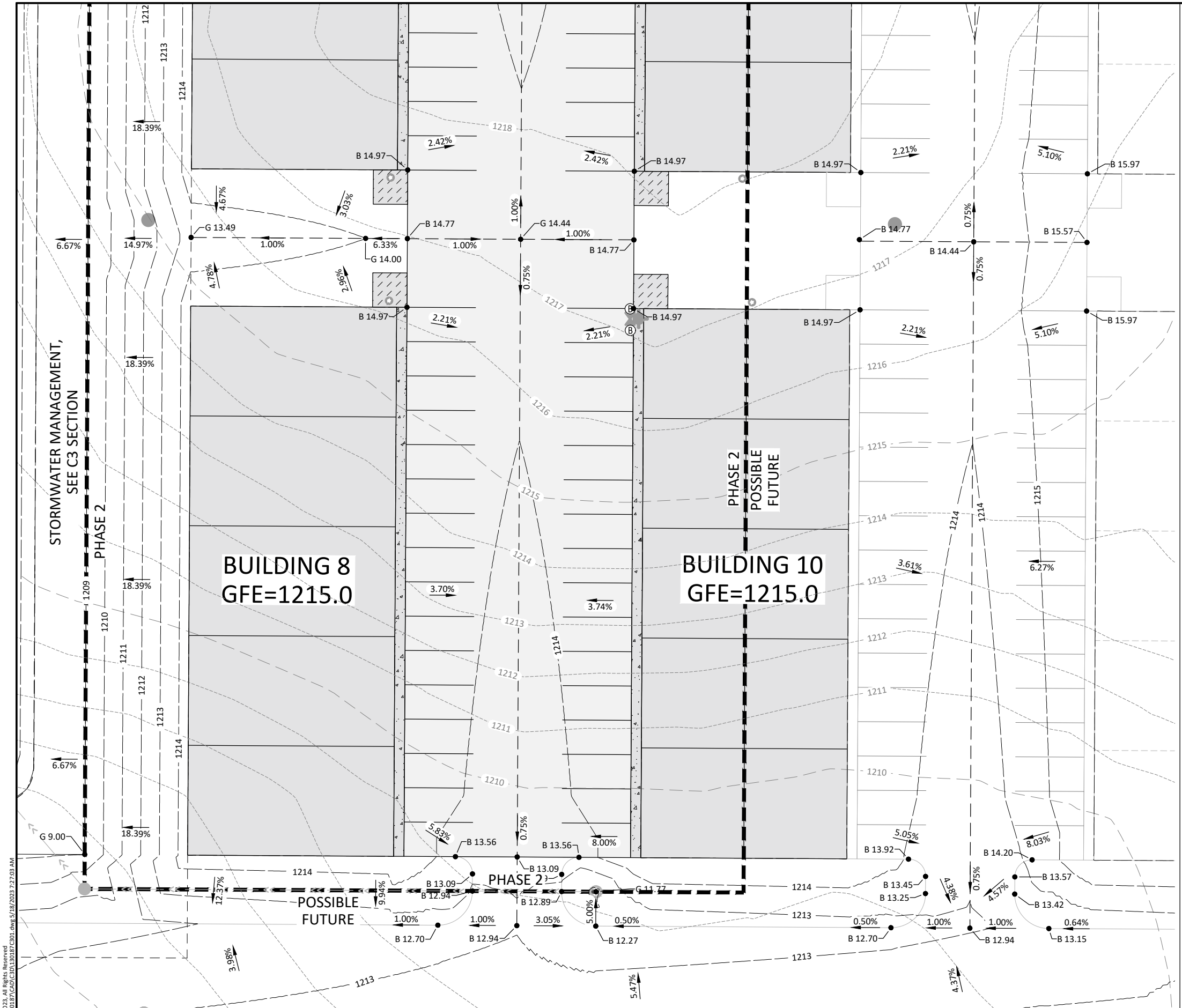

STORMWATER MANAGEMENT,
SEE C3 SECTION
PHASE 2

BUILDING 8
GFE=1215.0

BUILDING 10
GFE=1215.0

PHASE 2
POSSIBLE
FUTURE

PHASE 2
POSSIBLE
FUTURE

© Bolton & Menk, Inc. 2023. All Rights Reserved.
A:\METSITE\PROJECTS\130187\CADD\C3D1\130187_C3D1.dwg 5/15/2023 7:27:05 AM

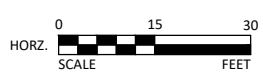

I HEREBY CERTIFY THAT THIS PLAN, SPECIFICATION, OR REPORT WAS PREPARED BY ME OR UNDER MY DIRECT SUPERVISION AND THAT I AM A DULY LICENSED PROFESSIONAL ENGINEER UNDER THE LAWS OF THE STATE OF MINNESOTA.
NOT FOR CONSTRUCTION
ALEX W. PIETZ, P.E.
LIC. NO. 59617 DATE XX/XX/XXXX



1960 PREMIER DRIVE
MANKATO, MINNESOTA 56001
Phone: (507) 625-4171
Email: Mankato@bolton-menk.com
www.bolton-menk.com

DESIGNED	NO.	ISSUED FOR	DATE
AWP			
DRAWN	AWP		
CHECKED	MS		
CLIENT PROJ. NO.	0M1.130187		

KEY CITY GROUP, LLC
FAIRMONT CONTRACTOR CONDOMINIUMS
GRADING PLAN

SHEET
C4.04

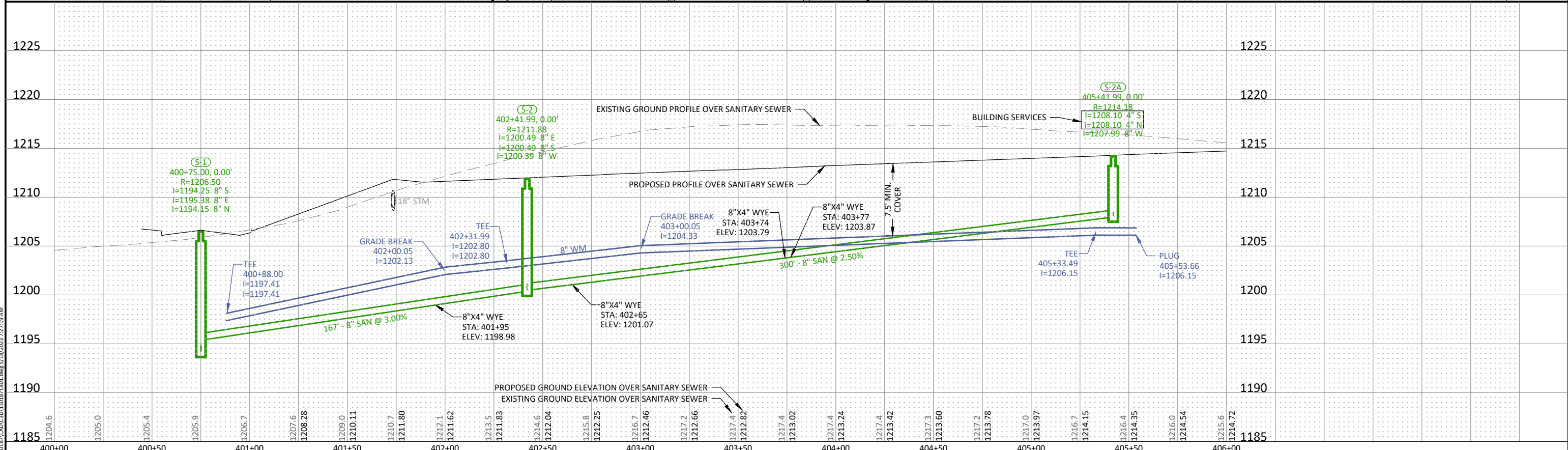
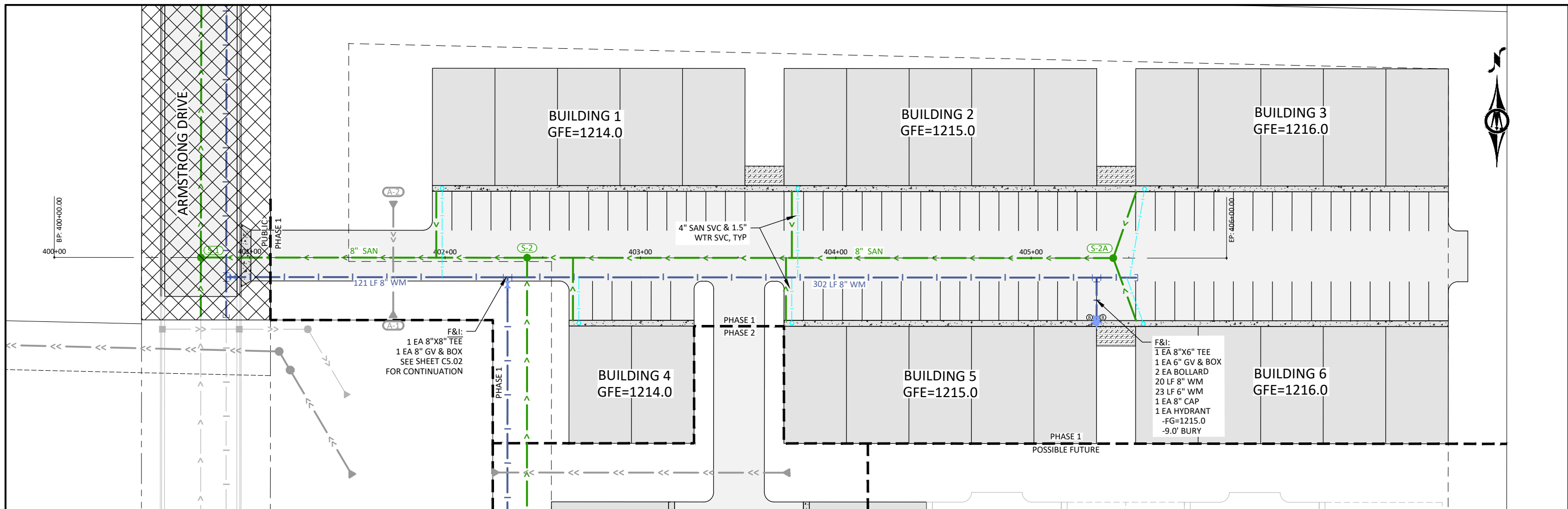

© Bolton & Menk, Inc. 2023. All Rights Reserved. A:\PROJECTS_P\130187\CD\CD\130187_C5.01.dwg 1/18/2023 7:27:19 AM

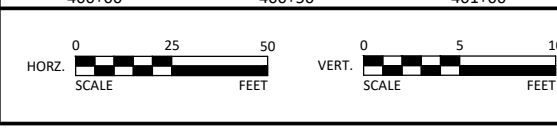

I HEREBY CERTIFY THAT THIS PLAN, SPECIFICATION, OR REPORT WAS PREPARED BY ME OR UNDER MY DIRECT SUPERVISION AND THAT I AM A DULY LICENSED PROFESSIONAL ENGINEER UNDER THE LAWS OF THE STATE OF MINNESOTA.
NOT FOR CONSTRUCTION
 ALEC W. PIETZ P.E.
 LIC. NO. 59617 DATE XX/XX/XXXX



1960 PREMIER DRIVE
 MANKATO, MINNESOTA 56001
 Phone: (507) 625-4171
 Email: Mankato@bolton-menk.com
 www.bolton-menk.com

DESIGNED	NO.	ISSUED FOR	DATE
AWP			
DRAWN			
AWP			
CHECKED			
MS			
CLIENT PROJ. NO.	0M1.130187		

KEY CITY GROUP, LLC
 FAIRMONT CONTRACTOR CONDOMINIUMS
 SANITARY & WATER SERVICE PLAN
 BUILDINGS 1 TO 6 - STA 400+00 TO 406+00

SHEET
C5.01

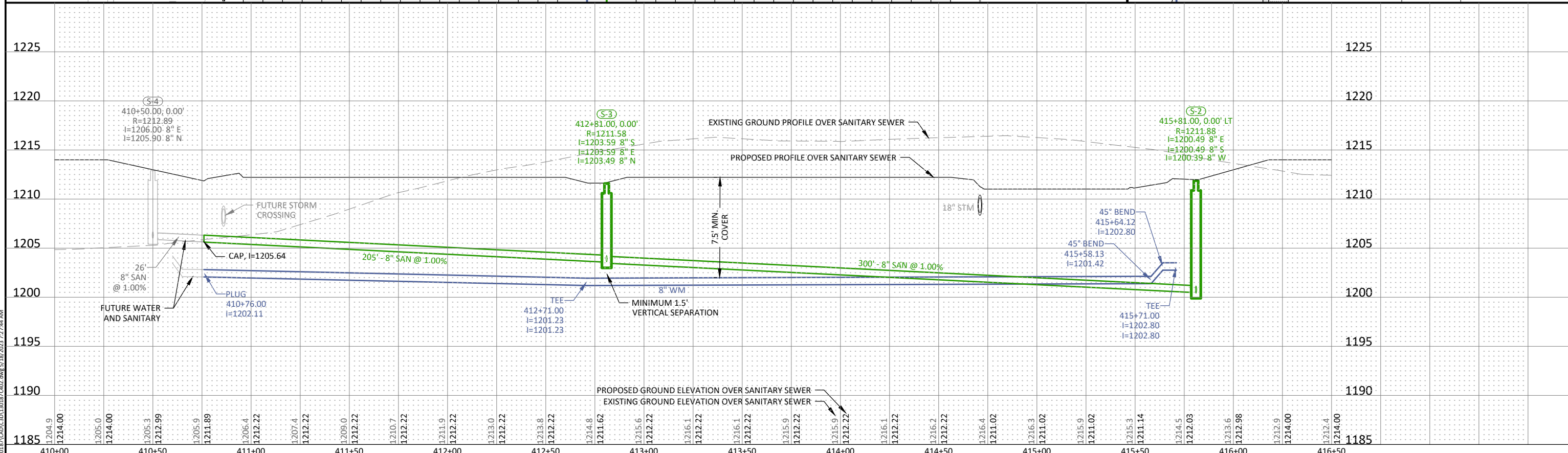
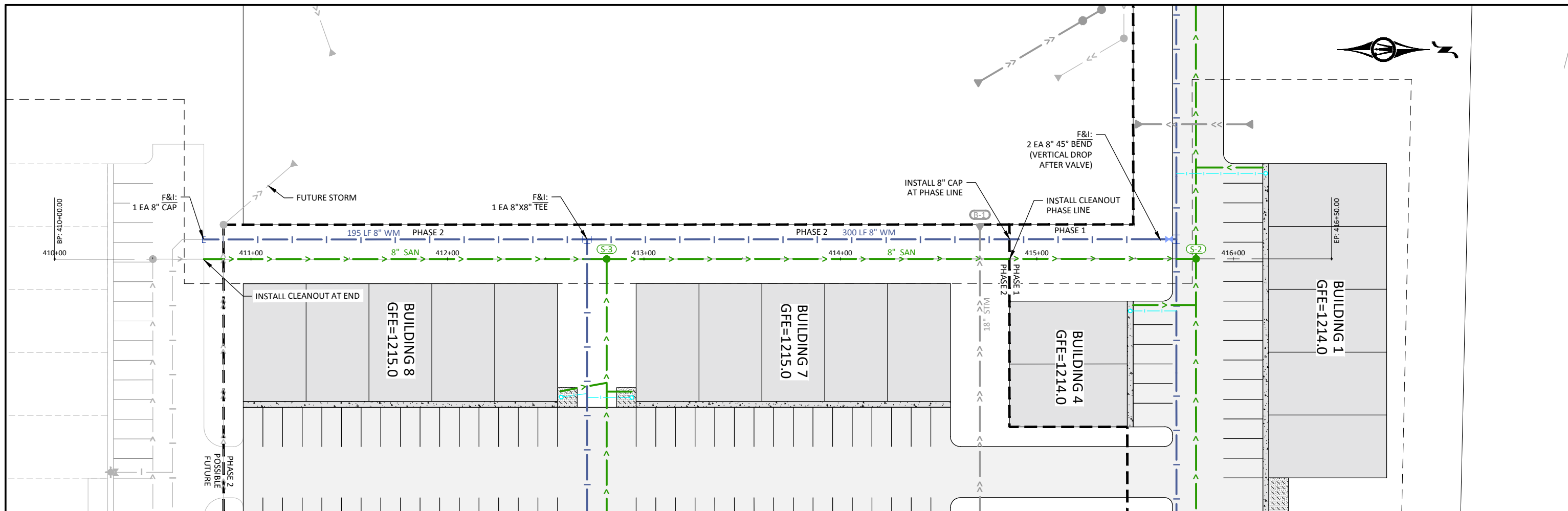

© Bolton & Menk, Inc. 2023. All Rights Reserved. P:\METS\130187\130187.dwg 1/18/2023 7:27:44 AM

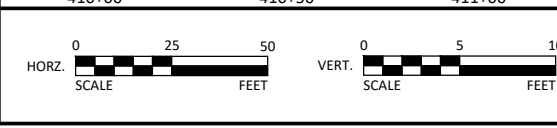

NOT FOR CONSTRUCTION

ALIC W. PIETZ, P.E.
LIC. NO. 59617 DATE XX/XX/XXXX



1960 PREMIER DRIVE
MANKATO, MINNESOTA 56001
Phone: (507) 625-4171
Email: Mankato@bolton-menk.com
www.bolton-menk.com

DESIGNED	NO.	ISSUED FOR	DATE
AWP			
DRAWN			
AWP			
CHECKED			
MS			
CLIENT PROJ. NO.	0M1.130187		

KEY CITY GROUP, LLC
FAIRMONT CONTRACTOR CONDOMINIUMS
SANITARY & WATER SERVICE PLAN
LATERAL - STA 410+00 TO 416+50

SHEET
C5.02

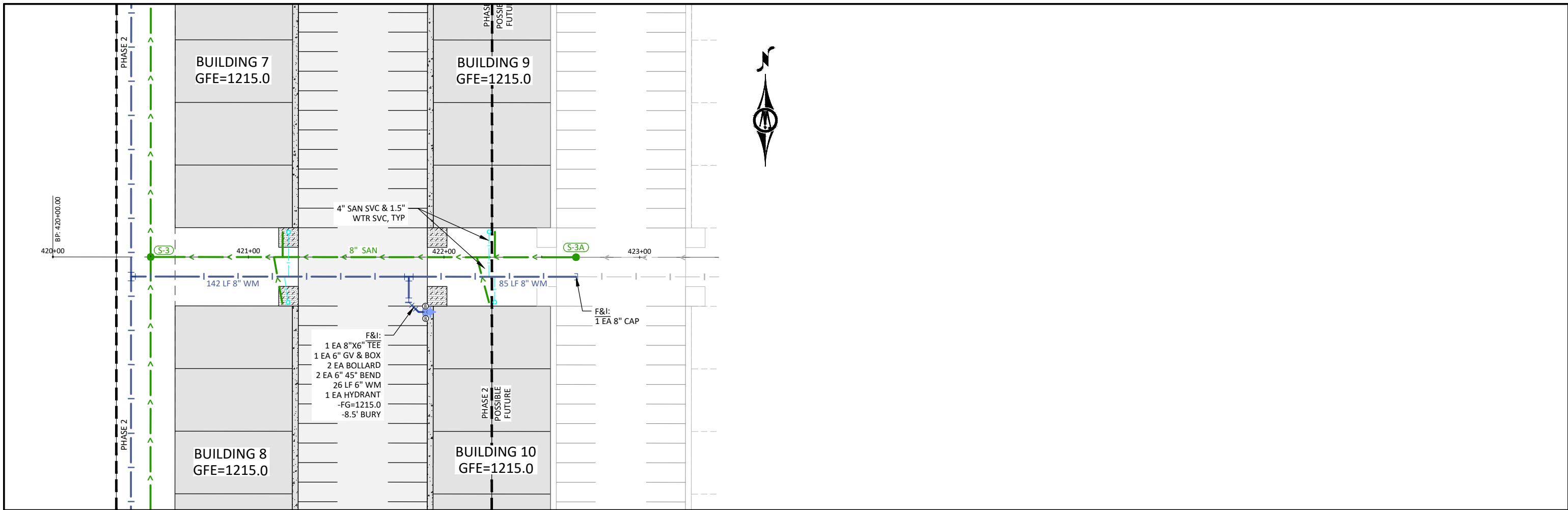

© Bolton & Menk, Inc. 2023. All Rights Reserved. P:\METS\130125_P\DWG\CADD\CADD130125_0401.dwg 15/03/2023 7:28:05 AM

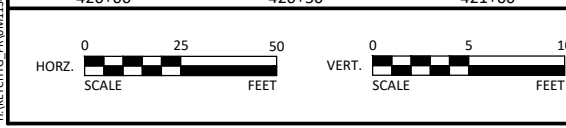

I HEREBY CERTIFY THAT THIS PLAN, SPECIFICATION, OR REPORT WAS PREPARED BY ME OR UNDER MY DIRECT SUPERVISION AND THAT I AM A DULY LICENSED PROFESSIONAL ENGINEER UNDER THE LAWS OF THE STATE OF MINNESOTA.
NOT FOR CONSTRUCTION
 ALEC W. PIETZ, P.E.
 LIC. NO. 59617 DATE XX/XX/XXXX



1960 PREMIER DRIVE
 MANKATO, MINNESOTA 56001
 Phone: (507) 625-4171
 Email: Mankato@bolton-menk.com
 www.bolton-menk.com

DESIGNED	NO.	ISSUED FOR	DATE
AWP			
DRAWN			
CHECKED			
MS			
CLIENT PROJ. NO.	0M1.130187		

KEY CITY GROUP, LLC
 FAIRMONT CONTRACTOR CONDOMINIUMS
 SANITARY & WATER SERVICE PLAN
 BUILDINGS 7 TO 10 - STA 420+00 TO 423+00

SHEET
C5.03

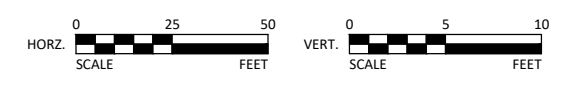
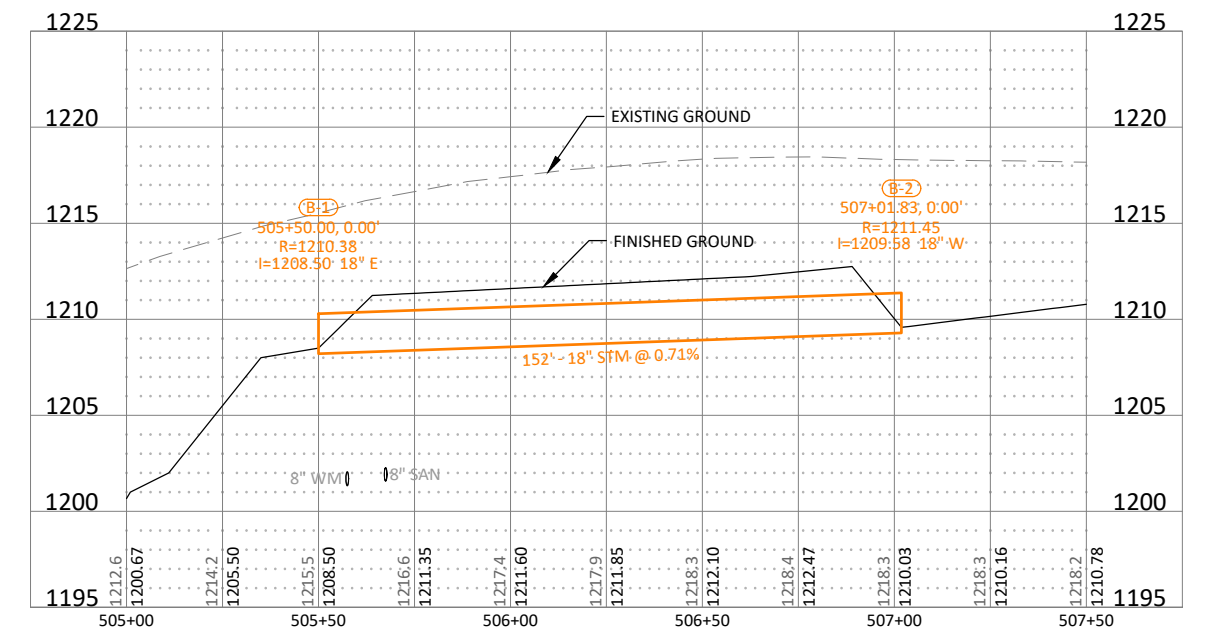
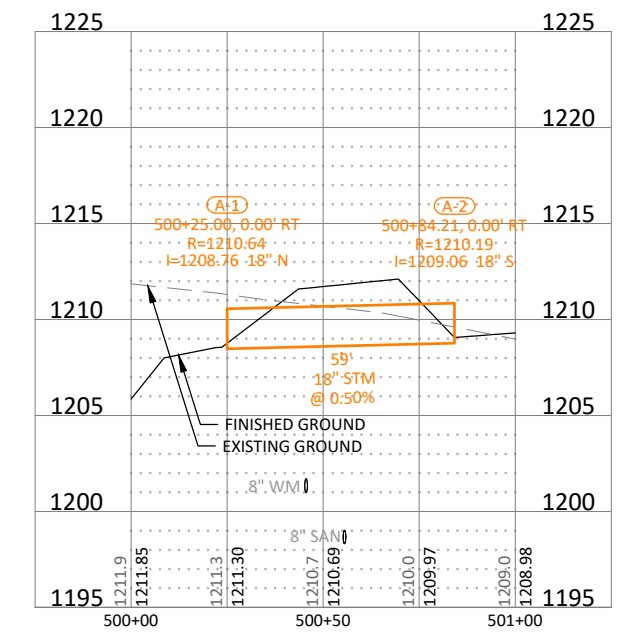
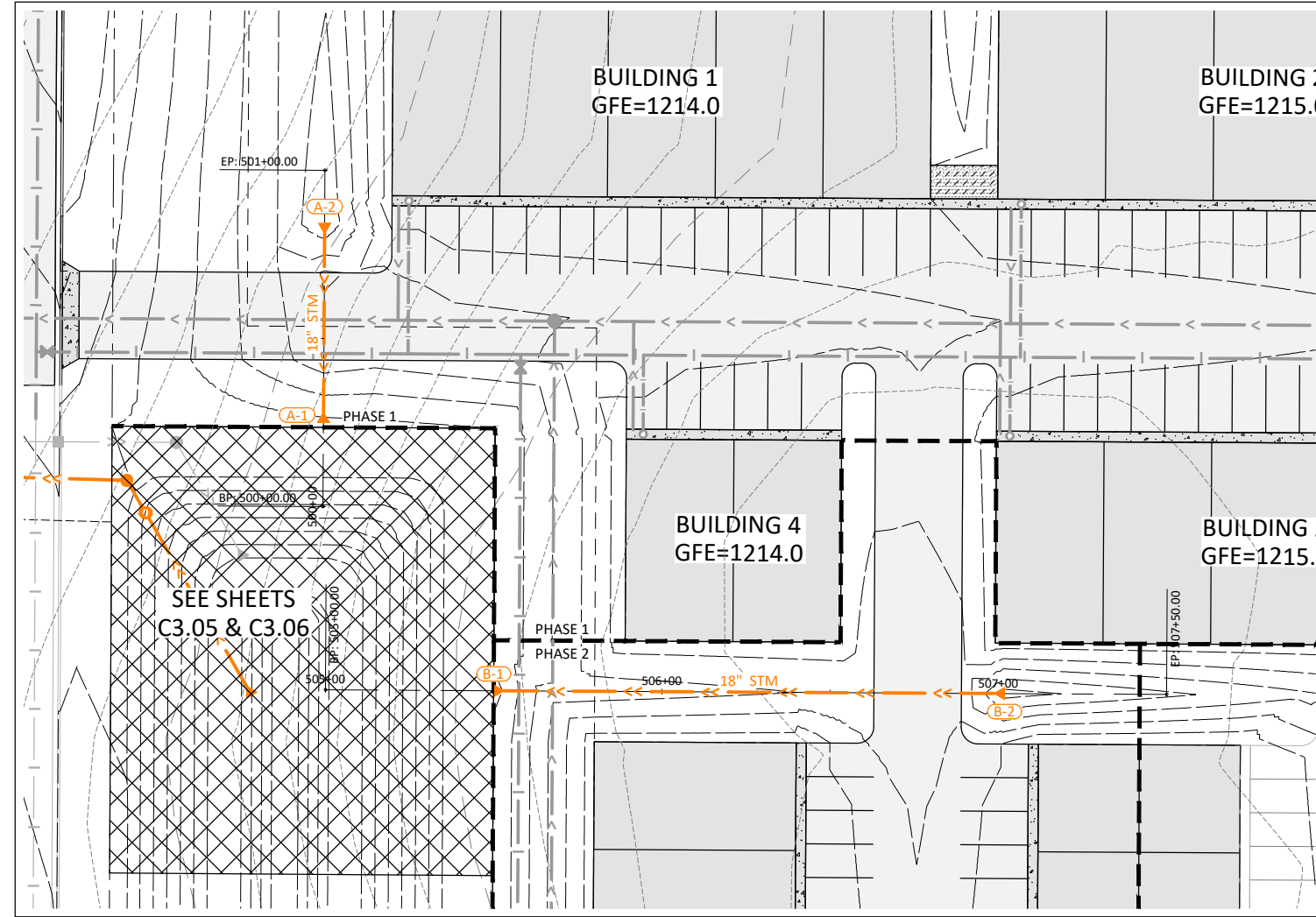
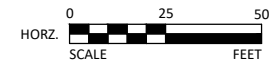

I HEREBY CERTIFY THAT THIS PLAN, SPECIFICATION, OR REPORT WAS PREPARED BY ME OR UNDER MY DIRECT SUPERVISION AND THAT I AM A DULY LICENSED PROFESSIONAL ENGINEER UNDER THE LAWS OF THE STATE OF MINNESOTA.

NOT FOR CONSTRUCTION

ALEC W. PIETZ, P.E.
LIC. NO. 59617 DATE XX/XX/XXXX



1960 PREMIER DRIVE
MANKATO, MINNESOTA 56001
Phone: (507) 625-4171
Email: Mankato@bolton-menk.com
www.bolton-menk.com

DESIGNED	NO.	ISSUED FOR	DATE
AWP			
DRAWN			
AWP			
CHECKED			
MS			
CLIENT PROJ. NO.	0M1.130187		

KEY CITY GROUP, LLC
FAIRMONT CONTRACTOR CONDOMINIUMS
DRAINAGE PLAN

SHEET
C5.04

© Bolton & Menk, Inc. 2023. All Rights Reserved. A:\PROJECTS_P\01\130187\CADD\C301\B01.dwg 5/15/2023 7:28:31 AM

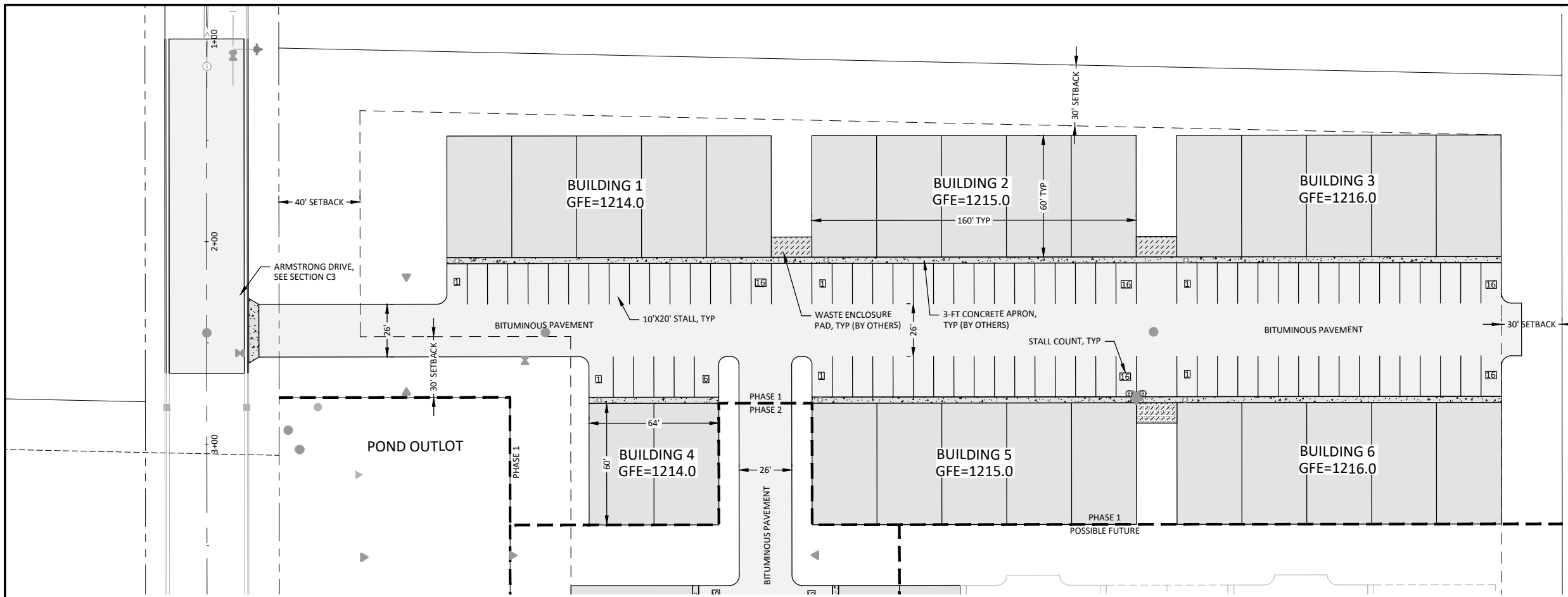

SITE PARKING
 TOTAL STALL COUNT = 150
 # UNITS = 47
 STALL/UNIT = 3.2

LOT COVERAGE
 BUILDINGS 1 TO 10 = 90,240 SF
 LOT AREA = 12.15 AC (529,254 SF)
 BUILDING COVERAGE = 17.05%

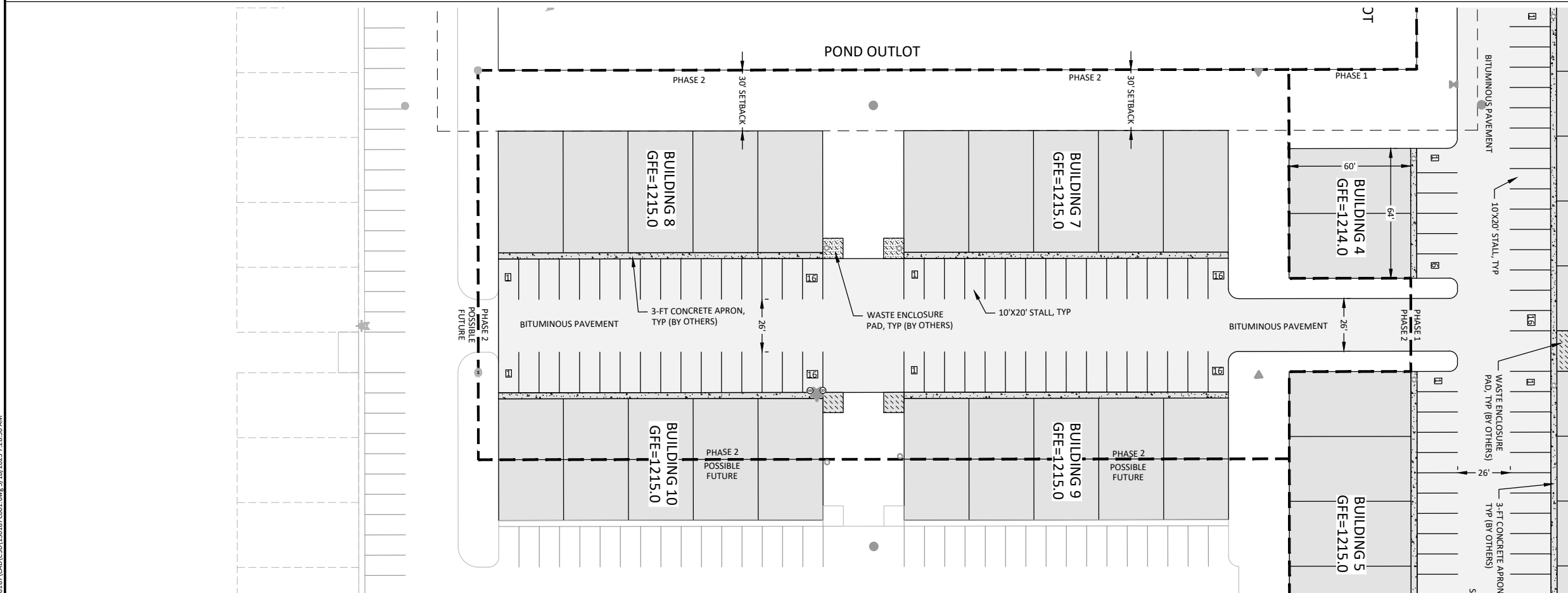

© Bolton & Menk, Inc. 2023. All Rights Reserved. PLM130187.dwg 1/18/2023 7:28:56 AM

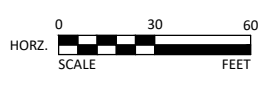

I HEREBY CERTIFY THAT THIS PLAN, SPECIFICATION, OR REPORT WAS PREPARED BY ME OR UNDER MY DIRECT SUPERVISION AND THAT I AM A DULY LICENSED PROFESSIONAL ENGINEER UNDER THE LAWS OF THE STATE OF MINNESOTA.
NOT FOR CONSTRUCTION
 ALEC W. PIETZ, P.E.
 LIC. NO. 59617 DATE XX/XX/XXXX



1960 PREMIER DRIVE
 MANKATO, MINNESOTA 56001
 Phone: (507) 625-4171
 Email: Mankato@bolton-menk.com
 www.bolton-menk.com

DESIGNED	NO.	ISSUED FOR	DATE
AWP			
DRAWN			
CHECKED			
MS			
CLIENT PROJ. NO.	0M1-130187		

KEY CITY GROUP, LLC
 FAIRMONT CONTRACTOR CONDOMINIUMS
 SITE PLAN

SHEET
C6.01



Jon Ahern
Cell Phone: (507) 351-4774
Phone Number: (507) 625-5170
Email: JAhern@clearybuilding.com

4/13/2023
SPRAGUE, DANIEL
Doc ID: 1073520230413102554

Cleary Buildings Project Estimate

Client Proposal - Erected

Project Name: SPRAGUE, DANIEL
Site Address: UNKNOWN FAIRMONT, MINNESOTA 56031
Email: nhillenterprises@gmail.com
Cell Phone: (507) 380-2718

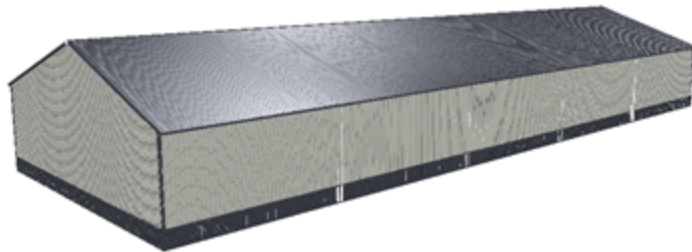
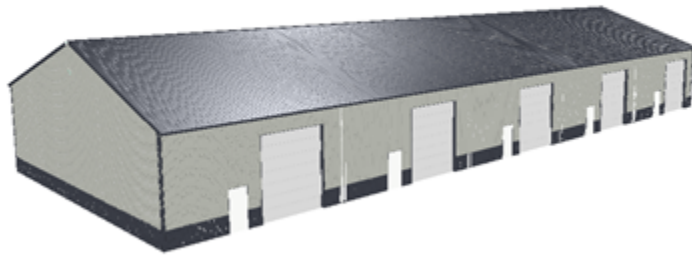

**CITY OF FAIRMONT
PLANNING COMMISSION
RESOLUTION 2023-3**

**RECOMMENDING APPROVAL OF AN INDUSTRIAL PLANNED UNIT DEVELOPMENT AT
LOT 1 BLOCK 1 OF FAIRMONT INDUSTRIAL PARK TWELFTH ADDITION**

Whereas, Midwest Shop Condos, LLC has applied for a planned unit development to develop shop condominiums at Lot 1, Block 1 of the Fairmont Industrial Park Twelfth Addition, and;

Whereas, City staff recommend the request be approved with condition contained in their report, and;

Whereas, the Fairmont Planning Commission held a public hearing on the topic June 6, 2023.

Now therefore, be it resolved by the Fairmont Planning Commission that it makes the following findings of fact:

1. The proposed use meets the vision of the Comprehensive Plan's land use and transportation chapters.
2. The proposed use and intensity of the use are typical for the surrounding area.
3. The proposed Armstrong Drive will extend to the south unimpeded and without any unorderly lot lines or stretches of inefficient right-of-way.
4. The proposal would be served by the proper utilities and the site drainage will be adequately managed per engineering standards.
5. The proposed uses would not be injurious to the surrounding area.
6. The proposal complies with the standards set forth by City Code Section 26-280.

Be it further resolved by the Fairmont Planning Commission that it recommends to Fairmont City Council that the planned unit development be granted with the following conditions:

1. That the development meet the standards set forth by City Code 26-90.
2. That a Development Agreement is entered into by the developer and the City of Fairmont, and is recorded, prior to any construction.
3. That the Fairmont Fire Department provide a statement to City Council with an opinion on if the proposed access and private roadway layout allows for adequate fire service.

Passed and adopted by the Planning Commission of the City of Fairmont on this 6th day of June, 2023.



Tom Mesich, Chair

To the City of Fairmont, City Council;

I have reviewed the site plan for the Key City Group's proposed Fairmont Commercial Condominium development on land currently owned by Fairmont Growth Opportunities at the south end of Armstrong Drive. The plan for this development will include a 125 foot extension of Armstrong Drive to allow entry to the proposed development property. As requested by the Planning Commission, I have looked at the plans and the private roadway layout. I can find no entry or exit problems that would concern the Fairmont Fire Department.

Sincerely,



Bryan Kastning, Fairmont Fire Chief



**Council Member Agenda Request
June 26, 2023**

Agenda Item: 11.1

From: Mayor Baarts and Council Member Miller

Subject: City Administrator, Interim City Administrator Search Update

Staff Action Requested: None

Overview: Mayor Baarts and Council Member Miller will give a bi-weekly update on the City Administrator, Interim City Administrator Search.

Attachments:

Council Action: _____ Date: _____

Accounts Payable
Check Approval List - City Council

From: 05/24/2023

To: 06/27/2023



<u>Vendor</u>	<u>Department</u>	<u>Description</u>	<u>Amount</u>	<u>Check Number</u>	<u>Check Date</u>
<u>A.H. Hermel Company</u>					
A.H. Hermel Company	Aquatic Park	Food for Resale Aquatic Park	2,754.43	160490	06/01/2023 1
A.H. Hermel Company	Aquatic Park	Food for Resale Aquatic Park	-37.46	160859	06/27/2023 1
A.H. Hermel Company	Aquatic Park	Food for Resale Aquatic Park	-19.30	160859	06/27/2023 1
A.H. Hermel Company	Aquatic Park	Food for Resale Aquatic Park	1,511.95	160859	06/27/2023 1
A.H. Hermel Company	Aquatic Park	Food For Resale Aquatic Park	861.16	160812	06/21/2023 1
A.H. Hermel Company	Aquatic Park	Food For Resale Aquatic Park	-37.46	160719	06/15/2023 1
A.H. Hermel Company	Aquatic Park	Food For Resale Aquatic Park	-53.77	160719	06/15/2023 1
A.H. Hermel Company	Aquatic Park	Food For Resale Aquatic Park	15.32	160719	06/15/2023 1
A.H. Hermel Company	Aquatic Park	Food For Resale Aquatic Park	942.21	160719	06/15/2023 1
A.H. Hermel Company	Aquatic Park	Food For Resale Aquatic Park	-56.42	160719	06/15/2023 1
A.H. Hermel Company	Aquatic Park	Food For Resale Aquatic Park	172.92	160620	06/09/2023 1
A.H. Hermel Company	Liquor Store	Supplies Liquor Store	335.09	160604	06/08/2023 1
A.H. Hermel Company	Liquor Store	Supplies Liquor Store	236.85	160604	06/08/2023 1
A.H. Hermel Company	Liquor - Mdse for Resale	Freight	8.95	160604	06/08/2023 1
A.H. Hermel Company	Liquor - Mdse for Resale	Pop/Mix	-50.78	160604	06/08/2023 1
A.H. Hermel Company	Liquor - Mdse for Resale	Misc Merchandise for Resale Liquor Store	80.41	160604	06/08/2023 1
A.H. Hermel Company	Liquor - Mdse for Resale	Freight	8.95	160604	06/08/2023 1
A.H. Hermel Company	Liquor - Mdse for Resale	Misc Merchandise for Resale Liquor Store	41.40	160604	06/08/2023 1
A.H. Hermel Company	Liquor - Mdse for Resale	Pop/Mix	92.57	160604	06/08/2023 1
A.H. Hermel Company	Liquor - Mdse for Resale	Pop/Mix	219.03	160604	06/08/2023 1
A.H. Hermel Company	Liquor - Mdse for Resale	Pop/Mix	-1.92	160604	06/08/2023 1
		Total for A.H. Hermel Company	7,024.13		
<u>A1 Concrete Grinding & Mudjacking</u>					
A1 Concrete Grinding & Mudjacking	Storm Sewer Mnt	Curb & Gutter Christina St 23.6'	1,700.00	160621	06/09/2023 1
A1 Concrete Grinding & Mudjacking	Storm Sewer Mnt	1522 Falcon Dr 38' x 2.6 Curb & Gutter & Pour Around Basin	1,957.00	160621	06/09/2023 1
		Total for A1 Concrete Grinding & Mudjacking	3,657.00		
<u>AdMfg, Inc</u>					
AdMfg, Inc	Economic Development	May 2023 Graphic Design for Rack Cards. Print Rack Cards FAL SMF	835.00	160622	06/09/2023 1
		Total for AdMfg, Inc	835.00		
<u>Advanced Drainage System</u>					
Advanced Drainage System	Storm Sewer Mnt	Couplers & Wall Storm Sewer	212.40	160720	06/15/2023 1
		Total for Advanced Drainage System	212.40		
<u>Aitaro</u>					
Aitaro	Non-departmental	Refund Check 018617-000, 215 E 5th St #2	2.35	160579	06/02/2023 1
Aitaro	Non-departmental	Refund Check 018617-000, 215 E 5th St #2	0.24	160579	06/02/2023 1
Aitaro	Non-departmental	Refund Check 018617-000, 215 E 5th St #2	1.56	160579	06/02/2023 1
Aitaro	Non-departmental	Refund Check 018617-000, 215 E 5th St #2	2.36	160579	06/02/2023 1
		Total for Aitaro	6.51		
<u>Alex Air Apparatus 2 LLC</u>					
Alex Air Apparatus 2 LLC	Fire Fighting	Foam Fire Dept	1,250.00	160860	06/27/2023 1
Alex Air Apparatus 2 LLC	Fire Fighting	Inflatable PFD Automatic W/ Solas Reflective Tape & Whistle	1,639.05	160440	05/26/2023 1

Accounts Payable
Check Approval List - City Council

From: 05/24/2023

To: 06/27/2023



<u>Vendor</u>	<u>Department</u>	<u>Description</u>	<u>Amount</u>	<u>Check Number</u>	<u>Check Date</u>
Alex Air Apparatus 2 LLC	Fire Fighting	Air Leak in sys. Replaced final stage & 2nd stage valves	734.01	160545	06/02/2023 1
		Total for Alex Air Apparatus 2 LLC	3,623.06		
<u>Amazon Capital Services</u>					
Amazon Capital Services	Fire Fighting	Boat Anchor 25lbs Fire Dept	247.23	160721	06/15/2023 1
Amazon Capital Services	City Manager	Office Supplies City Hall	3.40	160721	06/15/2023 1
Amazon Capital Services	Fire Fighting	Lithium Batteries, Alkaline Batteries Fire Dept	68.01	160861	06/27/2023 1
Amazon Capital Services	Fire Fighting	Double A & Triple A Batteries Fire Dept	46.79	160861	06/27/2023 1
Amazon Capital Services	Fire Fighting	Dockline Ropes for Rescue Boat Fire Dept	34.98	160469	05/30/2023 1
Amazon Capital Services	Fire Fighting	All Terrain Chock With Aluminum Cleat, Boat Accessories	343.07	160721	06/15/2023 1
Amazon Capital Services	Fire Fighting	All Terrain Chock W Aluminum Cleat Fire Dept	287.11	160707	06/09/2023 1
Amazon Capital Services	Fire Fighting	Office Supplies City Hall	2.72	160721	06/15/2023 1
Amazon Capital Services	Director of Finance	Office Supplies City Hall	3.40	160721	06/15/2023 1
Amazon Capital Services	Parks	Bug Spray Park Dept	47.98	160721	06/15/2023 1
Amazon Capital Services	Parks	Office Supplies City Hall	2.72	160721	06/15/2023 1
Amazon Capital Services	Parks	Webcam W Microphone	18.99	160546	06/02/2023 1
Amazon Capital Services	Parks	Garden Drill Bit Auger, Fiskars Pruners Park Dept	55.96	160469	05/30/2023 1
Amazon Capital Services	Planning & Zoning	Office Supplies City Hall	3.40	160721	06/15/2023 1
Amazon Capital Services	Police Administration	Office Supplies City Hall	1.36	160721	06/15/2023 1
Amazon Capital Services	Aquatic Park	Hinged Containers Aquatic Park	69.06	160623	06/09/2023 1
Amazon Capital Services	Aquatic Park	Hose Hangout & Storage Cabinet Fire Dept	653.45	160813	06/21/2023 1
Amazon Capital Services	Aquatic Park	Straps for Koala Station Aquatic Park	18.54	160721	06/15/2023 1
Amazon Capital Services	Aquatic Park	Training Aquatic Park	9.99	160546	06/02/2023 1
Amazon Capital Services	Aquatic Park	Sand Toys Aquatic Park	21.99	160546	06/02/2023 1
Amazon Capital Services	Aquatic Park	Staff Jackets Aquatic Park	184.40	160546	06/02/2023 1
Amazon Capital Services	Aquatic Park	Shower Heads Handhelds Aquatic Park	28.78	160721	06/15/2023 1
Amazon Capital Services	Crime Control & Investigation	Office Supplies City Hall	2.04	160721	06/15/2023 1
Amazon Capital Services	Recording & Reporting	Office Supplies City Hall	3.40	160721	06/15/2023 1
Amazon Capital Services	SMEC Building	SMEC Eye Wash Station Refill	31.12	160546	06/02/2023 1
Amazon Capital Services	SMEC Building	SMEC Restroom Repairs	23.99	160721	06/15/2023 1
Amazon Capital Services	Road & Bridge Equipment	5 PK Binders Street Dept	173.24	160469	05/30/2023 1
Amazon Capital Services	Lake Restoration	Office Supplies City Hall	1.36	160721	06/15/2023 1
Amazon Capital Services	Garbage Collection	Rubbermaid Outdoor Storage	683.00	160546	06/02/2023 1
Amazon Capital Services	Economic Development	Office Supplies City Hall	2.04	160721	06/15/2023 1
Amazon Capital Services	Engineering	Screen Protector & Phone Case	27.94	160775	06/15/2023 1
Amazon Capital Services	Engineering	Office Supplies City Hall	7.49	160721	06/15/2023 1
Amazon Capital Services	Engineering	Keyboard for Matt York	39.99	160721	06/15/2023 1
Amazon Capital Services	Paved Streets	Webcam W Microphone	19.00	160546	06/02/2023 1
Amazon Capital Services	Paved Streets	Office Supplies City Hall	1.36	160721	06/15/2023 1
Amazon Capital Services	Building Inspection	Office Supplies City Hall	3.40	160721	06/15/2023 1
Amazon Capital Services	Data Processing	Office Supplies City Hall	2.04	160721	06/15/2023 1
Amazon Capital Services	Liquor Store	Office Supplies City Hall	1.36	160721	06/15/2023 1
Amazon Capital Services	Airport	Office Supplies City Hall	3.40	160721	06/15/2023 1
Amazon Capital Services	Parking Lots	Office Supplies City Hall	1.36	160721	06/15/2023 1

Accounts Payable
Check Approval List - City Council

From: 05/24/2023

To: 06/27/2023



<u>Vendor</u>	<u>Department</u>	<u>Description</u>	<u>Amount</u>	<u>Check Number</u>	<u>Check Date</u>
Total for Amazon Capital Services			3,180.86		
<u>American Engineering Testing, Inc.</u> American Engineering Testing, Inc.	Parks	Gomsrud Park Improvements	7,705.00	160441	05/26/2023 1
Total for American Engineering Testing, Inc.			7,705.00		
<u>American Public Works Association</u> American Public Works Association	Engineering	Membership 06/01/2023 to 05/31/20224 M York	286.25	160722	06/15/2023 1
Total for American Public Works Association			286.25		
<u>American Welding & Gas, Inc.</u> American Welding & Gas, Inc.	Aquatic Park	Weldmat-308L .030 2#SP Wire Aquatic Park	88.57	160491	06/01/2023 1
Total for American Welding & Gas, Inc.			88.57		
<u>Ancom Technical Center</u> Ancom Technical Center	Fire Fighting	Remove dual control head radio from old engine & reinstall in n	898.25	160470	05/30/2023 1
Total for Ancom Technical Center			898.25		
<u>Aramark Uniform Services</u> Aramark Uniform Services	Central Garage	Launder Uniforms for Mechanics	43.68	160442	05/26/2023 1
Aramark Uniform Services	Central Garage	Launder Uniforms for Mechanics	43.68	160471	05/30/2023 1
Aramark Uniform Services	Central Garage	Launder Uniforms for Mechanics	43.68	160547	06/02/2023 1
Aramark Uniform Services	Central Garage	Launder Uniforms for Mechanics	43.68	160708	06/09/2023 1
Aramark Uniform Services	Parks	Cleaning Supplies Park Dept	36.08	160442	05/26/2023 1
Aramark Uniform Services	Parks	Cleaning Supplies Park Dept	36.07	160547	06/02/2023 1
Aramark Uniform Services	Parks	Cleaning Supplies Park Dept	36.07	160471	05/30/2023 1
Aramark Uniform Services	Parks	Cleaning Supplies Park Dept	36.08	160708	06/09/2023 1
Aramark Uniform Services	Paved Streets	Cleaning Supplies Street Dept	36.07	160442	05/26/2023 1
Aramark Uniform Services	Paved Streets	Cleaning Supplies Street Dept	36.08	160547	06/02/2023 1
Aramark Uniform Services	Paved Streets	Cleaning Supplies Street Dept	36.08	160471	05/30/2023 1
Aramark Uniform Services	Paved Streets	Cleaning Supplies Street Dept	36.07	160708	06/09/2023 1
Total for Aramark Uniform Services			463.32		
<u>Arnold Motor Supply</u> Arnold Motor Supply	Parks	Spark Plug Craftsman Tiller Park Dept	2.90	160472	05/30/2023 1
Arnold Motor Supply	Road & Bridge Equipment	Engine Oil Filter	20.93	160492	06/01/2023 1
Total for Arnold Motor Supply			23.83		
<u>Arnold's of No. Mankato</u> Arnold's of No. Mankato	Parks	Hyd Filter Park #534	32.83	160814	06/21/2023 1
Arnold's of No. Mankato	Parks	Shaft Park #534	106.66	160814	06/21/2023 1
Total for Arnold's of No. Mankato			139.49		
<u>Asmus</u> Asmus	Crime Control & Investigation	MPPOA Convention Alexandria MN 06/09 to 06/11/23	779.23	0	06/21/2023 1
Asmus	Crime Control & Investigation	Interview/Interrogation Training Rochester, MN 05/30 to 05/31/23	283.86	0	06/09/2023 1
Total for Asmus			1,063.09		
<u>Atlantic Coca-Cola Bottling Company</u> Atlantic Coca-Cola Bottling Company	Liquor - Mdse for Resale	Pop/Mix	97.00	160605	06/08/2023 1
Atlantic Coca-Cola Bottling Company	Liquor - Mdse for Resale	Pop/Mix	148.08	160605	06/08/2023 1
Total for Atlantic Coca-Cola Bottling Company			245.08		

Accounts Payable
Check Approval List - City Council



From: 05/24/2023

To: 06/27/2023

<u>Vendor</u>	<u>Department</u>	<u>Description</u>	<u>Amount</u>	<u>Check Number</u>	<u>Check Date</u>
<u>Austin, Ben</u>					
Austin, Ben	Paved Streets	Reimbursement for Safety Boots	214.99	160815	06/21/2023 1
		Total for Austin, Ben	214.99		
<u>Barco Municipal Products, Inc.</u>					
Barco Municipal Products, Inc.	Paved Streets	Sign Repair	912.81	160816	06/21/2023 1
		Total for Barco Municipal Products, Inc.	912.81		
<u>Bass</u>					
Bass	Crime Control & Investigation	Safety Eye Wear Reimbursement	118.85	0	06/02/2023 1
Bass	Crime Control & Investigation	MNJOA Conference/Training Duluth, MN 06/11 to 06/17/2023	686.65	0	06/21/2023 1
		Total for Bass	805.50		
<u>Bauer Built Tire</u>					
Bauer Built Tire	Ice & Snow Removal	General Road Tires #113	1,520.00	160493	06/01/2023 1
Bauer Built Tire	Road & Bridge Equipment	Bridgestone Tracks #126	3,790.00	160493	06/01/2023 1
Bauer Built Tire	Airport	11R225 H General Road Tires (4) Airport #319	1,520.00	160723	06/15/2023 1
		Total for Bauer Built Tire	6,830.00		
<u>Beemer Companies</u>					
Beemer Companies	Parks	16' 5/8 Round Park Dept	33.28	160709	06/09/2023 1
		Total for Beemer Companies	33.28		
<u>Bellboy Corporation</u>					
Bellboy Corporation	Liquor Store	Supplies Liquor Store	21.00	160606	06/08/2023 1
Bellboy Corporation	Liquor - Mdse for Resale	Freight	8.92	160606	06/08/2023 1
Bellboy Corporation	Liquor - Mdse for Resale	Misc Merchandise for Resale Liquor Store	-40.00	160606	06/08/2023 1
Bellboy Corporation	Liquor - Mdse for Resale	Liquor	4,497.42	160606	06/08/2023 1
Bellboy Corporation	Liquor - Mdse for Resale	Misc Merchandise for Resale Liquor Store	296.75	160606	06/08/2023 1
Bellboy Corporation	Liquor - Mdse for Resale	Freight	2.00	160606	06/08/2023 1
Bellboy Corporation	Liquor - Mdse for Resale	Freight	84.00	160606	06/08/2023 1
Bellboy Corporation	Liquor - Mdse for Resale	Pop/Mix	72.00	160606	06/08/2023 1
		Total for Bellboy Corporation	4,942.09		
<u>Berhow</u>					
Berhow	Paved Streets	MMUA Competent Person Training Marshall, MN 05/23/2023	41.00	160494	06/01/2023 1
		Total for Berhow	41.00		
<u>Bettin Trucking, Inc.</u>					
Bettin Trucking, Inc.	Paved Streets	Gravel	1,144.85	160495	06/01/2023 1
Bettin Trucking, Inc.	Storm Sewer Mnt	1 1/2" Red Rock Storm Sewer	349.50	160817	06/21/2023 1
		Total for Bettin Trucking, Inc.	1,494.35		
<u>Bevcomm Inc</u>					
Bevcomm Inc	Data Processing	20 Items Recycled Water Plant	400.00	160548	06/02/2023 1
Bevcomm Inc	Data Processing	Microsoft Office Items June 2023	2,585.15	160548	06/02/2023 1
Bevcomm Inc	Data Processing	Computer Related Support Services Contract May 2023	6,394.75	160548	06/02/2023 1
Bevcomm Inc	Data Processing	Rocketfailover Fusion June 2023	39.95	160548	06/02/2023 1
Bevcomm Inc	Data Processing	Patch Cord, Power Strip, HP Care Pack-3 Year (10)	422.62	160548	06/02/2023 1
		Total for Bevcomm Inc	9,842.47		
<u>Blue Earth County Sheriff's Office</u>					

Accounts Payable
Check Approval List - City Council

From: 05/24/2023

To: 06/27/2023



<u>Vendor</u>	<u>Department</u>	<u>Description</u>	<u>Amount</u>	<u>Check Number</u>	<u>Check Date</u>
Blue Earth County Sheriff's Office	Crime Control & Investigation	2023 Annual Shared Records Fee	18,835.00	160818	06/21/2023 1
Blue Earth County Sheriff's Office	Crime Control & Investigation	2023 Annual MDC Fee	6,802.00	160818	06/21/2023 1
		Total for Blue Earth County Sheriff's Office	25,637.00		
<u>Boekett Building Supply</u>					
Boekett Building Supply	Parks	Roof Sealant, Weather & Ice Winter Roof Guard	70.25	160724	06/15/2023 1
Boekett Building Supply	Parks	Heavy Duty Door Closer Park Dept	17.15	160724	06/15/2023 1
		Total for Boekett Building Supply	87.40		
<u>Boltjes, Inc.</u>					
Boltjes, Inc.	Parks	Labor & Materials to install 47 feet of 4 ft chain link fence	6,177.65	160496	06/01/2023 1
		Total for Boltjes, Inc.	6,177.65		
<u>Bolton & Menk, Inc.</u>					
Bolton & Menk, Inc.	Parks	Gomsrud Park Renovations Phase 1	18,497.00	160624	06/09/2023 1
Bolton & Menk, Inc.	Engineering	April 1 to April 28,2023 Interim Engineering Services	2,904.00	160497	06/01/2023 1
		Total for Bolton & Menk, Inc.	21,401.00		
<u>Bomgaars Supply</u>					
Bomgaars Supply	Paved Streets	Letters/Numbers Street Dept	-8.33	160443	05/26/2023 1
Bomgaars Supply	Paved Streets	Letters/Numbers Sign Repair Street Dept	8.33	160443	05/26/2023 1
Bomgaars Supply	Paved Streets	Mouse Traps Street Dept	7.96	160443	05/26/2023 1
Bomgaars Supply	Paved Streets	Letters/Numbers Street Dept	9.52	160443	05/26/2023 1
Bomgaars Supply	Parks	Bits Park Dept	39.99	160443	05/26/2023 1
Bomgaars Supply	Parks	Wire Rope Clips & Rope Park Dept	15.62	160443	05/26/2023 1
Bomgaars Supply	Fire Fighting	Fan Fire Dept	89.99	160443	05/26/2023 1
Bomgaars Supply	Fire Fighting	Lead In Hose, Nozzles, Fasteners Fire Dept	49.79	160443	05/26/2023 1
Bomgaars Supply	Aquatic Park	Concrete Crack Fill Aquatic Park	26.98	160443	05/26/2023 1
		Total for Bomgaars Supply	239.85		
<u>Breakthru Beverage MN Wine & Spirits</u>					
Breakthru Beverage MN Wine & Spirits, LLC	Liquor - Mdse for Resale	Wine	1,116.00	160848	06/21/2023 1
Breakthru Beverage MN Wine & Spirits, LLC	Liquor - Mdse for Resale	Freight	255.62	160848	06/21/2023 1
Breakthru Beverage MN Wine & Spirits, LLC	Liquor - Mdse for Resale	Liquor	12,154.61	160848	06/21/2023 1
Breakthru Beverage MN Wine & Spirits, LLC	Liquor - Mdse for Resale	Freight	-1.85	160607	06/08/2023 1
Breakthru Beverage MN Wine & Spirits, LLC	Liquor - Mdse for Resale	Freight	-11.10	160607	06/08/2023 1
Breakthru Beverage MN Wine & Spirits, LLC	Liquor - Mdse for Resale	Wine	504.00	160607	06/08/2023 1
Breakthru Beverage MN Wine & Spirits, LLC	Liquor - Mdse for Resale	Liquor	-79.99	160607	06/08/2023 1
Breakthru Beverage MN Wine & Spirits, LLC	Liquor - Mdse for Resale	Liquor	4,513.86	160607	06/08/2023 1
Breakthru Beverage MN Wine & Spirits, LLC	Liquor - Mdse for Resale	Freight	83.25	160607	06/08/2023 1
Breakthru Beverage MN Wine & Spirits, LLC	Liquor - Mdse for Resale	Liquor	-80.20	160607	06/08/2023 1
Breakthru Beverage MN Wine & Spirits, LLC	Liquor - Mdse for Resale	Freight	9.25	160607	06/08/2023 1
Breakthru Beverage MN Wine & Spirits, LLC	Liquor - Mdse for Resale	Freight	140.60	160607	06/08/2023 1
Breakthru Beverage MN Wine & Spirits, LLC	Liquor - Mdse for Resale	Pop/Mix	95.84	160607	06/08/2023 1
Breakthru Beverage MN Wine & Spirits, LLC	Liquor - Mdse for Resale	Pop/Mix	119.92	160848	06/21/2023 1
Breakthru Beverage MN Wine & Spirits, LLC	Liquor - Mdse for Resale	Pop/Mix	133.80	160607	06/08/2023 1
Breakthru Beverage MN Wine & Spirits, LLC	Liquor - Mdse for Resale	Freight	7.40	160607	06/08/2023 1
Breakthru Beverage MN Wine & Spirits, LLC	Liquor - Mdse for Resale	Liquor	-405.00	160607	06/08/2023 1

Accounts Payable
Check Approval List - City Council

From: 05/24/2023

To: 06/27/2023



<u>Vendor</u>	<u>Department</u>	<u>Description</u>	<u>Amount</u>	<u>Check Number</u>	<u>Check Date</u>
Breakthru Beverage MN Wine & Spirits, LLC	Liquor - Mdse for Resale	Liquor	9,610.90	160607	06/08/2023 1
Breakthru Beverage MN Wine & Spirits, LLC	Liquor - Mdse for Resale	Freight	-9.25	160607	06/08/2023 1
Breakthru Beverage MN Wine & Spirits, LLC	Liquor - Mdse for Resale	Wine	400.00	160607	06/08/2023 1
Breakthru Beverage MN Wine & Spirits, LLC	Liquor - Mdse for Resale	Liquor	-653.75	160607	06/08/2023 1
Breakthru Beverage MN Wine & Spirits, LLC	Liquor - Mdse for Resale	Freight	9.25	160607	06/08/2023 1
Breakthru Beverage MN Wine & Spirits, LLC	Liquor - Mdse for Resale	Freight	-3.70	160607	06/08/2023 1
Breakthru Beverage MN Wine & Spirits, LLC	Liquor - Mdse for Resale	Freight	5.55	160607	06/08/2023 1
Total for Breakthru Beverage MN Wine & Spirits			27,915.01		
Breitbarth					
Breitbarth	Aquatic Park Charges	Swimming Lessons Refund Session A	90.00	160444	05/26/2023 1
Total for Breitbarth			90.00		
Bryan Rock Products, Inc					
Bryan Rock Products, Inc	Parks	Ag Lime Winnebago Softball Complex	1,212.28	160445	05/26/2023 1
Total for Bryan Rock Products, Inc			1,212.28		
Capital One Trade Credit					
Capital One Trade Credit	Central Garage	Hose Reels for Barn	407.00	160725	06/15/2023 1
Capital One Trade Credit	Parks	2" x 20' 5K LB Winch St Park Dept	64.00	160725	06/15/2023 1
Capital One Trade Credit	Road & Bridge Equipment	Pintle Eye #150	138.68	160725	06/15/2023 1
Total for Capital One Trade Credit			609.68		
Carquest Auto Parts Stores					
Carquest Auto Parts Stores	Crime Control & Investigation	Bulb for Parking Lights Old #8 PD	6.64	160473	05/30/2023 1
Carquest Auto Parts Stores	Parks	Trailer Plug Park #519	12.62	160726	06/15/2023 1
Carquest Auto Parts Stores	Parks	Oil Seal & Bearings #538	42.55	160819	06/21/2023 1
Carquest Auto Parts Stores	Central Garage	2 Wire Connectors	9.48	160498	06/01/2023 1
Carquest Auto Parts Stores	Central Garage	2 Boxes Large Nitrile Gloves	23.78	160726	06/15/2023 1
Carquest Auto Parts Stores	Central Garage	Masking Tape City Shop	26.28	160726	06/15/2023 1
Carquest Auto Parts Stores	Central Garage	1/2" Hose Splicer City Shop	23.84	160819	06/21/2023 1
Carquest Auto Parts Stores	Central Garage	Tire Probe	12.72	160726	06/15/2023 1
Carquest Auto Parts Stores	Fire Fighting	5 Amp Battery Maintainer Fire #10	179.95	160819	06/21/2023 1
Carquest Auto Parts Stores	Fire Fighting	CHRGR DOE Fire #10	33.15	160498	06/01/2023 1
Carquest Auto Parts Stores	Parks	Wheels Park Dept	24.62	160498	06/01/2023 1
Carquest Auto Parts Stores	Parks	Wheel	-21.10	160726	06/15/2023 1
Carquest Auto Parts Stores	Parks	Wheels Park Dept	54.54	160498	06/01/2023 1
Carquest Auto Parts Stores	Parks	Wheel	24.62	160726	06/15/2023 1
Carquest Auto Parts Stores	Parks	Wheel	21.10	160726	06/15/2023 1
Carquest Auto Parts Stores	Parks	Wheel	-24.62	160726	06/15/2023 1
Carquest Auto Parts Stores	Paved Streets	(6) 30W Motor Oil #155	33.18	160726	06/15/2023 1
Carquest Auto Parts Stores	Paved Streets	Hose Clamp & Assemble Hose #172	19.81	160819	06/21/2023 1
Total for Carquest Auto Parts Stores			503.16		
Cemstone Concrete Materials LLC					
Cemstone Concrete Materials LLC	Storm Sewer Mnt	Concrete Storm Sewer 402 E 3rd St	465.50	160474	05/30/2023 1
Cemstone Concrete Materials LLC	Storm Sewer Mnt	2 yds Concrete Storm Sewer 218 Christina	460.50	160727	06/15/2023 1
Cemstone Concrete Materials LLC	Storm Sewer Mnt	Concrete Storm Sewer 218 W Christina	465.50	160474	05/30/2023 1

Accounts Payable
Check Approval List - City Council

From: 05/24/2023

To: 06/27/2023



<u>Vendor</u>	<u>Department</u>	<u>Description</u>	<u>Amount</u>	<u>Check Number</u>	<u>Check Date</u>
Total for Cemstone Concrete Materials LLC			1,391.50		
<u>Certified Crime Fighter</u>					
Certified Crime Fighter	Crime Control & Investigation	Annual Subscriptions 07/01/23 to 06/30/2024	1,848.00	160446	05/26/2023 1
Total for Certified Crime Fighter			1,848.00		
<u>Cintas Corporation</u>					
Cintas Corporation	Aquatic Park	First Aid Supplies Aquatic Park	83.32	160625	06/09/2023 1
Cintas Corporation	Parks	First Aid Supplies Park Dept	48.72	160475	05/30/2023 1
Cintas Corporation	Paved Streets	First Aid Supplies Street Dept	22.38	160475	05/30/2023 1
Total for Cintas Corporation			154.42		
<u>City of Fairmont-Aquatic Park</u>					
City of Fairmont-Aquatic Park	Non-departmental	2023 Startup Cash Aquatic Park	420.00	160447	05/26/2023 1
Total for City of Fairmont-Aquatic Park			420.00		
<u>Cress Refrigeration</u>					
Cress Refrigeration	Fire Fighting	Air Filters Fire Dept	67.32	160626	06/09/2023 1
Total for Cress Refrigeration			67.32		
<u>Crysteel Truck Equipment Inc</u>					
Crysteel Truck Equipment Inc	Ice & Snow Removal	Shaft PD \$279.71 on 04/19/23	435.00	160728	06/15/2023 1
Total for Crysteel Truck Equipment Inc			435.00		
<u>Culligan Water of Fairmont</u>					
Culligan Water of Fairmont	Aquatic Park	Sodium Bicarbonate Pool Chemicals	1,030.00	160710	06/09/2023 1
Culligan Water of Fairmont	Fire Fighting	Water Cooler Rental Fire Dept	12.30	160729	06/15/2023 1
Total for Culligan Water of Fairmont			1,042.30		
<u>D & S Trophies</u>					
D & S Trophies	Crime Control & Investigation	Photo Name Plates for New Hires Police Dept	30.00	160820	06/21/2023 1
D & S Trophies	Crime Control & Investigation	Polo Shirts for Interns	40.36	160627	06/09/2023 1
D & S Trophies	Crime Control & Investigation	Uniforms Police Dept	143.08	160448	05/26/2023 1
Total for D & S Trophies			213.44		
<u>Dahlheimer Beverage</u>					
Dahlheimer Beverage	Liquor - Mdse for Resale	Beer	292.00	160849	06/21/2023 1
Dahlheimer Beverage	Liquor - Mdse for Resale	Beer	2,045.60	160849	06/21/2023 1
Dahlheimer Beverage	Liquor - Mdse for Resale	Beer	38,710.15	160849	06/21/2023 1
Dahlheimer Beverage	Liquor - Mdse for Resale	Pop/Mix	6.25	160849	06/21/2023 1
Dahlheimer Beverage	Liquor - Mdse for Resale	Beer	10,604.10	160849	06/21/2023 1
Dahlheimer Beverage	Liquor - Mdse for Resale	Beer	-24.00	160849	06/21/2023 1
Dahlheimer Beverage	Liquor - Mdse for Resale	Beer	-89.60	160849	06/21/2023 1
Dahlheimer Beverage	Liquor - Mdse for Resale	Liquor	2,845.00	160849	06/21/2023 1
Dahlheimer Beverage	Liquor - Mdse for Resale	Liquor	2,866.20	160608	06/08/2023 1
Dahlheimer Beverage	Liquor - Mdse for Resale	Pop/Mix	23.85	160608	06/08/2023 1
Dahlheimer Beverage	Liquor - Mdse for Resale	Beer	166.75	160849	06/21/2023 1
Dahlheimer Beverage	Liquor - Mdse for Resale	Beer	55,049.30	160608	06/08/2023 1
Total for Dahlheimer Beverage			112,495.60		
<u>Day Plumbing Heating & Cooling, Inc.</u>					
Day Plumbing Heating & Cooling, Inc.	Parks	Cedar Park Installed New Drinking Fountain & Restroom Repairs	1,398.93	160730	06/15/2023 1

Accounts Payable
Check Approval List - City Council



From: 05/24/2023

To: 06/27/2023

<u>Vendor</u>	<u>Department</u>	<u>Description</u>	<u>Amount</u>	<u>Check Number</u>	<u>Check Date</u>
Day Plumbing Heating & Cooling, Inc.	General Government Buildings	Repair City Hall Irrigation System	142.00	160821	06/21/2023 1
Day Plumbing Heating & Cooling, Inc.	Parks	New Water Heater Gomsrud Park	2,229.85	160628	06/09/2023 1
Day Plumbing Heating & Cooling, Inc.	Parks	Installed the replacement bubbler on Goms Shelter House Fountain	499.75	160499	06/01/2023 1
		Total for Day Plumbing Heating & Cooling, Inc.	4,270.53		
<u>Denny</u>					
Denny	Fire Fighting	Ship Gear to Turnout Mgmt 06/06/2023	13.60	160629	06/09/2023 1
Denny	Crime Control & Investigation	Ship Pkg to Radarsign LLC, Marietta GA 05/25/2023	93.60	160549	06/02/2023 1
		Total for Denny	107.20		
<u>Diamond Vogel Paints</u>					
Diamond Vogel Paints	Paved Streets	Gun Cable, Wheel Cable Sign Dept	116.78	160731	06/15/2023 1
		Total for Diamond Vogel Paints	116.78		
<u>Duderstadt, Jr.</u>					
Duderstadt, Jr.	Local Access	May 2023 City Council Meetings	112.50	160449	05/26/2023 1
		Total for Duderstadt, Jr.	112.50		
<u>Dulcimer Medical Center</u>					
Dulcimer Medical Center	Paved Streets	random drug and alcohol DOT test-street	74.30	160423	05/25/2023 1
Dulcimer Medical Center	Crime Control & Investigation	preemployment physical-police	645.79	160423	05/25/2023 1
Dulcimer Medical Center	Crime Control & Investigation	New Hire Physical Cromwell	617.60	160630	06/09/2023 1
Dulcimer Medical Center	Crime Control & Investigation	New Hire Physical Slater	617.60	160630	06/09/2023 1
Dulcimer Medical Center	Fire Fighting	Fireman Physical R Wokasch	573.87	160822	06/21/2023 1
Dulcimer Medical Center	Fire Fighting	Fireman Physical Nawrocki	556.64	160630	06/09/2023 1
Dulcimer Medical Center	Fire Fighting	Fireman Physical Brooks	556.64	160630	06/09/2023 1
		Total for Dulcimer Medical Center	3,642.44		
<u>Eagle Engraving, Inc.</u>					
Eagle Engraving, Inc.	Fire Fighting	Badges Fire Dept	573.32	160823	06/21/2023 1
		Total for Eagle Engraving, Inc.	573.32		
<u>Elan Financial Services</u>					
Elan Financial Services	Parks	2P GFCI Bolt on Circuit Breaker Park/Street	91.27	160711	06/09/2023 1
Elan Financial Services	Crime Control & Investigation	BCA Training Kotewa & Hagert 05/16/23	150.00	160711	06/09/2023 1
Elan Financial Services	Crime Control & Investigation	Overhead Door Belts (Impound), Large Live Trap	131.81	160711	06/09/2023 1
Elan Financial Services	Crime Control & Investigation	Justin Jobe POST License Renewal	90.00	160711	06/09/2023 1
Elan Financial Services	Crime Control & Investigation	Tire Gauges for Squads	15.45	160711	06/09/2023 1
Elan Financial Services	Crime Control & Investigation	Use of Force Equipment Storage Bags	27.99	160711	06/09/2023 1
Elan Financial Services	Recording & Reporting	International Institute of Municipal Clerks Conf Minneapolis, MN	706.96	160711	06/09/2023 1
Elan Financial Services	Aquatic Park	Operating Supplies Aquatic Park	225.41	160711	06/09/2023 1
Elan Financial Services	Aquatic Park	Staff Uniforms Aquatic Park	889.94	160711	06/09/2023 1
Elan Financial Services	Aquatic Park	Online Scheduling at WhentoWork.com for 6 month subscription	312.00	160711	06/09/2023 1
Elan Financial Services	Aquatic Park	Merchandise for Resale Aquatic Park	149.85	160711	06/09/2023 1
Elan Financial Services	Aquatic Park	Cleaning Supplies Aquatic Park	32.51	160711	06/09/2023 1
Elan Financial Services	Aquatic Park	Equipment Parts Aquatic Park A-71 Cover, X Hose, Pump	679.14	160711	06/09/2023 1
Elan Financial Services	Aquatic Park	Test Online Swimming Lessons Pymnt	1.12	160711	06/09/2023 1
Elan Financial Services	Paved Streets	2P GFCI Bolt on Circuit Breaker Park/Street	91.26	160711	06/09/2023 1
Elan Financial Services	Airport	Airport Conference Steinkamp Alexandria, MN 04/26 to 04/27/23	258.20	160711	06/09/2023 1

Accounts Payable
Check Approval List - City Council

From: 05/24/2023

To: 06/27/2023



<u>Vendor</u>	<u>Department</u>	<u>Description</u>	<u>Amount</u>	<u>Check Number</u>	<u>Check Date</u>
Total for Elan Financial Services			3,852.91		
<u>Emergency Apparatus Maintenance, In</u>					
Emergency Apparatus Maintenance, Inc.	Fire Fighting	Engine #1 NFPA Pump Test, Service Pump, Service Foam System	928.45	160732	06/15/2023 1
Emergency Apparatus Maintenance, Inc.	Fire Fighting	Tanker Township #2 NFPA Pump Test, Service Pump Per EAM Report	754.55	160732	06/15/2023 1
Emergency Apparatus Maintenance, Inc.	Fire Fighting	Ladder #8 NFPA Pump Test, Service Pump, Service Generator,Aerial	3,182.70	160732	06/15/2023 1
Emergency Apparatus Maintenance, Inc.	Fire Fighting	Pump had a failure during inspection Tanker #2 Repair as Neces	10,883.04	160824	06/21/2023 1
Emergency Apparatus Maintenance, Inc.	Fire Fighting	Engine #3 NFPA Pump Test, Service Pump, Service Foam System	1,167.23	160732	06/15/2023 1
Emergency Apparatus Maintenance, Inc.	Fire Fighting	Rescue HD Rescue Service Hydraulic Generator/Oil Sample Analysis	607.30	160732	06/15/2023 1
Total for Emergency Apparatus Maintenance, In			17,523.27		
<u>Equifax Information Services, LLC</u>					
Equifax Information Services, LLC	General Government Buildings	Minimum Charge & Monthly Service Fee May 2023	57.50	160550	06/02/2023 1
Total for Equifax Information Services, LLC			57.50		
<u>Erickson Engineering</u>					
Erickson Engineering	Paved Streets	Memorial Park Drive Bridge Services May 2023	9,076.50	160733	06/15/2023 1
Total for Erickson Engineering			9,076.50		
<u>Fairmont Chamber of Commerce</u>					
Fairmont Chamber of Commerce	Economic Development	Fairmont Area Life	1,500.00	160734	06/15/2023 1
Fairmont Chamber of Commerce	Economic Development	2023 Chamber Golf Outing	280.00	160500	06/01/2023 1
Total for Fairmont Chamber of Commerce			1,780.00		
<u>Fairmont Ford</u>					
Fairmont Ford	Crime Control & Investigation	Diagnose Squad #6 Codes & Other Issues After Pursuit	190.19	160631	06/09/2023 1
Total for Fairmont Ford			190.19		
<u>Fairmont Glass</u>					
Fairmont Glass	Parks	Replace Screen In Door Sylvania Park	39.45	160712	06/09/2023 1
Fairmont Glass	Parks	2 Pieces Polycarb Glass For Side Shield For Lawn Mower	94.52	160735	06/15/2023 1
Total for Fairmont Glass			133.97		
<u>Fairmont Sentinel</u>					
Fairmont Sentinel	Parks	1 year subscription 06/12/2023 to 06/10/2024 Park Dept	278.40	160476	05/30/2023 1
Fairmont Sentinel	Planning & Zoning	Notice of Public Hearing Variance Requests Halstad/UHD	87.00	160551	06/02/2023 1
Fairmont Sentinel	Planning & Zoning	Notice of Public Hearing Variance Requests	87.00	160551	06/02/2023 1
Fairmont Sentinel	Planning & Zoning	Notice of Public Hearing Fairmont Growth & Opportunity & Midwest	76.13	160501	06/01/2023 1
Fairmont Sentinel	Aquatic Park	Lifeguards Help Wanted Ads	915.60	160736	06/15/2023 1
Fairmont Sentinel	Paved Streets	1 year subscription 06/12/2023 to 06/10/2024 Street Dept	278.40	160476	05/30/2023 1
Fairmont Sentinel	Liquor Store	Liquor Store Ad	175.00	160736	06/15/2023 1
Total for Fairmont Sentinel			1,897.53		
<u>Fairmont True Value</u>					
Fairmont True Value	Parks	Tube Caulk, Fly Swatters, Hose Adapter	19.64	160737	06/15/2023 1
Fairmont True Value	Parks	3 Cans of Spray Primer Park Dept	34.47	160737	06/15/2023 1
Fairmont True Value	Parks	Cleaning Supplies Park Dept	33.06	160825	06/21/2023 1
Total for Fairmont True Value			87.17		
<u>Families First</u>					
Families First	Non-departmental	AR Refund	50.00	160450	05/26/2023 1
Total for Families First			50.00		

Accounts Payable
Check Approval List - City Council

From: 05/24/2023

To: 06/27/2023



<u>Vendor</u>	<u>Department</u>	<u>Description</u>	<u>Amount</u>	<u>Check Number</u>	<u>Check Date</u>
<u>Fastenal Company</u>					
Fastenal Company	Road & Bridge Equipment	Plastic Door Handle Street Dept #167	11.70	160826	06/21/2023 1
Fastenal Company	Parks	Coil St Link 4/0 Park Dept	317.80	160826	06/21/2023 1
Fastenal Company	Parks	Equipment Parts Park Dept	49.78	160738	06/15/2023 1
Fastenal Company	Central Garage	Equipment Parts City Shop	27.88	160738	06/15/2023 1
Fastenal Company	Central Garage	Shop Materials	56.32	160738	06/15/2023 1
Fastenal Company	Central Garage	Shop Supplies	73.83	160477	05/30/2023 1
		Total for Fastenal Company	537.31		
<u>Federated Rural Electric Association</u>					
Federated Rural Electric Association	Airport	Electric Utilities 04/30 to 05/31/2023 Airport	33.86	160739	06/15/2023 1
		Total for Federated Rural Electric Association	33.86		
<u>Fire Safety USA, Inc.</u>					
Fire Safety USA, Inc.	Fire Fighting	Mini Quick Fist Clamp 24 Pack Fire Dept	95.00	160862	06/27/2023 1
		Total for Fire Safety USA, Inc.	95.00		
<u>Flaherty & Hood P.A.</u>					
Flaherty & Hood P.A.	Other General Gov't	General Municipal Matters May 2023	9,006.25	160740	06/15/2023 1
Flaherty & Hood P.A.	Other General Gov't	Labor & Employment Services May 2023	108.75	160740	06/15/2023 1
		Total for Flaherty & Hood P.A.	9,115.00		
<u>Fleet & Farm Supply</u>					
Fleet & Farm Supply	Parks	Hose Fitting, Valve, Wrenches	45.34	160713	06/09/2023 1
Fleet & Farm Supply	Parks	1/2" DRV Metric Socket Tray	11.99	160713	06/09/2023 1
Fleet & Farm Supply	Parks	Bldg Repairs Park Dept	14.58	160713	06/09/2023 1
Fleet & Farm Supply	Parks	Potting Soil Park Dept	19.96	160713	06/09/2023 1
Fleet & Farm Supply	Aquatic Park	Drywall & Probe Set	28.98	160713	06/09/2023 1
Fleet & Farm Supply	Aquatic Park	Building Repair Supplies	25.98	160713	06/09/2023 1
Fleet & Farm Supply	Aquatic Park	Building Repair Supplies Aquatic Park	85.97	160713	06/09/2023 1
Fleet & Farm Supply	Liquor Store	Red Mulch Liquor Store	30.00	160713	06/09/2023 1
Fleet & Farm Supply	Liquor Store	Supplies Liquor Store	29.75	160713	06/09/2023 1
Fleet & Farm Supply	Airport	Flush Valve Repair Kit Airport	10.99	160713	06/09/2023 1
Fleet & Farm Supply	Liquor Store	Red Mulch Liquor Store	50.00	160713	06/09/2023 1
Fleet & Farm Supply	Liquor Store	Red Mulch Liquor Store	75.00	160713	06/09/2023 1
Fleet & Farm Supply	Paved Streets	Line String, Torch Fuel	38.97	160713	06/09/2023 1
Fleet & Farm Supply	Paved Streets	Putty Knives & Funnel Street Dept	47.94	160713	06/09/2023 1
Fleet & Farm Supply	Animal Control	Supplies for HVAC Repair Humane Society	13.36	160713	06/09/2023 1
		Total for Fleet & Farm Supply	528.81		
<u>Forstrom</u>					
Forstrom	Non-departmental	Refund Check 017467-000, 1331 Johnson St #C	0.35	160580	06/02/2023 1
Forstrom	Non-departmental	Refund Check 017467-000, 1331 Johnson St #C	3.85	160580	06/02/2023 1
Forstrom	Non-departmental	Refund Check 017467-000, 1331 Johnson St #C	3.85	160580	06/02/2023 1
Forstrom	Non-departmental	Refund Check 017467-000, 1331 Johnson St #C	2.57	160580	06/02/2023 1
		Total for Forstrom	10.62		
<u>Freeman</u>					
Freeman	Non-departmental	Refund Check 018365-001, 1319 Johnson St #E	3.77	160581	06/02/2023 1

**Accounts Payable
Check Approval List - City Council**

From: 05/24/2023

To: 06/27/2023



<u>Vendor</u>	<u>Department</u>	<u>Description</u>	<u>Amount</u>	<u>Check Number</u>	<u>Check Date</u>
Freeman	Non-departmental	Refund Check 018365-001, 1319 Johnson St #E	3.77	160581	06/02/2023 1
Freeman	Non-departmental	Refund Check 018365-001, 1319 Johnson St #E	2.51	160581	06/02/2023 1
Freeman	Non-departmental	Refund Check 018365-001, 1319 Johnson St #E	0.38	160581	06/02/2023 1
		Total for Freeman	10.43		
Frontier Communications					
Frontier Communications	Animal Control	June 2023 Telephone Humane Society	180.49	160714	06/09/2023 1
Frontier Communications	Airport	Airport Card Reader Line	46.40	160714	06/09/2023 1
		Total for Frontier Communications	226.89		
FullStack					
FullStack	Crime Control & Investigation	Quarterly Hosting of http://fairmontpolice.org (Jun to Aug 2023)	87.00	160632	06/09/2023 1
		Total for FullStack	87.00		
Galls, LLC					
Galls, LLC	Crime Control & Investigation	Uniforms Police Dept	265.16	160552	06/02/2023 1
		Total for Galls, LLC	265.16		
Game Time Athletics					
Game Time Athletics	Parks	Hollywood Impact Bases-Set of 3	616.78	160633	06/09/2023 1
		Total for Game Time Athletics	616.78		
Gemini Studios					
Gemini Studios	Local Access	June 2023 Local Access Channel & Boxcast Annual Membership	600.00	160553	06/02/2023 1
Gemini Studios	Local Access	June 2023 Operation of Audio & Video Broadcast Equipment	450.00	160553	06/02/2023 1
		Total for Gemini Studios	1,050.00		
Gillette Pepsi Companies Inc.					
Gillette Pepsi Companies Inc.	Liquor - Mdse for Resale	Pop/Mix	431.20	160609	06/08/2023 1
Gillette Pepsi Companies Inc.	Liquor - Mdse for Resale	Pop/Mix	330.20	160609	06/08/2023 1
Gillette Pepsi Companies Inc.	Aquatic Park	Pop for Resale Aquatic Park	1,837.80	160502	06/01/2023 1
Gillette Pepsi Companies Inc.	Aquatic Park	Beverage for Resale Aquatic Park	344.30	160827	06/21/2023 1
Gillette Pepsi Companies Inc.	Aquatic Park	Beverages for Resale Aquatic Park	1,225.80	160863	06/27/2023 1
		Total for Gillette Pepsi Companies Inc.	4,169.30		
GMS Industrial Supplies, Inc.					
GMS Industrial Supplies, Inc.	Parks	1/2-13 Grade 8 Nylock Yellow Zinc Docks	8.92	160503	06/01/2023 1
GMS Industrial Supplies, Inc.	Central Garage	Mechanic's Nits & Hex Screws City Shop	98.66	160741	06/15/2023 1
		Total for GMS Industrial Supplies, Inc.	107.58		
Gopher					
Gopher	Parks	Pickle Ball Net	257.60	160554	06/02/2023 1
		Total for Gopher	257.60		
Gopher Alarms, LLC					
Gopher Alarms, LLC	Parks	Alarm Monitoring April to June 2023 Park/Street Dept	36.00	160451	05/26/2023 1
Gopher Alarms, LLC	General Government Buildings	Alarm Monitoring City Hall April to June 2023	48.00	160451	05/26/2023 1
Gopher Alarms, LLC	General Government Buildings	Alarm Monitoring April to June 2023 Martin County Arena	72.00	160478	05/30/2023 1
Gopher Alarms, LLC	SMEC Building	Alarm Monitoring April to June 2023 SMEC	72.00	160451	05/26/2023 1
Gopher Alarms, LLC	Library	Alarm Monitoring April to June 2023 Library	72.00	160451	05/26/2023 1
Gopher Alarms, LLC	Liquor Store	Alarm Monitoring Fire & Burglar April to June 2023 Liquor Store	120.00	160451	05/26/2023 1
Gopher Alarms, LLC	Paved Streets	Alarm Monitoring April to June 2023 Park/Street Dept	36.00	160451	05/26/2023 1

Accounts Payable
Check Approval List - City Council



From: 05/24/2023

To: 06/27/2023

<u>Vendor</u>	<u>Department</u>	<u>Description</u>	<u>Amount</u>	<u>Check Number</u>	<u>Check Date</u>
Total for Gopher Alarms, LLC			456.00		
<u>GovHR USA, LLC</u>					
GovHR USA, LLC	Other General Gov't	Recruitment Fmt City Administrator 1/3	8,600.00	160634	06/09/2023 1
Total for GovHR USA, LLC			8,600.00		
<u>Graham Tire Company</u>					
Graham Tire Company	Fiscal Sponsor	Install Tires & New Valve Stem MRAP HEAT Team	500.00	160479	05/30/2023 1
Total for Graham Tire Company			500.00		
<u>Green Care</u>					
Green Care	Parks	Irrigation Service 900 Johnson St	160.00	160828	06/21/2023 1
Total for Green Care			160.00		
<u>Harrison</u>					
Harrison	Non-departmental	Refund Check 018320-000, 224 1/2 S Park #3	5.03	160582	06/02/2023 1
Harrison	Non-departmental	Refund Check 018320-000, 224 1/2 S Park #3	0.50	160582	06/02/2023 1
Harrison	Non-departmental	Refund Check 018320-000, 224 1/2 S Park #3	3.33	160582	06/02/2023 1
Harrison	Non-departmental	Refund Check 018320-000, 224 1/2 S Park #3	5.03	160582	06/02/2023 1
Total for Harrison			13.89		
<u>Hart</u>					
Hart	Non-departmental	Refund Check 009050-000, 2714 Albion Ave	5.03	160583	06/02/2023 1
Hart	Non-departmental	Refund Check 009050-000, 2714 Albion Ave	12.83	160583	06/02/2023 1
Hart	Non-departmental	Refund Check 009050-000, 2714 Albion Ave	3.25	160583	06/02/2023 1
Hart	Non-departmental	Refund Check 009050-000, 2714 Albion Ave	0.10	160583	06/02/2023 1
Hart	Non-departmental	Refund Check 009050-000, 2714 Albion Ave	3.34	160583	06/02/2023 1
Hart	Non-departmental	Refund Check 009050-000, 2714 Albion Ave	2.00	160583	06/02/2023 1
Total for Hart			26.55		
<u>Hawkins, Inc.</u>					
Hawkins, Inc.	Aquatic Park	Chemicals Aquatic Park	1,691.90	160742	06/15/2023 1
Hawkins, Inc.	Aquatic Park	Pool Chemicals	604.73	160635	06/09/2023 1
Total for Hawkins, Inc.			2,296.63		
<u>Hennager</u>					
Hennager	Non-departmental	Refund Check 018046-000, 1511 Falcon Dr #109	0.06	160584	06/02/2023 1
Hennager	Non-departmental	Refund Check 018046-000, 1511 Falcon Dr #109	0.11	160584	06/02/2023 1
Hennager	Non-departmental	Refund Check 018046-000, 1511 Falcon Dr #109	0.11	160584	06/02/2023 1
Total for Hennager			0.28		
<u>Hermann</u>					
Hermann	Non-departmental	Refund Check 013917-002, 1305 Johnson St #D	1.25	160585	06/02/2023 1
Hermann	Non-departmental	Refund Check 013917-002, 1305 Johnson St #D	0.18	160585	06/02/2023 1
Hermann	Non-departmental	Refund Check 013917-002, 1305 Johnson St #D	1.87	160585	06/02/2023 1
Hermann	Non-departmental	Refund Check 013917-002, 1305 Johnson St #D	1.87	160585	06/02/2023 1
Total for Hermann			5.17		
<u>Hertzke Construction & Millwork, Inc.</u>					
Hertzke Construction & Millwork, Inc.	Fire Fighting	Equipment Repairs Fire Dept	41.57	160555	06/02/2023 1
Total for Hertzke Construction & Millwork, Inc.			41.57		
<u>Hildi, Inc.</u>					

**Accounts Payable
Check Approval List - City Council**

From: 05/24/2023

To: 06/27/2023



<u>Vendor</u>	<u>Department</u>	<u>Description</u>	<u>Amount</u>	<u>Check Number</u>	<u>Check Date</u>
Hildi, Inc.	Other General Gov't	Actuarial Valuation under GASB 75 services through 03/29/2023	1,300.00	160480	05/30/2023 1
Total for Hildi, Inc.			1,300.00		
<u>Hoffman Filter Service, LLC</u>					
Hoffman Filter Service, LLC	Central Garage	Used Oil Filters	65.00	160743	06/15/2023 1
Total for Hoffman Filter Service, LLC			65.00		
<u>Home City Ice Co.</u>					
Home City Ice Co.	Liquor - Mdse for Resale	Ice	456.15	160610	06/08/2023 1
Home City Ice Co.	Liquor - Mdse for Resale	Ice	448.90	160610	06/08/2023 1
Home City Ice Co.	Liquor - Mdse for Resale	Ice	104.60	160610	06/08/2023 1
Home City Ice Co.	Liquor - Mdse for Resale	Ice	170.10	160610	06/08/2023 1
Total for Home City Ice Co.			1,179.75		
<u>Hometown Sanitation Services, LLC</u>					
Hometown Sanitation Services, LLC	Liquor Store	Cardboard Pickup Liquor Store June 2023	87.99	160715	06/09/2023 1
Hometown Sanitation Services, LLC	SMEC Building	June 2023 Refuse Removal SMEC	142.00	160636	06/09/2023 1
Total for Hometown Sanitation Services, LLC			229.99		
<u>Horizon Commercial Pool Supply</u>					
Horizon Commercial Pool Supply	Aquatic Park	Pump Service Kit Aquatic Park	198.39	160744	06/15/2023 1
Total for Horizon Commercial Pool Supply			198.39		
<u>Hoye</u>					
Hoye	Director of Finance	GFOA Conference Portland, OR 05/20 to 05/24/2023	1,779.34	0	05/26/2023 1
Total for Hoye			1,779.34		
<u>Hughes</u>					
Hughes	Other General Gov't	House Demo 819 Reiman Ct	3,046.50	160504	06/01/2023 1
Total for Hughes			3,046.50		
<u>Humana</u>					
Humana	Health Insurance	May 2023 Life Insurance Premiums	327.70	0	06/12/2023 1
Total for Humana			327.70		
<u>Hy Vee Food Store</u>					
Hy Vee Food Store	Aquatic Park	Misc Operating Supplies Aquatic Park	44.42	160864	06/27/2023 1
Hy Vee Food Store	Aquatic Park	Food for Resale Aquatic Park	19.44	160864	06/27/2023 1
Hy Vee Food Store	Crime Control & Investigation	Supplies for Bryan Boltjes Retirement	161.06	160452	05/26/2023 1
Total for Hy Vee Food Store			224.92		
<u>Independent Pest Control</u>					
Independent Pest Control	SMEC Building	June 2023 Pest Control SMEC	56.00	160637	06/09/2023 1
Independent Pest Control	Aquatic Park	June 2023 Pest Control Aquatic Park	65.00	160637	06/09/2023 1
Independent Pest Control	General Government Buildings	June 2023 Pest Control City Hall	56.00	160637	06/09/2023 1
Independent Pest Control	Airport	June 2023 Pest Control Airport	110.00	160745	06/15/2023 1
Independent Pest Control	Library	June 2023 Pest Control Library	56.00	160637	06/09/2023 1
Total for Independent Pest Control			343.00		
<u>Indian Island Winery LLC</u>					
Indian Island Winery LLC	Liquor - Mdse for Resale	Wine	938.88	160850	06/21/2023 1
Total for Indian Island Winery LLC			938.88		
<u>J Hokanson Print</u>					

Accounts Payable
Check Approval List - City Council



From: 05/24/2023

To: 06/27/2023

<u>Vendor</u>	<u>Department</u>	<u>Description</u>	<u>Amount</u>	<u>Check Number</u>	<u>Check Date</u>
J Hokanson Print	Parking Lots	White Epiphany Pen	16.78	160746	06/15/2023 1
J Hokanson Print	Data Processing	White Epiphany Pen	25.17	160746	06/15/2023 1
J Hokanson Print	Airport	White Epiphany Pen	41.95	160746	06/15/2023 1
J Hokanson Print	Liquor Store	White Epiphany Pen	16.78	160746	06/15/2023 1
J Hokanson Print	Building Inspection	White Epiphany Pen	41.95	160746	06/15/2023 1
J Hokanson Print	Paved Streets	White Epiphany Pen	16.78	160746	06/15/2023 1
J Hokanson Print	Economic Development	White Epiphany Pen	25.17	160746	06/15/2023 1
J Hokanson Print	Engineering	White Epiphany Pen	92.29	160746	06/15/2023 1
J Hokanson Print	Director of Finance	Accts Payable Checks	274.07	160453	05/26/2023 1
J Hokanson Print	Director of Finance	White Epiphany Pen	41.95	160746	06/15/2023 1
J Hokanson Print	Fire Fighting	White Epiphany Pen	33.56	160746	06/15/2023 1
J Hokanson Print	City Manager	White Epiphany Pen	41.95	160746	06/15/2023 1
J Hokanson Print	Parks	White Epiphany Pen	33.56	160746	06/15/2023 1
J Hokanson Print	Planning & Zoning	White Epiphany Pen	41.95	160746	06/15/2023 1
J Hokanson Print	Police Administration	White Epiphany Pen	16.78	160746	06/15/2023 1
J Hokanson Print	Recording & Reporting	White Epiphany Pen	41.95	160746	06/15/2023 1
J Hokanson Print	Lake Restoration	White Epiphany Pen	16.78	160746	06/15/2023 1
J Hokanson Print	Crime Control & Investigation	White Epiphany Pen	25.17	160746	06/15/2023 1
Total for J Hokanson Print			844.59		
<u>J. H. Larson</u>					
J. H. Larson	Parks	120 V Plug-In Circuit Breaker Hot Water Heater Gomsrud	8.56	160716	06/09/2023 1
J. H. Larson	Parks	Supplies for Water Heater Gomsrud	465.16	160638	06/09/2023 1
J. H. Larson	Parks	Sylvania Outlet for Beer Garden IHD Days	88.09	160716	06/09/2023 1
J. H. Larson	Parks	Sylvania BandShell Lights LED	720.96	160716	06/09/2023 1
J. H. Larson	Liquor Store	70W Medium Base Pulse Start Lamp Liquor Store	-106.30	160454	05/26/2023 1
J. H. Larson	Airport	Receptacle Box Cover 20 or 30A Twist Lock Power Washer Airport	4.12	160747	06/15/2023 1
J. H. Larson	Airport	Electrical Parts for Power Washer Plug In Airport	225.19	160747	06/15/2023 1
J. H. Larson	Airport	LED & HID Rated 6A Photo Control W Surge Protection Airport	57.99	160865	06/27/2023 1
J. H. Larson	Airport	T5 LED Bulbs Airport	61.32	160454	05/26/2023 1
J. H. Larson	Airport	2P 30A 240V GFCI Low Voltage Molded Case Circuit Breakers Airpor	156.43	160865	06/27/2023 1
J. H. Larson	Airport	2P 30A 240V GFCI Low Voltage Molded Case Circuit Breakers Airpor	-156.43	160865	06/27/2023 1
J. H. Larson	Airport	Starter Hangar Door Opener Airport	564.93	160865	06/27/2023 1
J. H. Larson	Library	Flourescent Lamps Library	145.95	160638	06/09/2023 1
J. H. Larson	Liquor Store	25T/LED Mini Lamps Liquor Store Return	-31.47	160638	06/09/2023 1
J. H. Larson	Liquor Store	32W Triple Twin Tube Lamp Liquor Store	58.90	160454	05/26/2023 1
J. H. Larson	Liquor Store	70W Medium Base Pulse Start Lamp Liquor Store	42.52	160454	05/26/2023 1
Total for J. H. Larson			2,305.92		
<u>Jackson County Sheriff's Office</u>					
Jackson County Sheriff's Office	Fiscal Sponsor	HEAT Team Fuel May 2023	67.01	160639	06/09/2023 1
Total for Jackson County Sheriff's Office			67.01		
<u>Janzen Greenhouses</u>					
Janzen Greenhouses	Parks	Perennial Plants Park Dept	74.95	160829	06/21/2023 1
Total for Janzen Greenhouses			74.95		

Accounts Payable
Check Approval List - City Council

From: 05/24/2023

To: 06/27/2023



<u>Vendor</u>	<u>Department</u>	<u>Description</u>	<u>Amount</u>	<u>Check Number</u>	<u>Check Date</u>
<u>Jefferson Fire & Safety, Inc.</u>					
Jefferson Fire & Safety, Inc.	Fire Fighting	Streamlight Survivor X Right Angle LED Light-Rechargeable	78.20	160748	06/15/2023 1
		Total for Jefferson Fire & Safety, Inc.	78.20		
<u>Johnson Brothers Liquor Company</u>					
Johnson Brothers Liquor Company	Liquor - Mdse for Resale	Freight	795.80	160851	06/21/2023 1
Johnson Brothers Liquor Company	Liquor - Mdse for Resale	Liquor	9,917.42	160611	06/08/2023 1
Johnson Brothers Liquor Company	Liquor - Mdse for Resale	Wine	6,143.25	160851	06/21/2023 1
Johnson Brothers Liquor Company	Liquor - Mdse for Resale	Freight	1.98	160611	06/08/2023 1
Johnson Brothers Liquor Company	Liquor - Mdse for Resale	Freight	100.98	160611	06/08/2023 1
Johnson Brothers Liquor Company	Liquor - Mdse for Resale	Wine	6,709.66	160611	06/08/2023 1
Johnson Brothers Liquor Company	Liquor - Mdse for Resale	Pop/Mix	122.00	160611	06/08/2023 1
Johnson Brothers Liquor Company	Liquor - Mdse for Resale	Liquor	83.75	160611	06/08/2023 1
Johnson Brothers Liquor Company	Liquor - Mdse for Resale	Pop/Mix	112.00	160851	06/21/2023 1
Johnson Brothers Liquor Company	Liquor - Mdse for Resale	Pop/Mix	154.00	160611	06/08/2023 1
Johnson Brothers Liquor Company	Liquor - Mdse for Resale	Freight	6.28	160611	06/08/2023 1
Johnson Brothers Liquor Company	Liquor - Mdse for Resale	Freight	7.92	160611	06/08/2023 1
Johnson Brothers Liquor Company	Liquor - Mdse for Resale	Liquor	30,924.42	160851	06/21/2023 1
Johnson Brothers Liquor Company	Liquor - Mdse for Resale	Wine	3,084.90	160611	06/08/2023 1
Johnson Brothers Liquor Company	Liquor - Mdse for Resale	Freight	194.72	160611	06/08/2023 1
Johnson Brothers Liquor Company	Liquor - Mdse for Resale	Liquor	5,452.45	160611	06/08/2023 1
Johnson Brothers Liquor Company	Liquor - Mdse for Resale	Freight	193.39	160611	06/08/2023 1
Johnson Brothers Liquor Company	Liquor - Mdse for Resale	Freight	99.00	160611	06/08/2023 1
		Total for Johnson Brothers Liquor Company	64,103.92		
<u>Kahler Electric</u>					
Kahler Electric	Library	5/15/23 Extend Wires to Exhaust Fan on Roof	993.59	160556	06/02/2023 1
		Total for Kahler Electric	993.59		
<u>Kaufman Trailers, LLC</u>					
Kaufman Trailers, LLC	Paved Streets	Deluxe Deck Over Paver Trailer Street Dept	17,150.00	160505	06/01/2023 1
		Total for Kaufman Trailers, LLC	17,150.00		
<u>Koppen</u>					
Koppen	Economic Development	June 2023 Cell Phone Reimbursement	46.44	0	06/09/2023 1
		Total for Koppen	46.44		
<u>Lawn Solutions, Inc</u>					
Lawn Solutions, Inc	Weed Control	Mow & Trim 425 E 3rd St 06/09/23	53.60	160749	06/15/2023 1
Lawn Solutions, Inc	Weed Control	Mow & Trim 724 E 1st St 06/09/2023	93.60	160749	06/15/2023 1
Lawn Solutions, Inc	Weed Control	Mow & Trim 713 E 4th St 06/09/2023	60.00	160749	06/15/2023 1
Lawn Solutions, Inc	Weed Control	Mow & Trim 112 & 114 W 4th St 06/09/23	66.40	160749	06/15/2023 1
Lawn Solutions, Inc	Weed Control	Mow & Trim 410 N Prairie Ave 06/09/23	80.00	160749	06/15/2023 1
Lawn Solutions, Inc	Weed Control	Mow & Trim 403 E 5th St 06/09/2023	60.00	160749	06/15/2023 1
Lawn Solutions, Inc	Weed Control	Mow & Trim 332 Lake Ave 06/09/23	73.60	160749	06/15/2023 1
Lawn Solutions, Inc	Weed Control	Mow & Trim 401 Downtown Plaza 06/09/23	66.40	160749	06/15/2023 1
Lawn Solutions, Inc	Parks	Spring Fertilizer Application Soccer Fields	5,863.00	160749	06/15/2023 1
Lawn Solutions, Inc	SMEC Building	Invoice 2 of 7 Mowing & Trimming SMEC June 2023	510.00	160506	06/01/2023 1

Accounts Payable
Check Approval List - City Council

From: 05/24/2023

To: 06/27/2023



<u>Vendor</u>	<u>Department</u>	<u>Description</u>	<u>Amount</u>	<u>Check Number</u>	<u>Check Date</u>
Lawn Solutions, Inc	SMEC Building	Weed Control W/ Fertilizer Step 2 SMEC	192.00	160455	05/26/2023 1
Total for Lawn Solutions, Inc			7,118.60		
<u>Lexis Nexis Risk Data Management, LL</u>					
Lexis Nexis Risk Data Management, LLC	Other General Gov't	May 2023 Monthly Subscription Fee	106.09	160640	06/09/2023 1
Total for Lexis Nexis Risk Data Management, LL			106.09		
<u>License Bureau</u>					
License Bureau	Fire Fighting	#7 Fire Truck registration	27.00	160428	05/25/2023 1
License Bureau	Crime Control & Investigation	title transfer of old squad 1 now squad 8 VIN ends is 83770	27.00	160532	06/01/2023 1
License Bureau	Paved Streets	License & Fees Street Dept Trailer 7UZFH2525PB000660	1,162.00	160776	06/15/2023 1
Total for License Bureau			1,216.00		
<u>Light, Noise & Smoke Of Fairmont</u>					
Light, Noise & Smoke Of Fairmont	Other General Gov't	Annual Fireworks Display Donation	1,500.00	160750	06/15/2023 1
Total for Light, Noise & Smoke Of Fairmont			1,500.00		
<u>Locators & Supplies, Inc</u>					
Locators & Supplies, Inc	Parks	Safety Vests	176.89	160830	06/21/2023 1
Locators & Supplies, Inc	Parks	Gloves Park/Street Dept	176.55	160481	05/30/2023 1
Locators & Supplies, Inc	Parks	Keystone Driver Gloves	158.45	160830	06/21/2023 1
Locators & Supplies, Inc	Paved Streets	Safety Vests	176.89	160830	06/21/2023 1
Locators & Supplies, Inc	Paved Streets	Gloves Park/Street Dept	176.55	160481	05/30/2023 1
Total for Locators & Supplies, Inc			865.33		
<u>Lockridge Grindal Nauen P.L.L.P.</u>					
Lockridge Grindal Nauen P.L.L.P.	Other General Gov't	June 2023 Government Relations Services	3,333.33	160777	06/15/2023 1
Total for Lockridge Grindal Nauen P.L.L.P.			3,333.33		
<u>Lombardi</u>					
Lombardi	Non-departmental	Refund Check 017866-000, 922 N Park St N Apt	0.17	160588	06/02/2023 1
Lombardi	Non-departmental	Refund Check 017866-000, 922 N Park St N Apt	0.02	160588	06/02/2023 1
Lombardi	Non-departmental	Refund Check 017866-000, 922 N Park St N Apt	0.11	160588	06/02/2023 1
Lombardi	Non-departmental	Refund Check 017866-000, 922 N Park St N Apt	0.21	160588	06/02/2023 1
Lombardi	Non-departmental	Refund Check 017866-000, 922 N Park St N Apt	0.17	160588	06/02/2023 1
Total for Lombardi			0.68		
<u>MacQueen Equipment LLC</u>					
MacQueen Equipment LLC	Storm Sewer Mnt	Street Sweeper #123 Parts	3,484.48	160751	06/15/2023 1
MacQueen Equipment LLC	Storm Sewer Mnt	Radiator	1,610.11	160507	06/01/2023 1
Total for MacQueen Equipment LLC			5,094.59		
<u>Mankato/Fairmont Fire & Safety</u>					
Mankato/Fairmont Fire & Safety	Airport	Fire Extinguisher Inspection/Service Call Airport	99.00	160831	06/21/2023 1
Total for Mankato/Fairmont Fire & Safety			99.00		
<u>Marco Technologies, LLC</u>					
Marco Technologies, LLC	Airport	Contract Base Rate 06/02 to 07/01 Usage 05/02 to 06/01/23 CH	3.66	160752	06/15/2023 1
Marco Technologies, LLC	Airport	Contract Base Rate 05/22/23 to 06/21/23	2.45	160456	05/26/2023 1
Marco Technologies, LLC	Data Processing	Contract Base Rate 04/22 to 05/21 Usage 01/22 to 04/21/23 CH	5.56	160752	06/15/2023 1
Marco Technologies, LLC	Airport	Contract Base Rate 04/22 to 05/21 Usage 01/22 to 04/21/23 CH	3.70	160752	06/15/2023 1
Marco Technologies, LLC	Airport	Contract Base Rate 06/22 to 07/21/23 City Hall	2.45	160866	06/27/2023 1

Accounts Payable
Check Approval List - City Council

From: 05/24/2023

To: 06/27/2023



<u>Vendor</u>	<u>Department</u>	<u>Description</u>	<u>Amount</u>	<u>Check Number</u>	<u>Check Date</u>
Marco Technologies, LLC	Liquor Store	Contract Base Rate 05/22/23 to 06/21/23	2.45	160456	05/26/2023 1
Marco Technologies, LLC	Liquor Store	Contract Base Rate 06/22 to 07/21/23 City Hall	2.45	160866	06/27/2023 1
Marco Technologies, LLC	Liquor Store	Contract Base Rate 04/22 to 05/21 Usage 01/22 to 04/21/23 CH	3.70	160752	06/15/2023 1
Marco Technologies, LLC	Liquor Store	Contract Base Rate 05/14 to 06/13, Usage 02/14 to 05/13/23	76.14	160752	06/15/2023 1
Marco Technologies, LLC	Liquor Store	Contract Base Rate 06/14 to 07/13/2023	26.14	160752	06/15/2023 1
Marco Technologies, LLC	Liquor Store	Contract Base Rate 06/02 to 07/01 Usage 05/02 to 06/01/23 CH	3.66	160752	06/15/2023 1
Marco Technologies, LLC	Engineering	Contract Base Rate 06/02 to 07/01 Usage 05/02 to 06/01/23 CH	27.45	160752	06/15/2023 1
Marco Technologies, LLC	Paved Streets	Contract Base Rate 04/22 to 05/21 Usage 01/22 to 04/21/23 CH	3.70	160752	06/15/2023 1
Marco Technologies, LLC	Paved Streets	Contract Base Rate 06/02 to 07/01 Usage 05/02 to 06/01/23 CH	3.66	160752	06/15/2023 1
Marco Technologies, LLC	Paved Streets	Contract Base Rate 06/22 to 07/21/23 City Hall	2.45	160866	06/27/2023 1
Marco Technologies, LLC	Paved Streets	Contract Base Rate 05/14 to 06/13, Usage 02/14 to 05/13/23	13.05	160752	06/15/2023 1
Marco Technologies, LLC	City Manager	Contract Base Rate 05/22/23 to 06/21/23	3.68	160456	05/26/2023 1
Marco Technologies, LLC	Economic Development	Contract Base Rate 06/02 to 07/01 Usage 05/02 to 06/01/23 CH	18.30	160752	06/15/2023 1
Marco Technologies, LLC	Economic Development	Contract Base Rate 04/22 to 05/21 Usage 01/22 to 04/21/23 CH	18.52	160752	06/15/2023 1
Marco Technologies, LLC	Economic Development	Contract Base Rate 06/22 to 07/21/23 City Hall	12.27	160866	06/27/2023 1
Marco Technologies, LLC	Economic Development	Contract Base Rate 05/22/23 to 06/21/23	12.27	160456	05/26/2023 1
Marco Technologies, LLC	Engineering	Contract Base Rate 06/14 to 07/13/2023	13.07	160752	06/15/2023 1
Marco Technologies, LLC	Engineering	Contract Base Rate 05/22/23 to 06/21/23	18.45	160456	05/26/2023 1
Marco Technologies, LLC	Engineering	Contract Base Rate 06/22 to 07/21/23 City Hall	18.41	160866	06/27/2023 1
Marco Technologies, LLC	Engineering	Contract Base Rate 04/22 to 05/21 Usage 01/22 to 04/21/23 CH	27.78	160752	06/15/2023 1
Marco Technologies, LLC	Engineering	Contract Base Rate 05/14 to 06/13, Usage 02/14 to 05/13/23	13.07	160752	06/15/2023 1
Marco Technologies, LLC	Building Inspection	Contract Base Rate 06/22 to 07/21/23 City Hall	6.14	160866	06/27/2023 1
Marco Technologies, LLC	Building Inspection	Contract Base Rate 06/02 to 07/01 Usage 05/02 to 06/01/23 CH	9.15	160752	06/15/2023 1
Marco Technologies, LLC	Building Inspection	Contract Base Rate 05/22/23 to 06/21/23	6.14	160456	05/26/2023 1
Marco Technologies, LLC	Data Processing	Contract Base Rate 05/22/23 to 06/21/23	3.68	160456	05/26/2023 1
Marco Technologies, LLC	Data Processing	Contract Base Rate 06/22 to 07/21/23 City Hall	3.68	160866	06/27/2023 1
Marco Technologies, LLC	Data Processing	Contract Base Rate 06/02 to 07/01 Usage 05/02 to 06/01/23 CH	5.49	160752	06/15/2023 1
Marco Technologies, LLC	Building Inspection	Contract Base Rate 04/22 to 05/21 Usage 01/22 to 04/21/23 CH	9.26	160752	06/15/2023 1
Marco Technologies, LLC	Paved Streets	Contract Base Rate 06/14 to 07/13/2023	13.05	160752	06/15/2023 1
Marco Technologies, LLC	Paved Streets	Contract Base Rate 05/22/23 to 06/21/23	2.45	160456	05/26/2023 1
Marco Technologies, LLC	Parking Lots	Contract Base Rate 05/22/23 to 06/21/23	2.45	160456	05/26/2023 1
Marco Technologies, LLC	Parking Lots	Contract Base Rate 06/02 to 07/01 Usage 05/02 to 06/01/23 CH	3.66	160752	06/15/2023 1
Marco Technologies, LLC	Parking Lots	Contract Base Rate 06/22 to 07/21/23 City Hall	2.45	160866	06/27/2023 1
Marco Technologies, LLC	Parking Lots	Contract Base Rate 04/22 to 05/21 Usage 01/22 to 04/21/23 CH	3.70	160752	06/15/2023 1
Marco Technologies, LLC	Parks	Contract Base Rate 06/22 to 07/21/23 City Hall	3.68	160866	06/27/2023 1
Marco Technologies, LLC	Parks	Contract Base Rate 06/02 to 07/01 Usage 05/02 to 06/01/23 CH	5.49	160752	06/15/2023 1
Marco Technologies, LLC	Crime Control & Investigation	Contract Base Rate 06/22 to 07/21/23 City Hall	2.45	160866	06/27/2023 1
Marco Technologies, LLC	Crime Control & Investigation	Contract Base Rate 04/22 to 05/21 Usage 01/22 to 04/21/23 CH	3.70	160752	06/15/2023 1
Marco Technologies, LLC	Crime Control & Investigation	Contract Base Rate 06/02 to 07/01 Usage 05/02 to 06/01/23 CH	3.66	160752	06/15/2023 1
Marco Technologies, LLC	Crime Control & Investigation	Contract Base Rate 05/22/23 to 06/21/23	2.45	160456	05/26/2023 1
Marco Technologies, LLC	Recording & Reporting	Contract Base Rate 06/14 to 07/13/2023	13.07	160752	06/15/2023 1
Marco Technologies, LLC	Recording & Reporting	Contract Base Rate 04/22 to 05/21 Usage 01/22 to 04/21/23 CH	5.56	160752	06/15/2023 1
Marco Technologies, LLC	Recording & Reporting	Contract Base Rate 06/22 to 07/21/23 City Hall	3.68	160866	06/27/2023 1

Accounts Payable
Check Approval List - City Council



From: 05/24/2023

To: 06/27/2023

<u>Vendor</u>	<u>Department</u>	<u>Description</u>	<u>Amount</u>	<u>Check Number</u>	<u>Check Date</u>
Marco Technologies, LLC	Recording & Reporting	Contract Base Rate 05/22/23 to 06/21/23	3.68	160456	05/26/2023 1
Marco Technologies, LLC	Recording & Reporting	Contract Base Rate 05/14 to 06/13, Usage 02/14 to 05/13/23	13.07	160752	06/15/2023 1
Marco Technologies, LLC	Recording & Reporting	Contract Base Rate 06/02 to 07/01 Usage 05/02 to 06/01/23 CH	5.49	160752	06/15/2023 1
Marco Technologies, LLC	Lake Restoration	Contract Base Rate 06/22 to 07/21/23 City Hall	2.45	160866	06/27/2023 1
Marco Technologies, LLC	Lake Restoration	Contract Base Rate 05/22/23 to 06/21/23	2.45	160456	05/26/2023 1
Marco Technologies, LLC	Lake Restoration	Contract Base Rate 04/22 to 05/21 Usage 01/22 to 04/21/23 CH	3.70	160752	06/15/2023 1
Marco Technologies, LLC	Lake Restoration	Contract Base Rate 06/02 to 07/01 Usage 05/02 to 06/01/23 CH	3.66	160752	06/15/2023 1
Marco Technologies, LLC	Director of Finance	Contract Base Rate 05/22/23 to 06/21/23	3.68	160456	05/26/2023 1
Marco Technologies, LLC	Director of Finance	Contract Base Rate 06/22 to 07/21/23 City Hall	3.68	160866	06/27/2023 1
Marco Technologies, LLC	Director of Finance	Contract Base Rate 05/14 to 06/13, Usage 02/14 to 05/13/23	51.31	160752	06/15/2023 1
Marco Technologies, LLC	Director of Finance	Contract Base Rate 06/02 to 07/01 Usage 05/02 to 06/01/23 CH	5.49	160752	06/15/2023 1
Marco Technologies, LLC	Director of Finance	Contract Base Rate 06/14 to 07/13/2023	39.21	160752	06/15/2023 1
Marco Technologies, LLC	Director of Finance	Contract Base Rate 04/22 to 05/21 Usage 01/22 to 04/21/23 CH	5.56	160752	06/15/2023 1
Marco Technologies, LLC	Fire Fighting	Contract Base Rate 06/02 to 07/01 Usage 05/02 to 06/01/23 CH	5.49	160752	06/15/2023 1
Marco Technologies, LLC	Fire Fighting	Contract Base Rate 06/22 to 07/21/23 City Hall	3.68	160866	06/27/2023 1
Marco Technologies, LLC	Fire Fighting	Contract Base Rate 04/22 to 05/21 Usage 01/22 to 04/21/23 CH	5.56	160752	06/15/2023 1
Marco Technologies, LLC	Fire Fighting	Contract Base Rate 05/22/23 to 06/21/23	3.68	160456	05/26/2023 1
Marco Technologies, LLC	City Manager	Contract Base Rate 06/14 to 07/13/2023	13.07	160752	06/15/2023 1
Marco Technologies, LLC	City Manager	Contract Base Rate 04/22 to 05/21 Usage 01/22 to 04/21/23 CH	5.56	160752	06/15/2023 1
Marco Technologies, LLC	City Manager	Contract Base Rate 06/22 to 07/21/23 City Hall	3.68	160866	06/27/2023 1
Marco Technologies, LLC	City Manager	Contract Base Rate 05/14 to 06/13, Usage 02/14 to 05/13/23	13.07	160752	06/15/2023 1
Marco Technologies, LLC	City Manager	Contract Base Rate 06/02 to 07/01 Usage 05/02 to 06/01/23 CH	5.49	160752	06/15/2023 1
Marco Technologies, LLC	Planning & Zoning	Contract Base Rate 06/14 to 07/13/2023	13.05	160752	06/15/2023 1
Marco Technologies, LLC	Planning & Zoning	Contract Base Rate 05/22/23 to 06/21/23	6.14	160456	05/26/2023 1
Marco Technologies, LLC	Planning & Zoning	Contract Base Rate 04/22 to 05/21 Usage 01/22 to 04/21/23 CH	9.26	160752	06/15/2023 1
Marco Technologies, LLC	Planning & Zoning	Contract Base Rate 06/22 to 07/21/23 City Hall	6.14	160866	06/27/2023 1
Marco Technologies, LLC	Planning & Zoning	Contract Base Rate 06/02 to 07/01 Usage 05/02 to 06/01/23 CH	9.15	160752	06/15/2023 1
Marco Technologies, LLC	Police Administration	Contract Base Rate 06/22 to 07/21/23 City Hall	2.45	160866	06/27/2023 1
Marco Technologies, LLC	Planning & Zoning	Contract Base Rate 05/14 to 06/13, Usage 02/14 to 05/13/23	13.05	160752	06/15/2023 1
Marco Technologies, LLC	Police Administration	Contract Base Rate 05/22/23 to 06/21/23	2.45	160456	05/26/2023 1
Marco Technologies, LLC	Police Administration	Contract Base Rate 04/22 to 05/21 Usage 01/22 to 04/21/23 CH	3.70	160752	06/15/2023 1
Marco Technologies, LLC	Police Administration	Contract Base Rate 06/02 to 07/01 Usage 05/02 to 06/01/23 CH	3.66	160752	06/15/2023 1
Marco Technologies, LLC	Parks	Contract Base Rate 05/22/23 to 06/21/23	3.68	160456	05/26/2023 1
Marco Technologies, LLC	Parks	Contract Base Rate 04/22 to 05/21 Usage 01/22 to 04/21/23 CH	5.56	160752	06/15/2023 1
Total for Marco Technologies, LLC			734.53		
<u>Martin County Attorney's</u>					
Martin County Attorney's	Other General Gov't	May 2023 Prosecutorial Services	6,250.00	160641	06/09/2023 1
Martin County Attorney's	Public Safety Charges	Forfeiture Funds FMP22-2683	39.00	160867	06/27/2023 1
Martin County Attorney's	Public Safety Charges	Forfeiture Funds FMP21-1922	57.00	160867	06/27/2023 1
Total for Martin County Attorney's			6,346.00		
<u>Martin County Auditor</u>					
Martin County Auditor	Crime Control & Investigation	Feb 2023 Frontier Phone Bill Police Dept	301.23	160642	06/09/2023 1
Martin County Auditor	Crime Control & Investigation	May 2023 Frontier Phone Bill Police Dept	332.67	160642	06/09/2023 1

Accounts Payable
Check Approval List - City Council

From: 05/24/2023

To: 06/27/2023



<u>Vendor</u>	<u>Department</u>	<u>Description</u>	<u>Amount</u>	<u>Check Number</u>	<u>Check Date</u>
Martin County Auditor	Crime Control & Investigation	April 2023 Frontier Phone Bill Police Dept	332.67	160642	06/09/2023 1
Martin County Auditor	Crime Control & Investigation	June 2023 Rental of Security Building	4,776.59	160557	06/02/2023 1
Total for Martin County Auditor			5,743.16		
<u>Martin County Highway Dept</u>					
Martin County Highway Dept	Crime Control & Investigation	motor fuel usage-may	2,946.39	160687	06/09/2023 1
Martin County Highway Dept	Other General Gov't	motor fuel usage-may	141.18	160687	06/09/2023 1
Martin County Highway Dept	Fire Fighting	motor fuel usage-may	720.33	160687	06/09/2023 1
Martin County Highway Dept	Parks	motor fuel usage-may	2,975.64	160687	06/09/2023 1
Martin County Highway Dept	Airport	motor fuel usage-may	130.54	160687	06/09/2023 1
Martin County Highway Dept	Paved Streets	motor fuel usage-may	2,141.50	160687	06/09/2023 1
Martin County Highway Dept	Engineering	motor fuel usage-may	41.57	160687	06/09/2023 1
Martin County Highway Dept	Garbage Collection	motor fuel usage-may	287.81	160687	06/09/2023 1
Martin County Highway Dept	Storm Sewer Mnt	motor fuel usage-may	659.66	160687	06/09/2023 1
Martin County Highway Dept	Animal Control	motor fuel usage-may	95.31	160687	06/09/2023 1
Total for Martin County Highway Dept			10,139.93		
<u>Martin County Recorder</u>					
Martin County Recorder	Urban Redevelopment & Housing	Satisfaction of Mortgage Old Northrop Bar/Montana Thiesse	46.00	160558	06/02/2023 1
Total for Martin County Recorder			46.00		
<u>Martin County Star Inc.</u>					
Martin County Star Inc.	Aquatic Park	Summer Events Ad Aquatic Park	285.00	160643	06/09/2023 1
Total for Martin County Star Inc.			285.00		
<u>Martin-Mcallister Consulting Psycholo</u>					
Martin-Mcallister Consulting Psychologists, Inc.	Crime Control & Investigation	Public Safety Assessments	1,875.00	160644	06/09/2023 1
Total for Martin-Mcallister Consulting Psycholo			1,875.00		
<u>MCSAP Coalition</u>					
MCSAP Coalition	Liquor Store	Youth Connection Sponsorship May 2023	275.00	160612	06/08/2023 1
Total for MCSAP Coalition			275.00		
<u>Medsurety LLC</u>					
Medsurety LLC	Health Insurance	COBRA Continuation Admin Fees, Retiree Billing	90.25	0	06/12/2023 1
Total for Medsurety LLC			90.25		
<u>Metro Sales Inc.</u>					
Metro Sales Inc.	Paved Streets	Contract Base Rate 06/03 to 09/02/23 & Usage 03/03 to 06/02 PW	50.47	160753	06/15/2023 1
Metro Sales Inc.	Crime Control & Investigation	Contract Base Rate 06/03 to 09/02/23 & Usage 03/03 to 06/02/23PD	479.34	160753	06/15/2023 1
Metro Sales Inc.	Parks	Contract Base Rate 06/03 to 09/02/23 & Usage 03/03 to 06/02 PW	50.48	160753	06/15/2023 1
Total for Metro Sales Inc.			580.29		
<u>MHSRC/Range</u>					
MHSRC/Range	Crime Control & Investigation	PIT Hybrid Training 05/24/2023 Stevens	635.00	160559	06/02/2023 1
MHSRC/Range	Crime Control & Investigation	PIT Hybrid 05/09/23 Schwebke	635.00	160457	05/26/2023 1
MHSRC/Range	Crime Control & Investigation	EVOC/PIT Refresher Hybrid 05/25/2023 Stevens	490.00	160559	06/02/2023 1
MHSRC/Range	Crime Control & Investigation	EVOC/PIT Refresher Hybrid 05/10/23 Schwebke	490.00	160457	05/26/2023 1
Total for MHSRC/Range			2,250.00		
<u>Midco</u>					
Midco	Crime Control & Investigation	June 2023 Telephone City Hall	29.65	160754	06/15/2023 1

Accounts Payable
Check Approval List - City Council



From: 05/24/2023

To: 06/27/2023

<u>Vendor</u>	<u>Department</u>	<u>Description</u>	<u>Amount</u>	<u>Check Number</u>	<u>Check Date</u>
Midco	Recording & Reporting	June 2023 Telephone City Hall	59.30	160754	06/15/2023 1
Midco	SMEC Building	June 2023 Telephone SMEC	122.10	160754	06/15/2023 1
Midco	Aquatic Park	June 2023 Telephone Aquatic Park	63.24	160754	06/15/2023 1
Midco	Parks	June 2023 Telephone City Hall	29.65	160754	06/15/2023 1
Midco	Parks	June 2023 Telephone 801 E Margaret St Public Works	169.28	160754	06/15/2023 1
Midco	Parks	June 2023 Telephone 401 E Margaret St	38.14	160754	06/15/2023 1
Midco	Planning & Zoning	June 2023 Telephone City Hall	49.42	160754	06/15/2023 1
Midco	Director of Finance	June 2023 Telephone City Hall	49.42	160754	06/15/2023 1
Midco	Fire Fighting	June 2023 Telephone City Hall	19.77	160754	06/15/2023 1
Midco	Fire Fighting	June 2023 Telephone Fire Dept	59.30	160754	06/15/2023 1
Midco	Central Garage	June 2023 Telephone City Hall	19.77	160754	06/15/2023 1
Midco	City Manager	June 2023 Telephone City Hall	128.49	160754	06/15/2023 1
Midco	Paved Streets	June 2023 Telephone 401 E Margaret St	38.14	160754	06/15/2023 1
Midco	Data Processing	June 2023 City Hall Internet Circuit	600.39	160754	06/15/2023 1
Midco	Building Inspection	June 2023 Telephone City Hall	49.42	160754	06/15/2023 1
Midco	Paved Streets	June 2023 Telephone 801 E Margaret St Public Works	169.27	160754	06/15/2023 1
Midco	Paved Streets	June 2023 Telephone City Hall	59.30	160754	06/15/2023 1
Midco	Economic Development	June 2023 Telephone City Hall	39.54	160754	06/15/2023 1
Midco	Engineering	June 2023 Telephone City Hall	128.49	160754	06/15/2023 1
Midco	Library	June 2023 Telephone Library	521.01	160754	06/15/2023 1
Midco	Liquor Store	June 2023 Telephone Liquor Store	201.54	160754	06/15/2023 1
Midco	Airport	June 2023 Airport Ethernet Circuit	307.39	160754	06/15/2023 1
Midco	Airport	June 2023 Telephone City Hall	29.65	160754	06/15/2023 1
Midco	Airport	June 2023 Telephone Airport	60.74	160754	06/15/2023 1
		Total for Midco	3,042.41		
<u>Midwest Garage Doors of Fairmont, Inc</u>					
Midwest Garage Doors of Fairmont, Inc.	Paved Streets	Repaired Door on City Shop	31.25	160832	06/21/2023 1
Midwest Garage Doors of Fairmont, Inc.	Parks	Repaired Door on City Shop	31.25	160832	06/21/2023 1
		Total for Midwest Garage Doors of Fairmont, Inc	62.50		
<u>Mike's Emergency Vehicle Installation,</u>					
Mike's Emergency Vehicle Installation, LLC	Crime Control & Investigation	Install new docking station in squad #10, Install new radarUnit1	227.66	160458	05/26/2023 1
		Total for Mike's Emergency Vehicle Installation,	227.66		
<u>Miller</u>					
Miller	Fire Fighting	Ship Fire Pagers for Repair	10.30	160833	06/21/2023 1
		Total for Miller	10.30		
<u>Miller Sellner</u>					
Miller Sellner	Parks	Dipstick Park#547	58.50	160508	06/01/2023 1
Miller Sellner	Parks	HVAC Control Park #547	255.00	160482	05/30/2023 1
		Total for Miller Sellner	313.50		
<u>Minnesota Elevator, Inc</u>					
Minnesota Elevator, Inc	SMEC Building	Jun-Aug Quarterly Elevator Service SMEC	512.86	160560	06/02/2023 1
Minnesota Elevator, Inc	Library	Jun-Jul 2023 Bi-Monthly Elevator Service Library	177.98	160560	06/02/2023 1
		Total for Minnesota Elevator, Inc	690.84		

Accounts Payable
Check Approval List - City Council



From: 05/24/2023

To: 06/27/2023

<u>Vendor</u>	<u>Department</u>	<u>Description</u>	<u>Amount</u>	<u>Check Number</u>	<u>Check Date</u>
<u>Mn Chiefs of Police Association</u>					
Mn Chiefs of Police Association	Crime Control & Investigation	CLEO Training Feb 2024	795.00	160834	06/21/2023 1
		Total for Mn Chiefs of Police Association	795.00		
<u>MN Dept Labor & Indust.</u>					
MN Dept Labor & Indust.	Parks	260 Lair Rd W Gomsrud Park Replace Water Heater & Relocate	36.00	160561	06/02/2023 1
MN Dept Labor & Indust.	Parks	Electrical Inspection Power Washer Circuit/Recpt 801 E Margaret	18.00	160483	05/30/2023 1
MN Dept Labor & Indust.	Paved Streets	Electrical Inspection Power Washer Circuit/Recpt 801 E Margaret	18.00	160483	05/30/2023 1
		Total for MN Dept Labor & Indust.	72.00		
<u>Mn Dept of Employment & Economic D</u>					
Mn Dept of Employment & Economic Developmen	Intergovernmental Revenues	July 2023 MN Investment Fund Grant City of Fmt/Zierke Built Mfg	4,597.00	160755	06/15/2023 1
Mn Dept of Employment & Economic Developmen	Intergovernmental Revenues	July 2023 Loan #2 City of Fmt/Zierke Built Mfg	3,064.18	160755	06/15/2023 1
		Total for Mn Dept of Employment & Economic D	7,661.18		
<u>MN Energy Resources Corp.</u>					
MN Energy Resources Corp.	Central Garage	gas utilities-417 e margaret	31.71	160432	05/25/2023 1
MN Energy Resources Corp.	Fire Fighting	Gas Utilities 05/03 to 06/04/2023 Fire Station	180.73	160756	06/15/2023 1
MN Energy Resources Corp.	Central Garage	Gas Utilities 05/15 to 06/14/2023 417 E Margaret St	9.91	160868	06/27/2023 1
MN Energy Resources Corp.	Central Garage	gas utilities-801 E Margaret	215.30	160432	05/25/2023 1
MN Energy Resources Corp.	Parks	Gas utilities 05/08 to 06/08/2023 Lincoln Shelter House	43.25	160756	06/15/2023 1
MN Energy Resources Corp.	Parks	gas utilities-417 e margaret	97.39	160432	05/25/2023 1
MN Energy Resources Corp.	Parks	gas utilities-801 E Margaret	661.32	160432	05/25/2023 1
MN Energy Resources Corp.	Aquatic Park	gas utilities-aquatic park	118.67	160432	05/25/2023 1
MN Energy Resources Corp.	Parks	Gas Utilities 05/15 to 06/14/2023 417 E Margaret St	30.50	160868	06/27/2023 1
MN Energy Resources Corp.	Paved Streets	gas utilities-417 e margaret	97.39	160432	05/25/2023 1
MN Energy Resources Corp.	Paved Streets	Gas Utilities 05/15 to 06/14/2023 417 E Margaret St	30.50	160868	06/27/2023 1
MN Energy Resources Corp.	Paved Streets	gas utilities-801 E Margaret	661.32	160432	05/25/2023 1
MN Energy Resources Corp.	Library	Gas Utilities 04/21 to 05/22/2023 Library	2,037.66	160509	06/01/2023 1
MN Energy Resources Corp.	Liquor Store	gas utilities-liquor store	239.42	160432	05/25/2023 1
MN Energy Resources Corp.	Liquor Store	Gas Utilities 05/15 to 06/14/2023 Liquor Store	62.27	160868	06/27/2023 1
MN Energy Resources Corp.	Incubator Building	Gas Utilities 05/15 to 06/14/2023 Incubator	93.80	160868	06/27/2023 1
MN Energy Resources Corp.	Incubator Building	gas utilities-429 Winnebago	349.28	160432	05/25/2023 1
MN Energy Resources Corp.	Animal Control	gas utilities-522 e margaret	117.77	160432	05/25/2023 1
MN Energy Resources Corp.	Animal Control	Gas Utilities 05/15 to 06/14/2023 Humane Society	26.41	160868	06/27/2023 1
		Total for MN Energy Resources Corp.	5,104.60		
<u>Monsen, Patricia</u>					
Monsen, Patricia	Local Access	City Clerk Conference 05/14 to 05/18/2023 Minneapolis, MN	326.13	0	05/30/2023 1
		Total for Monsen, Patricia	326.13		
<u>M-R Sign Company</u>					
M-R Sign Company	Paved Streets	Snowmobile Crossing Sign Repair	195.46	160836	06/21/2023 1
		Total for M-R Sign Company	195.46		
<u>Municipal Emergency Services Deposi</u>					
Municipal Emergency Services Depository Accoun	Fire Fighting	Boots Fire Dept	449.71	160459	05/26/2023 1
Municipal Emergency Services Depository Accoun	Fire Fighting	Turn Out Gear	6,372.00	160758	06/15/2023 1
		Total for Municipal Emergency Services Depositi	6,821.71		

Accounts Payable
Check Approval List - City Council

From: 05/24/2023

To: 06/27/2023



<u>Vendor</u>	<u>Department</u>	<u>Description</u>	<u>Amount</u>	<u>Check Number</u>	<u>Check Date</u>
<u>Napa Auto Fairmont</u>					
Napa Auto Fairmont	Central Garage	14g Wire City Shop	98.00	160510	06/01/2023 1
Napa Auto Fairmont	Parks	Filter #534	5.04	160510	06/01/2023 1
Napa Auto Fairmont	Parks	Oil Filter, Air Outer & Inner Filter Park #538	30.08	160837	06/21/2023 1
Napa Auto Fairmont	Parks	Oil Filter Park #503	3.37	160759	06/15/2023 1
Napa Auto Fairmont	Parks	Oil Filter Park #542	3.37	160484	05/30/2023 1
Napa Auto Fairmont	Parks	Air Filter Craftsman Tiller Park Dept	5.06	160484	05/30/2023 1
Napa Auto Fairmont	Parks	Engine Oil, Trans Hyd Filter #534	3.37	160510	06/01/2023 1
Napa Auto Fairmont	Parks	Oil Filter Park 519	3.37	160759	06/15/2023 1
Napa Auto Fairmont	Crime Control & Investigation	Oil Filter Police #8	3.37	160759	06/15/2023 1
Napa Auto Fairmont	Crime Control & Investigation	Oil Filter Police #11	3.37	160837	06/21/2023 1
Napa Auto Fairmont	Road & Bridge Equipment	Oil, Fuel & Air Filters Street #113	83.87	160510	06/01/2023 1
Napa Auto Fairmont	Road & Bridge Equipment	Oil & Fuel Filter Street #106	36.85	160759	06/15/2023 1
Napa Auto Fairmont	Storm Sewer Mnt	Oil Filter #123X	7.57	160759	06/15/2023 1
		Total for Napa Auto Fairmont	286.69		
<u>Nelson</u>					
Nelson	Crime Control & Investigation	ERU Training Worthington, MN 05/17/2023	15.00	0	06/09/2023 1
Nelson	Aquatic Park Charges	Refund 3 sessions of swimming lessons	130.00	160760	06/15/2023 1
		Total for Nelson	145.00		
<u>Neo Electrical Solutions, LLC</u>					
Neo Electrical Solutions, LLC	Airport	Semi Annual MALSRS FQJ 31 Airport WO#5091	2,285.00	160460	05/26/2023 1
		Total for Neo Electrical Solutions, LLC	2,285.00		
<u>Neusch</u>					
Neusch	Engineering	05/16 to 05/17/23 Wetland Certificate Training Rochester, MN	357.50	160485	05/30/2023 1
		Total for Neusch	357.50		
<u>Nutrien Ag Solutions, Inc</u>					
Nutrien Ag Solutions, Inc	Parks	Triplet & Bark Oil	1,642.42	160511	06/01/2023 1
		Total for Nutrien Ag Solutions, Inc	1,642.42		
<u>Olabarrieta</u>					
Olabarrieta	Non-departmental	Refund Check 018607-000, 1020 N Main St	0.95	160589	06/02/2023 1
Olabarrieta	Non-departmental	Refund Check 018607-000, 1020 N Main St	0.36	160589	06/02/2023 1
Olabarrieta	Non-departmental	Refund Check 018607-000, 1020 N Main St	0.25	160589	06/02/2023 1
Olabarrieta	Non-departmental	Refund Check 018607-000, 1020 N Main St	0.36	160589	06/02/2023 1
Olabarrieta	Non-departmental	Refund Check 018607-000, 1020 N Main St	0.04	160589	06/02/2023 1
		Total for Olabarrieta	1.96		
<u>Old Northrop Bar</u>					
Old Northrop Bar	Non-departmental	Refund Loan Payment	416.67	160562	06/02/2023 1
		Total for Old Northrop Bar	416.67		
<u>Olson</u>					
Olson	Parks	Safety Toe Boot Reimbursement	127.49	160761	06/15/2023 1
		Total for Olson	127.49		
<u>Olson Rentals, Inc.</u>					
Olson Rentals, Inc.	Parks	Bands, Peds & Straps for Leaf Blowers	400.80	160512	06/01/2023 1

**Accounts Payable
Check Approval List - City Council**

From: 05/24/2023

To: 06/27/2023



<u>Vendor</u>	<u>Department</u>	<u>Description</u>	<u>Amount</u>	<u>Check Number</u>	<u>Check Date</u>
Total for Olson Rentals, Inc.			400.80		
<u>Optum</u>					
Optum	Health Insurance	June 2023 Employee Assistance Program Premiums	159.21	0	06/15/2023 1
Total for Optum			159.21		
<u>Oquawka Boats & Fabrication Inc</u>					
Oquawka Boats & Fabrication Inc	Fire Fighting	Burgandy Boat Seat Cushion	305.00	160646	06/09/2023 1
Total for Oquawka Boats & Fabrication Inc			305.00		
<u>O'Reilly Auto Parts</u>					
O'Reilly Auto Parts	Central Garage	A/C Thermometers City Shop	36.28	160762	06/15/2023 1
O'Reilly Auto Parts	Central Garage	Distributor Wrenches, Grease Needle	27.97	160762	06/15/2023 1
O'Reilly Auto Parts	Parks	Distributor Park # 503	136.16	160762	06/15/2023 1
O'Reilly Auto Parts	Parks	Trailer Hitch Park 519	119.99	160762	06/15/2023 1
O'Reilly Auto Parts	Parks	Battery Park 519	108.71	160762	06/15/2023 1
O'Reilly Auto Parts	Parks	Belt, Tensioner #502 Park	94.67	160838	06/21/2023 1
O'Reilly Auto Parts	Ice & Snow Removal	Lock Rod Clip Set Street #134	3.73	160513	06/01/2023 1
O'Reilly Auto Parts	Road & Bridge Equipment	Distributor Street #141	136.16	160838	06/21/2023 1
O'Reilly Auto Parts	Road & Bridge Equipment	Tailgate Clip #134	3.73	160762	06/15/2023 1
Total for O'Reilly Auto Parts			667.40		
<u>Paper Roll Products LLC</u>					
Paper Roll Products LLC	Liquor Store	Thermal Receipt Paper Liquor Store	164.82	160613	06/08/2023 1
Total for Paper Roll Products LLC			164.82		
<u>Paustis Wine Company</u>					
Paustis Wine Company	Liquor - Mdse for Resale	Freight	15.00	160852	06/21/2023 1
Paustis Wine Company	Liquor - Mdse for Resale	Liquor	87.00	160852	06/21/2023 1
Paustis Wine Company	Liquor - Mdse for Resale	Freight	27.00	160614	06/08/2023 1
Paustis Wine Company	Liquor - Mdse for Resale	Wine	1,052.80	160852	06/21/2023 1
Paustis Wine Company	Liquor - Mdse for Resale	Wine	1,948.00	160614	06/08/2023 1
Paustis Wine Company	Liquor - Mdse for Resale	Wine	912.00	160852	06/21/2023 1
Paustis Wine Company	Liquor - Mdse for Resale	Freight	19.50	160852	06/21/2023 1
Total for Paustis Wine Company			4,061.30		
<u>PC Janitorial Supply</u>					
PC Janitorial Supply	SMEC Building	Cleaning Supplies SMEC	358.75	160461	05/26/2023 1
PC Janitorial Supply	Aquatic Park	Cleaning Supplies Aquatic Park	72.95	160839	06/21/2023 1
PC Janitorial Supply	Parks	Cleaning Supplies Park Dept	127.10	160647	06/09/2023 1
PC Janitorial Supply	Aquatic Park	Aquatic Park Cleaning Supplies	647.22	160486	05/30/2023 1
PC Janitorial Supply	Aquatic Park	Cleaning Supplies Park Dept	456.80	160853	06/21/2023 1
PC Janitorial Supply	Aquatic Park	Paper Roll Towels Dispenser Aquatic Park	82.95	160647	06/09/2023 1
PC Janitorial Supply	Aquatic Park	Cleaning Supplies Aquatic Park	557.55	160461	05/26/2023 1
PC Janitorial Supply	Parks	Cleaning Supplies Park Dept	2,297.50	160839	06/21/2023 1
PC Janitorial Supply	Parks	Cleaning Supplies Park Dept	164.15	160763	06/15/2023 1
PC Janitorial Supply	Parks	Cleaning Supplies Park Dept	207.65	160763	06/15/2023 1
PC Janitorial Supply	Parks	Cleaning Supplies Park Dept	105.10	160763	06/15/2023 1
PC Janitorial Supply	Fire Fighting	Cleaning Supplies Fire Dept	99.00	160839	06/21/2023 1

Accounts Payable
Check Approval List - City Council

From: 05/24/2023

To: 06/27/2023



<u>Vendor</u>	<u>Department</u>	<u>Description</u>	<u>Amount</u>	<u>Check Number</u>	<u>Check Date</u>
PC Janitorial Supply	General Government Buildings	City Hall Cleaning Supplies	103.90	160461	05/26/2023 1
		Total for PC Janitorial Supply	5,280.62		
<u>Phillips Wine & Spirits</u>					
Phillips Wine & Spirits	Liquor - Mdse for Resale	Beer	1,891.86	160854	06/21/2023 1
Phillips Wine & Spirits	Liquor - Mdse for Resale	Freight	76.24	160615	06/08/2023 1
Phillips Wine & Spirits	Liquor - Mdse for Resale	Freight	615.97	160854	06/21/2023 1
Phillips Wine & Spirits	Liquor - Mdse for Resale	Wine	2,243.71	160615	06/08/2023 1
Phillips Wine & Spirits	Liquor - Mdse for Resale	Freight	47.52	160615	06/08/2023 1
Phillips Wine & Spirits	Liquor - Mdse for Resale	Wine	1,830.00	160615	06/08/2023 1
Phillips Wine & Spirits	Liquor - Mdse for Resale	Freight	59.40	160615	06/08/2023 1
Phillips Wine & Spirits	Liquor - Mdse for Resale	Beer	95.40	160615	06/08/2023 1
Phillips Wine & Spirits	Liquor - Mdse for Resale	Liquor	200.00	160615	06/08/2023 1
Phillips Wine & Spirits	Liquor - Mdse for Resale	Pop/Mix	50.95	160615	06/08/2023 1
Phillips Wine & Spirits	Liquor - Mdse for Resale	Freight	1.98	160615	06/08/2023 1
Phillips Wine & Spirits	Liquor - Mdse for Resale	Beer	449.50	160615	06/08/2023 1
Phillips Wine & Spirits	Liquor - Mdse for Resale	Liquor	8,273.15	160615	06/08/2023 1
Phillips Wine & Spirits	Liquor - Mdse for Resale	Liquor	3,451.60	160615	06/08/2023 1
Phillips Wine & Spirits	Liquor - Mdse for Resale	Liquor	22,894.42	160854	06/21/2023 1
Phillips Wine & Spirits	Liquor - Mdse for Resale	Pop/Mix	713.05	160854	06/21/2023 1
Phillips Wine & Spirits	Liquor - Mdse for Resale	Freight	175.40	160615	06/08/2023 1
Phillips Wine & Spirits	Liquor - Mdse for Resale	Wine	3,190.69	160854	06/21/2023 1
		Total for Phillips Wine & Spirits	46,260.84		
<u>Pitney Bowes</u>					
Pitney Bowes	Liquor Store	Postage Machine Ink & Tape Strips	5.98	160840	06/21/2023 1
Pitney Bowes	Airport	Postage Machine Ink & Tape Strips	9.96	160840	06/21/2023 1
Pitney Bowes	Economic Development	Postage Machine Ink & Tape Strips	9.96	160840	06/21/2023 1
Pitney Bowes	Paved Streets	Postage Machine Ink & Tape Strips	3.98	160840	06/21/2023 1
Pitney Bowes	Engineering	Postage Machine Ink & Tape Strips	21.91	160840	06/21/2023 1
Pitney Bowes	Building Inspection	Postage Machine Ink & Tape Strips	9.96	160840	06/21/2023 1
Pitney Bowes	Data Processing	Postage Machine Ink & Tape Strips	5.98	160840	06/21/2023 1
Pitney Bowes	Parking Lots	Postage Machine Ink & Tape Strips	5.98	160840	06/21/2023 1
Pitney Bowes	Fire Fighting	Postage Machine Ink & Tape Strips	7.97	160840	06/21/2023 1
Pitney Bowes	City Manager	Postage Machine Ink & Tape Strips	9.96	160840	06/21/2023 1
Pitney Bowes	Parks	Postage Machine Ink & Tape Strips	7.97	160840	06/21/2023 1
Pitney Bowes	Police Administration	Postage Machine Ink & Tape Strips	3.98	160840	06/21/2023 1
Pitney Bowes	Planning & Zoning	Postage Machine Ink & Tape Strips	9.96	160840	06/21/2023 1
Pitney Bowes	Director of Finance	Postage Machine Ink & Tape Strips	9.96	160840	06/21/2023 1
Pitney Bowes	Lake Restoration	Postage Machine Ink & Tape Strips	5.98	160840	06/21/2023 1
Pitney Bowes	Recording & Reporting	Postage Machine Ink & Tape Strips	9.96	160840	06/21/2023 1
Pitney Bowes	Crime Control & Investigation	Postage Machine Ink & Tape Strips	5.98	160840	06/21/2023 1
		Total for Pitney Bowes	145.43		
<u>Pitney Bowes Bank Inc Purchase Power</u>					
Pitney Bowes Bank Inc Purchase Power	Crime Control & Investigation	Prepaid Postage	60.00	160563	06/02/2023 1

Accounts Payable
Check Approval List - City Council

From: 05/24/2023

To: 06/27/2023



<u>Vendor</u>	<u>Department</u>	<u>Description</u>	<u>Amount</u>	<u>Check Number</u>	<u>Check Date</u>
Pitney Bowes Bank Inc Purchase Power	Crime Control & Investigation	Acct# 8000-9090-1129-9471 Postage Purchased	75.60	160563	06/02/2023 1
Pitney Bowes Bank Inc Purchase Power	Recording & Reporting	Acct# 8000-9090-1129-9471 Postage Purchased	126.00	160563	06/02/2023 1
Pitney Bowes Bank Inc Purchase Power	Recording & Reporting	Prepaid Postage	100.00	160563	06/02/2023 1
Pitney Bowes Bank Inc Purchase Power	Lake Restoration	Acct# 8000-9090-1129-9471 Postage Purchased	75.60	160563	06/02/2023 1
Pitney Bowes Bank Inc Purchase Power	Lake Restoration	Prepaid Postage	60.00	160563	06/02/2023 1
Pitney Bowes Bank Inc Purchase Power	Director of Finance	Prepaid Postage	100.00	160563	06/02/2023 1
Pitney Bowes Bank Inc Purchase Power	Director of Finance	Acct# 8000-9090-1129-9471 Postage Purchased	126.00	160563	06/02/2023 1
Pitney Bowes Bank Inc Purchase Power	Police Administration	Prepaid Postage	40.00	160563	06/02/2023 1
Pitney Bowes Bank Inc Purchase Power	Police Administration	Acct# 8000-9090-1129-9471 Postage Purchased	50.40	160563	06/02/2023 1
Pitney Bowes Bank Inc Purchase Power	Planning & Zoning	Acct# 8000-9090-1129-9471 Postage Purchased	126.00	160563	06/02/2023 1
Pitney Bowes Bank Inc Purchase Power	Planning & Zoning	Prepaid Postage	100.00	160563	06/02/2023 1
Pitney Bowes Bank Inc Purchase Power	Parks	Acct# 8000-9090-1129-9471 Postage Purchased	100.80	160563	06/02/2023 1
Pitney Bowes Bank Inc Purchase Power	Parks	Prepaid Postage	80.00	160563	06/02/2023 1
Pitney Bowes Bank Inc Purchase Power	City Manager	Acct# 8000-9090-1129-9471 Postage Purchased	126.00	160563	06/02/2023 1
Pitney Bowes Bank Inc Purchase Power	City Manager	Prepaid Postage	100.00	160563	06/02/2023 1
Pitney Bowes Bank Inc Purchase Power	Fire Fighting	Prepaid Postage	80.00	160563	06/02/2023 1
Pitney Bowes Bank Inc Purchase Power	Fire Fighting	Acct# 8000-9090-1129-9471 Postage Purchased	100.80	160563	06/02/2023 1
Pitney Bowes Bank Inc Purchase Power	Parking Lots	Acct# 8000-9090-1129-9471 Postage Purchased	75.60	160563	06/02/2023 1
Pitney Bowes Bank Inc Purchase Power	Parking Lots	Prepaid Postage	60.00	160563	06/02/2023 1
Pitney Bowes Bank Inc Purchase Power	Building Inspection	Prepaid Postage	100.00	160563	06/02/2023 1
Pitney Bowes Bank Inc Purchase Power	Data Processing	Prepaid Postage	60.00	160563	06/02/2023 1
Pitney Bowes Bank Inc Purchase Power	Data Processing	Acct# 8000-9090-1129-9471 Postage Purchased	75.60	160563	06/02/2023 1
Pitney Bowes Bank Inc Purchase Power	Building Inspection	Acct# 8000-9090-1129-9471 Postage Purchased	126.00	160563	06/02/2023 1
Pitney Bowes Bank Inc Purchase Power	Paved Streets	Acct# 8000-9090-1129-9471 Postage Purchased	50.40	160563	06/02/2023 1
Pitney Bowes Bank Inc Purchase Power	Paved Streets	Prepaid Postage	40.00	160563	06/02/2023 1
Pitney Bowes Bank Inc Purchase Power	Engineering	Prepaid Postage	220.00	160563	06/02/2023 1
Pitney Bowes Bank Inc Purchase Power	Engineering	Acct# 8000-9090-1129-9471 Postage Purchased	277.20	160563	06/02/2023 1
Pitney Bowes Bank Inc Purchase Power	Economic Development	Prepaid Postage	100.00	160563	06/02/2023 1
Pitney Bowes Bank Inc Purchase Power	Economic Development	Acct# 8000-9090-1129-9471 Postage Purchased	126.00	160563	06/02/2023 1
Pitney Bowes Bank Inc Purchase Power	Airport	Acct# 8000-9090-1129-9471 Postage Purchased	126.00	160563	06/02/2023 1
Pitney Bowes Bank Inc Purchase Power	Airport	Prepaid Postage	100.00	160563	06/02/2023 1
Pitney Bowes Bank Inc Purchase Power	Liquor Store	Prepaid Postage	60.00	160563	06/02/2023 1
Pitney Bowes Bank Inc Purchase Power	Liquor Store	Acct# 8000-9090-1129-9471 Postage Purchased	75.60	160563	06/02/2023 1
		Total for Pitney Bowes Bank Inc Purchase Powe	3,299.60		
<u>Pitney Bowes Global Financial Service</u>					
Pitney Bowes Global Financial Services LLC	Liquor Store	Postage Meter 03/30/23 to 06/29/23 Contract #0040841136	12.34	160764	06/15/2023 1
Pitney Bowes Global Financial Services LLC	Airport	Postage Meter 03/30/23 to 06/29/23 Contract #0040841136	20.57	160764	06/15/2023 1
Pitney Bowes Global Financial Services LLC	Economic Development	Postage Meter 03/30/23 to 06/29/23 Contract #0040841136	20.57	160764	06/15/2023 1
Pitney Bowes Global Financial Services LLC	Engineering	Postage Meter 03/30/23 to 06/29/23 Contract #0040841136	45.26	160764	06/15/2023 1
Pitney Bowes Global Financial Services LLC	Paved Streets	Postage Meter 03/30/23 to 06/29/23 Contract #0040841136	8.23	160764	06/15/2023 1
Pitney Bowes Global Financial Services LLC	Building Inspection	Postage Meter 03/30/23 to 06/29/23 Contract #0040841136	20.57	160764	06/15/2023 1
Pitney Bowes Global Financial Services LLC	Data Processing	Postage Meter 03/30/23 to 06/29/23 Contract #0040841136	12.34	160764	06/15/2023 1
Pitney Bowes Global Financial Services LLC	Parking Lots	Postage Meter 03/30/23 to 06/29/23 Contract #0040841136	12.34	160764	06/15/2023 1

Accounts Payable
Check Approval List - City Council

From: 05/24/2023

To: 06/27/2023



<u>Vendor</u>	<u>Department</u>	<u>Description</u>	<u>Amount</u>	<u>Check Number</u>	<u>Check Date</u>
Pitney Bowes Global Financial Services LLC	Director of Finance	Postage Meter 03/30/23 to 06/29/23 Contract #0040841136	20.57	160764	06/15/2023 1
Pitney Bowes Global Financial Services LLC	Fire Fighting	Postage Meter 03/30/23 to 06/29/23 Contract #0040841136	16.46	160764	06/15/2023 1
Pitney Bowes Global Financial Services LLC	City Manager	Postage Meter 03/30/23 to 06/29/23 Contract #0040841136	20.57	160764	06/15/2023 1
Pitney Bowes Global Financial Services LLC	Parks	Postage Meter 03/30/23 to 06/29/23 Contract #0040841136	16.46	160764	06/15/2023 1
Pitney Bowes Global Financial Services LLC	Planning & Zoning	Postage Meter 03/30/23 to 06/29/23 Contract #0040841136	20.57	160764	06/15/2023 1
Pitney Bowes Global Financial Services LLC	Police Administration	Postage Meter 03/30/23 to 06/29/23 Contract #0040841136	8.23	160764	06/15/2023 1
Pitney Bowes Global Financial Services LLC	Lake Restoration	Postage Meter 03/30/23 to 06/29/23 Contract #0040841136	12.34	160764	06/15/2023 1
Pitney Bowes Global Financial Services LLC	Recording & Reporting	Postage Meter 03/30/23 to 06/29/23 Contract #0040841136	20.57	160764	06/15/2023 1
Pitney Bowes Global Financial Services LLC	Crime Control & Investigation	Postage Meter 03/30/23 to 06/29/23 Contract #0040841136	12.34	160764	06/15/2023 1
Total for Pitney Bowes Global Financial Service			300.33		
Police Dept/ Petty Cash					
Police Dept/ Petty Cash	Crime Control & Investigation	Postage Police Dept	31.90	160487	05/30/2023 1
Total for Police Dept/ Petty Cash			31.90		
Powerplan					
Powerplan	Road & Bridge Equipment	Cutter Tooth, Pock Standard, Straight, Crossover & Belt #168	901.85	160514	06/01/2023 1
Total for Powerplan			901.85		
Prairieland Solid Waste Mgmnt					
Prairieland Solid Waste Mgmnt	Crime Control & Investigation	Shredding Police Dept	40.48	160649	06/09/2023 1
Prairieland Solid Waste Mgmnt	Garbage Collection	Refuse Removal May 2023	875.07	160564	06/02/2023 1
Prairieland Solid Waste Mgmnt	Garbage Collection	May 2023 City Wide Cleanup	3,900.00	160649	06/09/2023 1
Total for Prairieland Solid Waste Mgmnt			4,815.55		
Pritts-Steuber Electric Motors, Inc					
Pritts-Steuber Electric Motors, Inc	Parks	Fan Motor & Blade Park Dept	145.00	160462	05/26/2023 1
Total for Pritts-Steuber Electric Motors, Inc			145.00		
Public Utilities Commission					
Public Utilities Commission	Parks	June 2023 Utilities	438.48	160841	06/21/2023 1
Public Utilities Commission	Parks	June 2023 Utilities	2,806.84	160841	06/21/2023 1
Public Utilities Commission	Parks	June 2023 Utilities	1,238.44	160841	06/21/2023 1
Public Utilities Commission	Parks	June 2023 Utilities	1,104.09	160841	06/21/2023 1
Public Utilities Commission	Parks	June 2023 Utilities 801 E Margaret St	15.83	160841	06/21/2023 1
Public Utilities Commission	Parks	June 2023 Utilities 801 E Margaret St	699.42	160841	06/21/2023 1
Public Utilities Commission	Parks	June 2023 Utilities 801 E Margaret St	68.28	160841	06/21/2023 1
Public Utilities Commission	Street Lighting	June 2023 Utilities	11.82	160841	06/21/2023 1
Public Utilities Commission	Street Lighting	June 2023 Utilities	2,560.05	160841	06/21/2023 1
Public Utilities Commission	Street Lighting	June 2023 Utilities	3,308.66	160841	06/21/2023 1
Public Utilities Commission	Central Garage	June 2023 Utilities	1.87	160841	06/21/2023 1
Public Utilities Commission	Fire Fighting	June 2023 Utilities	21.37	160841	06/21/2023 1
Public Utilities Commission	Central Garage	June 2023 Utilities 801 E Margaret St	227.72	160841	06/21/2023 1
Public Utilities Commission	General Government Buildings	June 2023 Utilities	2,276.43	160841	06/21/2023 1
Public Utilities Commission	General Government Buildings	June 2023 Utilities	101.03	160841	06/21/2023 1
Public Utilities Commission	General Government Buildings	June 2023 Utilities	39.69	160841	06/21/2023 1
Public Utilities Commission	General Government Buildings	June 2023 Utilities	35.62	160841	06/21/2023 1
Public Utilities Commission	Fire Fighting	June 2023 Utilities	62.31	160841	06/21/2023 1

Accounts Payable
Check Approval List - City Council

From: 05/24/2023

To: 06/27/2023



<u>Vendor</u>	<u>Department</u>	<u>Description</u>	<u>Amount</u>	<u>Check Number</u>	<u>Check Date</u>
Public Utilities Commission	Fire Fighting	June 2023 Utilities	359.92	160841	06/21/2023 1
Public Utilities Commission	Fire Fighting	June 2023 Utilities	149.52	160841	06/21/2023 1
Public Utilities Commission	Lake Restoration	June 2023 Utilities	95.45	160841	06/21/2023 1
Public Utilities Commission	SMEC Building	June 2023 Utilities	3,090.77	160841	06/21/2023 1
Public Utilities Commission	SMEC Building	June 2023 Utilities	119.06	160841	06/21/2023 1
Public Utilities Commission	SMEC Building	June 2023 Utilities	39.69	160841	06/21/2023 1
Public Utilities Commission	Aquatic Park	June 2023 Utilities	58.56	160841	06/21/2023 1
Public Utilities Commission	Aquatic Park	June 2023 Utilities	76.90	160841	06/21/2023 1
Public Utilities Commission	Aquatic Park	June 2023 Utilities	183.63	160841	06/21/2023 1
Public Utilities Commission	Aquatic Park	June 2023 Utilities	150.23	160841	06/21/2023 1
Public Utilities Commission	Parks	June 2023 Utilities 801 E Margaret St	159.12	160841	06/21/2023 1
Public Utilities Commission	Paved Streets	June 2023 Utilities	34.98	160841	06/21/2023 1
Public Utilities Commission	Paved Streets	June 2023 Utilities	167.06	160841	06/21/2023 1
Public Utilities Commission	Paved Streets	June 2023 Utilities	28.62	160841	06/21/2023 1
Public Utilities Commission	Paved Streets	June 2023 Utilities	68.57	160841	06/21/2023 1
Public Utilities Commission	Paved Streets	June 2023 Utilities 801 E Margaret St	699.42	160841	06/21/2023 1
Public Utilities Commission	Incubator Building	June 2023 Utilities	90.44	160841	06/21/2023 1
Public Utilities Commission	Incubator Building	June 2023 Utilities	384.85	160841	06/21/2023 1
Public Utilities Commission	Incubator Building	June 2023 Utilities	50.76	160841	06/21/2023 1
Public Utilities Commission	Incubator Building	June 2023 Utilities	21.85	160841	06/21/2023 1
Public Utilities Commission	Liquor Store	June 2023 Utilities	2,027.39	160841	06/21/2023 1
Public Utilities Commission	Airport	June 2023 Utilities	204.90	160841	06/21/2023 1
Public Utilities Commission	Airport	June 2023 Utilities	57.24	160841	06/21/2023 1
Public Utilities Commission	Airport	June 2023 Utilities D Hangar Airport	65.28	160841	06/21/2023 1
Public Utilities Commission	Airport	June 2023 Utilities	627.36	160841	06/21/2023 1
Public Utilities Commission	Airport	June 2023 Utilities	2,229.66	160841	06/21/2023 1
Public Utilities Commission	Liquor Store	June 2023 Utilities	79.37	160841	06/21/2023 1
Public Utilities Commission	Liquor Store	June 2023 Utilities	39.69	160841	06/21/2023 1
Public Utilities Commission	Liquor Store	June 2023 Utilities	55.88	160841	06/21/2023 1
Public Utilities Commission	Library	June 2023 Utilities	39.69	160841	06/21/2023 1
Public Utilities Commission	Library	June 2023 Utilities	92.97	160841	06/21/2023 1
Public Utilities Commission	Library	June 2023 Utilities	750.40	160841	06/21/2023 1
Public Utilities Commission	Library	June 2023 Utilities	21.21	160841	06/21/2023 1
Public Utilities Commission	Parking Lots	June 2023 Utilities	221.94	160841	06/21/2023 1
Public Utilities Commission	Animal Control	June 2023 Utilities	17.41	160841	06/21/2023 1
Public Utilities Commission	Animal Control	June 2023 Utilities	182.20	160841	06/21/2023 1
Public Utilities Commission	Animal Control	June 2023 Utilities	82.62	160841	06/21/2023 1
Public Utilities Commission	Animal Control	June 2023 Utilities	418.49	160841	06/21/2023 1
Public Utilities Commission	Parking Lots	June 2023 Utilities	181.41	160841	06/21/2023 1
Total for Public Utilities Commission			28,442.46		
Recreation Supply Co					
Recreation Supply Co	Aquatic Park	Filter for Handheld Vacuum (H2O Blaster) Aquatic Park	28.00	160842	06/21/2023 1
Recreation Supply Co	Aquatic Park	Acid/Abrasive Wash Brushes Aquatic Park	167.88	160650	06/09/2023 1

Accounts Payable
Check Approval List - City Council

From: 05/24/2023

To: 06/27/2023



<u>Vendor</u>	<u>Department</u>	<u>Description</u>	<u>Amount</u>	<u>Check Number</u>	<u>Check Date</u>
Total for Recreation Supply Co			195.88		
<u>Redi Haul Trailers, Inc</u>					
Redi Haul Trailers, Inc	Road & Bridge Equipment	Tub Panel Bent #105	221.00	160765	06/15/2023 1
Total for Redi Haul Trailers, Inc			221.00		
<u>Reel-A-Pail, Inc</u>					
Reel-A-Pail, Inc	Fire Fighting	225 Foot Cord & Hose Reel	118.68	160463	05/26/2023 1
Total for Reel-A-Pail, Inc			118.68		
<u>Richards Auto Repair</u>					
Richards Auto Repair	Crime Control & Investigation	Tow Hyundai Tucson CFS23-3736 To Impound From BE Ave	395.00	160651	06/09/2023 1
Richards Auto Repair	Crime Control & Investigation	Tow 2021 Ford Explorer to Impound CFS23-3736 from BE Ave	395.00	160651	06/09/2023 1
Richards Auto Repair	Crime Control & Investigation	TOW BMW 535I CFS 23-3599	180.00	160651	06/09/2023 1
Total for Richards Auto Repair			970.00		
<u>Rick Deboer Lettering & Signs</u>					
Rick Deboer Lettering & Signs	Paved Streets	R & R Street # on New City Shop	40.00	160652	06/09/2023 1
Total for Rick Deboer Lettering & Signs			40.00		
<u>River Bend Business Products</u>					
River Bend Business Products	Paved Streets	Office Supplies City Hall	9.90	160766	06/15/2023 1
River Bend Business Products	Engineering	Office Supplies City Hall	54.45	160766	06/15/2023 1
River Bend Business Products	Building Inspection	Office Supplies City Hall	24.75	160766	06/15/2023 1
River Bend Business Products	Data Processing	Office Supplies City Hall	14.85	160766	06/15/2023 1
River Bend Business Products	Liquor Store	Office Supplies City Hall	9.90	160766	06/15/2023 1
River Bend Business Products	Airport	Office Supplies City Hall	24.75	160766	06/15/2023 1
River Bend Business Products	Parking Lots	Office Supplies City Hall	9.90	160766	06/15/2023 1
River Bend Business Products	Crime Control & Investigation	Office Supplies Police Dept	117.96	160464	05/26/2023 1
River Bend Business Products	Crime Control & Investigation	Office Supplies City Hall	14.85	160766	06/15/2023 1
River Bend Business Products	Lake Restoration	Office Supplies City Hall	9.90	160766	06/15/2023 1
River Bend Business Products	SMEC Building	Printer Usage Computer Lab SMEC 04/25 to 05/22/23	0.63	160464	05/26/2023 1
River Bend Business Products	Recording & Reporting	Office Supplies City Hall	24.75	160766	06/15/2023 1
River Bend Business Products	Fire Fighting	Office Supplies City Hall	19.80	160766	06/15/2023 1
River Bend Business Products	Director of Finance	Office Supplies City Hall	24.75	160766	06/15/2023 1
River Bend Business Products	Economic Development	Office Supplies City Hall	14.85	160766	06/15/2023 1
River Bend Business Products	City Manager	Office Supplies City Hall	24.75	160766	06/15/2023 1
River Bend Business Products	Parks	Office Supplies City Hall	19.80	160766	06/15/2023 1
River Bend Business Products	Police Administration	Office Supplies City Hall	9.90	160766	06/15/2023 1
River Bend Business Products	Planning & Zoning	Office Supplies City Hall	24.75	160766	06/15/2023 1
Total for River Bend Business Products			455.19		
<u>RTT Mobile Interpretation</u>					
RTT Mobile Interpretation	Crime Control & Investigation	34 Minutes April 2023, 233 Minutes May 2023	389.82	160653	06/09/2023 1
Total for RTT Mobile Interpretation			389.82		
<u>S W Dust Treatment Inc.</u>					
S W Dust Treatment Inc.	Paved Streets	Dust Treatment	4,947.00	160843	06/21/2023 1
Total for S W Dust Treatment Inc.			4,947.00		
<u>Sandwick</u>					

Accounts Payable
Check Approval List - City Council

From: 05/24/2023

To: 06/27/2023



<u>Vendor</u>	<u>Department</u>	<u>Description</u>	<u>Amount</u>	<u>Check Number</u>	<u>Check Date</u>
Sandwick	Parks	Boiler License	20.00	160767	06/15/2023 1
		Total for Sandwick	20.00		
<u>Shamrock Recycling, Inc.</u>					
Shamrock Recycling, Inc.	Garbage Collection	3 Loads April 2023 Tree Dump Cleanup	1,215.00	160768	06/15/2023 1
		Total for Shamrock Recycling, Inc.	1,215.00		
<u>Sherburn Nursery & Floral LLC</u>					
Sherburn Nursery & Floral LLC	Parks	Flowers & Trees Park Dept	6,570.25	160844	06/21/2023 1
		Total for Sherburn Nursery & Floral LLC	6,570.25		
<u>Smith's Greenhouse</u>					
Smith's Greenhouse	Parks	136 41/2" Potted Plants, 111 3" Potted Plants & 1Pkg Plug Hangin	603.89	160769	06/15/2023 1
		Total for Smith's Greenhouse	603.89		
<u>Southern Glazer's Wine & Spirits of MN</u>					
Southern Glazer's Wine & Spirits of MN	Liquor - Mdse for Resale	Freight	1.55	160855	06/21/2023 1
Southern Glazer's Wine & Spirits of MN	Liquor - Mdse for Resale	Pop/Mix	60.00	160855	06/21/2023 1
Southern Glazer's Wine & Spirits of MN	Liquor - Mdse for Resale	Freight	52.45	160855	06/21/2023 1
Southern Glazer's Wine & Spirits of MN	Liquor - Mdse for Resale	Liquor	3,860.15	160855	06/21/2023 1
Southern Glazer's Wine & Spirits of MN	Liquor - Mdse for Resale	Wine	204.00	160855	06/21/2023 1
Southern Glazer's Wine & Spirits of MN	Liquor - Mdse for Resale	Freight	32.48	160855	06/21/2023 1
Southern Glazer's Wine & Spirits of MN	Liquor - Mdse for Resale	Liquor	2,705.41	160855	06/21/2023 1
Southern Glazer's Wine & Spirits of MN	Liquor - Mdse for Resale	Freight	1.55	160616	06/08/2023 1
Southern Glazer's Wine & Spirits of MN	Liquor - Mdse for Resale	Wine	1,062.73	160616	06/08/2023 1
Southern Glazer's Wine & Spirits of MN	Liquor - Mdse for Resale	Freight	62.00	160616	06/08/2023 1
Southern Glazer's Wine & Spirits of MN	Liquor - Mdse for Resale	Liquor	2,841.44	160616	06/08/2023 1
Southern Glazer's Wine & Spirits of MN	Liquor - Mdse for Resale	Pop/Mix	92.50	160616	06/08/2023 1
Southern Glazer's Wine & Spirits of MN	Liquor - Mdse for Resale	Liquor	1,140.58	160616	06/08/2023 1
Southern Glazer's Wine & Spirits of MN	Liquor - Mdse for Resale	Freight	7.75	160616	06/08/2023 1
Southern Glazer's Wine & Spirits of MN	Liquor - Mdse for Resale	Liquor	8,346.36	160616	06/08/2023 1
Southern Glazer's Wine & Spirits of MN	Liquor - Mdse for Resale	Wine	1,912.00	160616	06/08/2023 1
Southern Glazer's Wine & Spirits of MN	Liquor - Mdse for Resale	Freight	156.28	160616	06/08/2023 1
Southern Glazer's Wine & Spirits of MN	Liquor - Mdse for Resale	Wine	504.12	160616	06/08/2023 1
Southern Glazer's Wine & Spirits of MN	Liquor - Mdse for Resale	Liquor	216.00	160616	06/08/2023 1
Southern Glazer's Wine & Spirits of MN	Liquor - Mdse for Resale	Freight	11.88	160616	06/08/2023 1
Southern Glazer's Wine & Spirits of MN	Liquor - Mdse for Resale	Wine	-6.67	160616	06/08/2023 1
Southern Glazer's Wine & Spirits of MN	Liquor - Mdse for Resale	Liquor	882.68	160616	06/08/2023 1
Southern Glazer's Wine & Spirits of MN	Liquor - Mdse for Resale	Freight	14.21	160616	06/08/2023 1
Southern Glazer's Wine & Spirits of MN	Liquor - Mdse for Resale	Freight	3.10	160855	06/21/2023 1
Southern Glazer's Wine & Spirits of MN	Liquor - Mdse for Resale	Freight	10.85	160616	06/08/2023 1
Southern Glazer's Wine & Spirits of MN	Liquor - Mdse for Resale	Freight	6.20	160616	06/08/2023 1
Southern Glazer's Wine & Spirits of MN	Liquor - Mdse for Resale	Freight	24.80	160616	06/08/2023 1
Southern Glazer's Wine & Spirits of MN	Liquor - Mdse for Resale	Freight	13.95	160855	06/21/2023 1
Southern Glazer's Wine & Spirits of MN	Liquor - Mdse for Resale	Wine	452.20	160855	06/21/2023 1
Southern Glazer's Wine & Spirits of MN	Liquor - Mdse for Resale	Freight	4.65	160855	06/21/2023 1
Southern Glazer's Wine & Spirits of MN	Liquor - Mdse for Resale	Liquor	161.87	160616	06/08/2023 1

Accounts Payable
Check Approval List - City Council

From: 05/24/2023

To: 06/27/2023



<u>Vendor</u>	<u>Department</u>	<u>Description</u>	<u>Amount</u>	<u>Check Number</u>	<u>Check Date</u>
Total for Southern Glazer's Wine & Spirits of MN			24,839.07		
<u>Southern MN Home Creative</u>					
Southern MN Home Creative	Aquatic Park	1/4 vertical page in summer Home Creative Mag	265.00	160515	06/01/2023 1
Total for Southern MN Home Creative			265.00		
<u>Squeegee Brothers</u>					
Squeegee Brothers	General Government Buildings	June 2023 Window Cleaning Out, Upper & Quarterly Inside CH	615.00	160654	06/09/2023 1
Squeegee Brothers	Library	June 2023 Window Cleaning Library	150.00	160654	06/09/2023 1
Squeegee Brothers	Airport	Window Cleaning Out & Entry & Quarterly Inside Airport	155.00	160770	06/15/2023 1
Total for Squeegee Brothers			920.00		
<u>Stevens</u>					
Stevens	Crime Control & Investigation	EVOC/PIT St Cloud, MN 05/23 to 05/25/2023	312.74	0	06/01/2023 1
Total for Stevens			312.74		
<u>Streicher's</u>					
Streicher's	Crime Control & Investigation	Uniforms New Hire Cromwell	1,149.83	160655	06/09/2023 1
Streicher's	Crime Control & Investigation	Uniforms New Hire Slater	1,075.83	160655	06/09/2023 1
Total for Streicher's			2,225.66		
<u>Superior Vision Insurance Inc NGLIC</u>					
Superior Vision Insurance Inc NGLIC	Health Insurance	June 2023 Vision Insurance Premiums	475.15	160488	05/30/2023 1
Total for Superior Vision Insurance Inc NGLIC			475.15		
<u>Taft Stettinius & Hollister LLP</u>					
Taft Stettinius & Hollister LLP	Other General Gov't	Community Center Financing	10,000.00	160656	06/09/2023 1
Total for Taft Stettinius & Hollister LLP			10,000.00		
<u>Tallgrass Cider</u>					
Tallgrass Cider	Liquor - Mdse for Resale	Beer	205.00	160617	06/08/2023 1
Total for Tallgrass Cider			205.00		
<u>Talos Dynamics</u>					
Talos Dynamics	Crime Control & Investigation	Replacement Body Armor & Carrier Schwebke	1,657.56	160657	06/09/2023 1
Talos Dynamics	Crime Control & Investigation	Replacement Body Armor & Carrier Bass	1,657.56	160657	06/09/2023 1
Talos Dynamics	Crime Control & Investigation	Replacement Body Armor & Carrier Asmus	1,657.56	160657	06/09/2023 1
Total for Talos Dynamics			4,972.68		
<u>Team Laboratory Chemical, LLC</u>					
Team Laboratory Chemical, LLC	Parks	Wipe Out Gran Herb, Terra Plus Herbicide, Shoreklear Plus	2,101.00	160465	05/26/2023 1
Total for Team Laboratory Chemical, LLC			2,101.00		
<u>Teigland</u>					
Teigland	Aquatic Park Charges	Swimming Lessons Refund	45.00	160466	05/26/2023 1
Total for Teigland			45.00		
<u>Thimesch</u>					
Thimesch	Non-departmental	Refund Check 018467-000, 104 1/2 E 5th #4	0.84	160590	06/02/2023 1
Thimesch	Non-departmental	Refund Check 018467-000, 104 1/2 E 5th #4	0.33	160590	06/02/2023 1
Thimesch	Non-departmental	Refund Check 018467-000, 104 1/2 E 5th #4	0.19	160590	06/02/2023 1
Thimesch	Non-departmental	Refund Check 018467-000, 104 1/2 E 5th #4	0.32	160590	06/02/2023 1
Total for Thimesch			1.68		
<u>Tonneson</u>					

Accounts Payable
Check Approval List - City Council



From: 05/24/2023

To: 06/27/2023

<u>Vendor</u>	<u>Department</u>	<u>Description</u>	<u>Amount</u>	<u>Check Number</u>	<u>Check Date</u>
Tonneson	Building Inspection	May 2022 Building Official Services (05/24 & 05/31/2023)	960.00	0	06/09/2023 1
Tonneson	Building Inspection	May 2022 Building Official Services 05/02 to 05/23/2023	4,800.00	0	06/09/2023 1
Total for Tonneson			5,760.00		
<u>Tow Distributing</u>					
Tow Distributing	Liquor - Mdse for Resale	Liquor	1,618.60	160856	06/21/2023 1
Tow Distributing	Liquor - Mdse for Resale	Beer	35,112.45	160856	06/21/2023 1
Tow Distributing	Liquor - Mdse for Resale	Pop/Mix	275.00	160856	06/21/2023 1
Tow Distributing	Liquor - Mdse for Resale	Liquor	1,247.14	160618	06/08/2023 1
Tow Distributing	Liquor - Mdse for Resale	Pop/Mix	253.00	160618	06/08/2023 1
Tow Distributing	Liquor - Mdse for Resale	Beer	48,233.09	160618	06/08/2023 1
Total for Tow Distributing			86,739.28		
<u>Trailer Delivery Service</u>					
Trailer Delivery Service	Paved Streets	Delivery of Street Dept Trailer	900.00	160565	06/02/2023 1
Total for Trailer Delivery Service			900.00		
<u>Truck Center Companies East LLC</u>					
Truck Center Companies East LLC	Road & Bridge Equipment	Automatic Slack Adjuster Street #113	63.96	160489	05/30/2023 1
Truck Center Companies East LLC	Road & Bridge Equipment	Applied to XA303146882:01	-9.02	160658	06/09/2023 1
Truck Center Companies East LLC	Road & Bridge Equipment	Clamp-Band 4in Street #113	35.76	160658	06/09/2023 1
Truck Center Companies East LLC	Road & Bridge Equipment	Air Filter	165.07	160771	06/15/2023 1
Truck Center Companies East LLC	Road & Bridge Equipment	Rear Leaf Spring Assembly, Pins, UBolts Street #113	1,252.64	160516	06/01/2023 1
Truck Center Companies East LLC	Road & Bridge Equipment	U Bolt Kit RND 7/8 in x 3in x1 #113	-128.34	160658	06/09/2023 1
Truck Center Companies East LLC	Road & Bridge Equipment	Muffler, Stack, Tail Spout Street #113	655.09	160516	06/01/2023 1
Truck Center Companies East LLC	Road & Bridge Equipment	U Bolt Kit 7/8 x 3in x 20-1/ Street #113	85.03	160658	06/09/2023 1
Truck Center Companies East LLC	Road & Bridge Equipment	Stack #113	-62.51	160658	06/09/2023 1
Truck Center Companies East LLC	Road & Bridge Equipment	U Bolt Kit 7/8in x 3 x 20-1	95.03	160658	06/09/2023 1
Truck Center Companies East LLC	Road & Bridge Equipment	Slack Adjuster Street #113	102.56	160489	05/30/2023 1
Truck Center Companies East LLC	Road & Bridge Equipment	Applied to XA303146882:01	-54.34	160658	06/09/2023 1
Truck Center Companies East LLC	Road & Bridge Equipment	Tail Spout #113	57.70	160658	06/09/2023 1
Truck Center Companies East LLC	Road & Bridge Equipment	Gasket Axle Street #113	4.85	160516	06/01/2023 1
Truck Center Companies East LLC	Road & Bridge Equipment	Diagnose & Report Fault Code #115	645.15	160658	06/09/2023 1
Truck Center Companies East LLC	Road & Bridge Equipment	Fuel Filter, Filter	368.82	160658	06/09/2023 1
Truck Center Companies East LLC	Road & Bridge Equipment	Automatic Slack Adjuster Street #113	-63.96	160489	05/30/2023 1
Truck Center Companies East LLC	Central Garage	Flammable Bule Cemnet	8.68	160516	06/01/2023 1
Truck Center Companies East LLC	Central Garage	Tite-Seal Doc Holder	17.52	160516	06/01/2023 1
Truck Center Companies East LLC	Central Garage	Tire Patches	97.93	160516	06/01/2023 1
Truck Center Companies East LLC	Central Garage	Tite-Seal Doc Holder, Document Holder	29.67	160516	06/01/2023 1
Total for Truck Center Companies East LLC			3,367.29		
<u>ULINE</u>					
ULINE	Parks	Shelves Park Dept	122.34	160659	06/09/2023 1
Total for ULINE			122.34		
<u>USA Blue Book</u>					
USA Blue Book	Paved Streets	Female Coupler, Male Hose X Hose Band Street	96.11	160845	06/21/2023 1
Total for USA Blue Book			96.11		

Accounts Payable
Check Approval List - City Council

From: 05/24/2023

To: 06/27/2023



<u>Vendor</u>	<u>Department</u>	<u>Description</u>	<u>Amount</u>	<u>Check Number</u>	<u>Check Date</u>
<u>Verizon Wireless</u>					
Verizon Wireless	Engineering	Cell Phone 4/21/23 to 05/20/2023 Engineering Dept	180.94	160566	06/02/2023 1
Verizon Wireless	Building Inspection	Cell Phone 4/21/23 to 05/20/2023 Bldg Inspector	46.11	160566	06/02/2023 1
Verizon Wireless	Data Processing	04/24 to 05/23/2023 Backup Router	10.02	160566	06/02/2023 1
Verizon Wireless	Paved Streets	Cell Phone 4/21/23 to 05/20/2023 Street Dept	46.11	160566	06/02/2023 1
Verizon Wireless	Airport	Cell Phone 4/21/23 to 05/20/2023 Airport	46.11	160566	06/02/2023 1
Verizon Wireless	Parks	Cell Phone 4/21/23 to 05/20/2023 Park Dept	92.22	160566	06/02/2023 1
Verizon Wireless	Aquatic Park	Cell Phone 4/21/23 to 05/20/2023 Aquatic Park	46.11	160566	06/02/2023 1
Verizon Wireless	Crime Control & Investigation	Cell Phone 4/21/23 to 05/20/2023 Police Dept	1,338.16	160566	06/02/2023 1
Verizon Wireless	City Manager	Cell Phone 4/21/23 to 05/20/2023 City Admin	46.11	160566	06/02/2023 1
Verizon Wireless	Director of Finance	Cell Phone 4/21/23 to 05/20/2023 Finance Dept	46.11	160566	06/02/2023 1
Verizon Wireless	Planning & Zoning	Cell Phone 4/21/23 to 05/20/2023 Planning & Zoning	46.11	160566	06/02/2023 1
		Total for Verizon Wireless	1,944.11		
<u>Verizon Wireless-VSAT</u>					
Verizon Wireless-VSAT	Crime Control & Investigation	SMS Content 05/14/23 to 05/17/2023	50.00	160467	05/26/2023 1
		Total for Verizon Wireless-VSAT	50.00		
<u>Vicente</u>					
Vicente	Non-departmental	Refund Check 017435-001, 1013 N NORTH AVE	0.14	160591	06/02/2023 1
Vicente	Non-departmental	Refund Check 017435-001, 1013 N NORTH AVE	0.13	160591	06/02/2023 1
Vicente	Non-departmental	Refund Check 017435-001, 1013 N NORTH AVE	0.37	160591	06/02/2023 1
Vicente	Non-departmental	Refund Check 017435-001, 1013 N NORTH AVE	0.01	160591	06/02/2023 1
Vicente	Non-departmental	Refund Check 017435-001, 1013 N NORTH AVE	0.09	160591	06/02/2023 1
		Total for Vicente	0.74		
<u>Vinnies Minn Snow</u>					
Vinnies Minn Snow	Aquatic Park	Food for Resale Aquatic Park	325.85	160772	06/15/2023 1
Vinnies Minn Snow	Aquatic Park	Food for Resale Aquatic Park	487.30	160846	06/21/2023 1
Vinnies Minn Snow	Aquatic Park	Food for Resale Aquatic Park	554.80	160567	06/02/2023 1
		Total for Vinnies Minn Snow	1,367.95		
<u>Vinocopia, Inc</u>					
Vinocopia, Inc	Liquor - Mdse for Resale	Freight	21.00	160857	06/21/2023 1
Vinocopia, Inc	Liquor - Mdse for Resale	Liquor	180.00	160857	06/21/2023 1
Vinocopia, Inc	Liquor - Mdse for Resale	Pop/Mix	120.00	160857	06/21/2023 1
Vinocopia, Inc	Liquor - Mdse for Resale	Wine	744.00	160857	06/21/2023 1
		Total for Vinocopia, Inc	1,065.00		
<u>Visit Fairmont</u>					
Visit Fairmont	CVB	Hotel/Motel Tax April 2023 due in May 2023 \$11,789.21 Less 5%	11,199.75	160568	06/02/2023 1
		Total for Visit Fairmont	11,199.75		
<u>Voss Cleaning Services, Inc.</u>					
Voss Cleaning Services, Inc.	Library	May 2023 Janitorial Service Library	925.00	160660	06/09/2023 1
Voss Cleaning Services, Inc.	Airport	June 2023 Janitorial & Rug Service Airport	316.00	160773	06/15/2023 1
Voss Cleaning Services, Inc.	Incubator Building	June 2023 Rug & Janitorial Service Incubator	137.00	160660	06/09/2023 1
Voss Cleaning Services, Inc.	Paved Streets	Vacuum With Attachments For Parks & Street Dept	214.50	160717	06/09/2023 1
Voss Cleaning Services, Inc.	Paved Streets	June 2023 Janitorial & Rug Service Street/Park Dept	247.50	160660	06/09/2023 1

Accounts Payable
Check Approval List - City Council



From: 05/24/2023

To: 06/27/2023

<u>Vendor</u>	<u>Department</u>	<u>Description</u>	<u>Amount</u>	<u>Check Number</u>	<u>Check Date</u>
Voss Cleaning Services, Inc.	SMEC Building	June 2023 Janitorial Service SMEC	992.00	160660	06/09/2023 1
Voss Cleaning Services, Inc.	Parks	Vacuum With Attachments For Parks & Street Dept	214.50	160717	06/09/2023 1
Voss Cleaning Services, Inc.	Parks	June 2023 Janitorial & Rug Service Street/Park Dept	247.50	160660	06/09/2023 1
Voss Cleaning Services, Inc.	General Government Buildings	June 2023 Janitorial & Rug Service City Hall	814.00	160660	06/09/2023 1
Voss Cleaning Services, Inc.	Fire Fighting	June 2023 Janitorial Services Fire Dept	389.00	160660	06/09/2023 1
		Total for Voss Cleaning Services, Inc.	4,497.00		
<u>Waste Management Of So MN</u>					
Waste Management Of So MN	Incubator Building	Refuse Removal May 2023 Incubator	427.44	160661	06/09/2023 1
		Total for Waste Management Of So MN	427.44		
<u>Webber Recreational Design, Inc.</u>					
Webber Recreational Design, Inc.	Parks	2 Post Hip 22x14x10' Shade Structure	26,100.00	160517	06/01/2023 1
		Total for Webber Recreational Design, Inc.	26,100.00		
<u>Wex Health, Inc.</u>					
Wex Health, Inc.	Health Insurance	May 2023 Admin Fees	170.50	0	06/12/2023 1
		Total for Wex Health, Inc.	170.50		
<u>Wine Merchants</u>					
Wine Merchants	Liquor - Mdse for Resale	Freight	2.15	160619	06/08/2023 1
Wine Merchants	Liquor - Mdse for Resale	Freight	3.96	160619	06/08/2023 1
Wine Merchants	Liquor - Mdse for Resale	Wine	206.85	160619	06/08/2023 1
Wine Merchants	Liquor - Mdse for Resale	Wine	254.00	160619	06/08/2023 1
Wine Merchants	Liquor - Mdse for Resale	Freight	1.98	160858	06/21/2023 1
Wine Merchants	Liquor - Mdse for Resale	Wine	96.00	160858	06/21/2023 1
		Total for Wine Merchants	564.94		
<u>Wold Architects & Engineers</u>					
Wold Architects & Engineers	Parks	Sylvania Band Shell Improvements May 2023	1,921.48	160662	06/09/2023 1
Wold Architects & Engineers	General Government Buildings	Facility Assessments Billed to Date 100% of Study	469.31	160468	05/26/2023 1
		Total for Wold Architects & Engineers	2,390.79		
<u>Wood</u>					
Wood	Non-departmental	Refund Check 018516-000, 216 E 3rd St E Apt	0.57	160592	06/02/2023 1
Wood	Non-departmental	Refund Check 018516-000, 216 E 3rd St E Apt	0.08	160592	06/02/2023 1
Wood	Non-departmental	Refund Check 018516-000, 216 E 3rd St E Apt	0.81	160592	06/02/2023 1
Wood	Non-departmental	Refund Check 018516-000, 216 E 3rd St E Apt	0.81	160592	06/02/2023 1
		Total for Wood	2.27		
<u>Yeager Implement, Inc.</u>					
Yeager Implement, Inc.	Road & Bridge Equipment	Latch #823	245.16	160847	06/21/2023 1
Yeager Implement, Inc.	Parks	Bush Hog Blades Soccer Mower	189.98	160774	06/15/2023 1
Yeager Implement, Inc.	Parks	Drive Belt #814	104.09	160774	06/15/2023 1
Yeager Implement, Inc.	Parks	Limit Spac (3) #814	123.51	160774	06/15/2023 1
		Total for Yeager Implement, Inc.	662.74		
<u>Zamora</u>					
Zamora	Non-departmental	Refund Check 018194-000, 924 N PRAIRIE AVE	0.48	160593	06/02/2023 1
Zamora	Non-departmental	Refund Check 018194-000, 924 N PRAIRIE AVE	0.48	160593	06/02/2023 1
Zamora	Non-departmental	Refund Check 018194-000, 924 N PRAIRIE AVE	0.04	160593	06/02/2023 1

Accounts Payable
Check Approval List - City Council

From: 05/24/2023

To: 06/27/2023



<u>Vendor</u>	<u>Department</u>	<u>Description</u>	<u>Amount</u>	<u>Check Number</u>	<u>Check Date</u>
Zamora	Non-departmental	Refund Check 018194-000, 924 N PRAIRIE AVE	1.26	160593	06/02/2023 1
Zamora	Non-departmental	Refund Check 018194-000, 924 N PRAIRIE AVE	0.32	160593	06/02/2023 1
Total for Zamora			2.58		
Ziemer					
Ziemer	Non-departmental	Refund Check 018410-000, 620 Summit Dr #211	2.22	160595	06/02/2023 1
Ziemer	Non-departmental	Refund Check 018410-000, 620 Summit Dr #211	3.33	160595	06/02/2023 1
Ziemer	Non-departmental	Refund Check 018410-000, 620 Summit Dr #211	0.31	160595	06/02/2023 1
Ziemer	Non-departmental	Refund Check 018410-000, 620 Summit Dr #211	3.33	160595	06/02/2023 1
Total for Ziemer			9.19		
			807,706.89		